

SECTION

2

TOOLS AND
MACHINERY OF
AGRICULTURE



MODERN TECHNICAL AND MECHANISED AGRICULTURE

Modern Technical Agriculture

INTRODUCTION

In this section, we will discuss measuring tools in agriculture which encompass a wide range of instruments used to quantify various aspects of farming operations. They play a vital role in optimising agricultural practices, enhancing productivity and ensuring sustainable farming methods. These tools include devices for measuring soil pH, moisture content, temperature, and crop growth.

Indigenous and standard units of measurement in agriculture are crucial for effective communication and sustainable practices. Understanding local measurements, rooted in indigenous knowledge alongside standardised metrics ensures precision in crop yield, land area and resource management. By bridging traditional wisdom with modern methodologies, farmers can optimise productivity while preserving cultural heritage and ecological balance.

We will also delve into farm mechanisation and power and their importance in agricultural production. You will learn the meaning and importance of farm mechanisation and power, and their applications in agricultural production. The lesson will also look at the various activities in agricultural production that farm machinery and power are applied, such as land preparation, planting, cultivation, irrigation, pest control, harvesting and post-harvest handling. This section also looks at the sources of farm power for sustainable agricultural production. In the quest to use farm machinery and power, there is the need to ensure safety precautions to prevent accidents and injuries on the farm site. The lesson will also equip you with the skills and principles related to the operations of various agricultural machinery and how to optimise their usage for improved efficiency and sustainability.

At the end of this section, you should be able to:

- Outline the uses and maintenance procedures for measuring tools used in agricultural production.
- Relate the indigenous measuring tools to the standardised units of measurements in agricultural production.
- Demonstrate the use of simple scientific measuring tools to calculate parameters related to the various agricultural sectors.

- Explain the meaning and importance of farm mechanisation and power in agricultural production.
- Describe the safety measures employed in operating farm machines and power in agricultural production.
- Apply the knowledge and skills of safety measures in handling accidents and injuries of an agricultural worker using appropriate first aid.
- Describe the types and uses of farm machines and power in agricultural production.
- Describe the factors that affect the use of farm machines and power.
- Identify the principal parts of farm machines and implements and state their functions.
- Operate and maintain farm machines and implements in agricultural production.

Key Ideas

- Farm mechanisation is the use of farm machinery, tools and equipment to help or partially replace the human source of power on the farm.
- Farm power is the energy, force and source used to carry out farming operations.
- Safety measures are protocols, activities and precautions taken to improve safety.
- Measuring tools are tools that are used to measure a physical quantity. They must be kept well to be used for a long time.
- Indigenous measuring is the traditional/local way of measuring or quantifying objects in our various communities.
- Standard units of measurement are the measurements which are accepted and understood by the whole world.

MEASURING TOOLS IN AGRICULTURE, THEIR USES AND MAINTENANCE

What are Measuring Tools?

They are devices or instruments used to quantify and determine various physical quantities such as length, width, volume, weight, temperature and time accurately.

Examples of Measuring Tools in Agriculture, Their Uses and Maintenance.

Soil pH meter: This is the instrument used to measure the acidity and alkalinity of the soil, which is important for determining the appropriate soil conditions for different crops. It can be maintained by cleaning the dirt after use, keeping it in a cool dry place and handling with care.

Thermometer: This is used to measure temperature (that is hotness and coldness) of the soil or animals. It can be maintained by cleaning the dirt after use, keeping them in a cool dry place, avoid exposing them to extreme temperatures and keeping them their protective case after use.

Rain gauge: It is used to measure the amount of rainfall, which is important for irrigation planning and water resource management. It can be maintained by cleaning the dirt after use, keeping it in a cool dry place, and avoid exposing them to extreme temperatures. This will ensure measurement accuracy.

Weighing scale: This is used to measure the weight of agricultural produce such as feed, harvested crops, meat from livestock, fertilisers, etc. It can be maintained by cleaning off the soil or other foreign materials after use and putting them back in their protective case.

Anemometer: An anemometer is used to measure wind speed and direction. These help farmers to know the wind pattern that affect plant growth, when and how to apply chemicals and also help in building shelter and protection for farm animals. This tool can be maintained by avoiding exposing it to harsh chemicals, cleaning it regularly to remove dirt and dust, follow the manufacturer's guidelines for usage and checking the calibration periodically to ensure accurate measurement.

Grain moisture meter: It measures the moisture content in grains, ensuring proper storage conditions and preventing spoilage. Clean after each use and calibrate according to the manufacturer's instructions. Avoid exposing them to extreme temperatures and excessive force.

Tension meter: It measures soil moisture tension. It assists in irrigation management. Clean off the soil after use and store in a cool dry place.

Light meter: It measures light intensity, helping farmers assess plant growth and optimise crop placement. Clean after use and store in a protective case.

Length measuring tools: These are tools that are used to measure the height or length of plants. Some of the tools are tapes, rulers or laser rangefinders. Avoid exposing them to extreme temperatures, avoid throwing them around to prevent breakage, clean off the soil after use and store them in a cool dry place.

Chlorophyll meter: Measures the chlorophyll (green pigment found in leaves, which help in photosynthetic activities) content in plant leaves for nutrient management and stress detection. Clean after use and store in a protective case.

Drenching gun: It is used to measure and administer oral medication, such as dewormers and other liquids, to livestock. It allows farmers and veterinarians to deliver the required dosage directly into the animals' mouth. Clean after each use, regular inspection of the gun, store in a dry and clean place to prevent rust.

Leaf area meter: This is used to measure the total leaf surface area of plants. It can be maintained by cleaning off after use, avoid exposure to extreme temperatures and harsh chemicals and put them back in their protective case after use.

Vernier calliper: A Vernier caliper is a precision measuring instrument that can be used for length (outer diameter, inner diameter, or thickness of seeds, stems, pipes, or machine parts), depth (depth of holes, trenches, or any other recessed areas in agricultural equipment or structures), and step (height or steps of objects, which can be useful for assessing irregular surfaces or determining height differences) measurements. Vernier callipers require lubrication to maintain smooth movement and prevent friction. Apply a small amount of a suitable lubricant according to the manufacturer's recommendations.

Nitrate test strips: They are used to measure or assess the nitrate levels in soil or plant tissues. Store in a cool dry place, follow manufacturer's instructions and keep away from contaminants.



Figure 2.1 Examples of agricultural measuring tools

Activity 2.1

Go through the following activities to prepare a picture album of measuring tools used in your community, their uses and how they are maintained;

- a. Visit some farmers or gardeners in your community,

- b. Identify some of the agricultural measuring tools used on the farm
- c. Take pictures of the measuring tools.
- d. Enquire and write down the name of each tool.
- e. Describe the type of farm and agricultural work it is typically used for.
- f. Write down how the tools are maintained
- g. Make a presentation in class for inputs.

Activity 2.2

1. Under the guidance of a technician or instructor, use the provided measuring tools to perform the indicated laboratory and field measurements below.
2. Record your observations and measurements accurately in the spaces provided below.
3. Share your findings and observations with your peers after completing the exercise.

Laboratory Measurements

1. **Tool:** Vernier Calliper

Task: Measure the thickness of a metal plate provided and record the measured thickness in millimetres (mm). Thickness of metal plate: _____ mm

2. **Tool:** Graduated Cylinder

Task: Measure the volume of water in the graduated cylinder and record the measured volume in millilitres (ml). Volume of Water: _____ ml

Field Measurements

1. **Tool:** Tape Measure

Task: Measure the length of a designated area in the field and record the measured length in metres (m). Length of designated area: _____ m

2. **Tool:** Anemometer

Task: Measure the wind speed at the designated location in the field and record the measured wind speed in kilometres per hour (km/h). Wind Speed: _____ km/h

Caution: Ensure safety precautions are followed while handling and using the measuring tools.

INDIGENOUS MEASURING TOOLS AND STANDARD UNITS OF MEASUREMENT IN AGRICULTURAL PRODUCTION

Meaning of Indigenous Measuring Tools

They are tools which are developed using available resources and traditional knowledge for measuring. Examples of such tools are ‘olonka’, hand span, ‘milk tin’, buckets, ‘paint rubber’, calabash, etc.

Examples of Indigenous Measuring Tools

The following are examples of indigenous measuring tools:

Hand span: This is an indigenous method of estimating the width or length of an area or object. It is measured from the tip of the thumb to the tip of the little finger. In agriculture, farmers used this method to measure the spacing between crop rows, the distance between plants during transplantation or the length of certain agriculture tools.

‘Bolga basket’: Bolga baskets are a type of handcrafted artisan basket originating from the Upper East Region. They are used for measuring grain or other farm produce. Farmers or market women fill it with farm produce such as maize, beans or millet to estimate the price to consumers or buyers.

Calabash: This is one of the indigenous measuring tools for liquid substances. Many farmers use the hollowed-out shell to estimate quantities of local beverages such as Pito, Palm wine or alcohol, Sobolo, etc. Others use a calabash to measure grains or seeds.

‘Olonka’ or paint containers: This is a traditional measuring container obtained from a standard-sized used paint container or similar container. It is commonly used to determine the price of food commodities like gari (processed cassava granules), flour, kokonte flour, corn dough, maize, beans, millet, etc.

‘Tin’ containers or Cans: Tin containers, often repurposed cans or containers from canned products, are used to measure smaller quantities of agricultural commodities. In the market, they are used to measure powdered pepper, gari, rice, flour and other powdered substances. Farmers also use them to measure the quantity of seeds or grains to be sown.

‘Gyynam’ stick: This is a locally made stick made from a long, straight stem of a specific tree or plant. It is normally used to estimate the height of crops during different growth stages and also for measuring planting distance in plantations like cocoa, cashew and rubber.

Balance: This is made from strong trees and woven baskets. It is an instrument used for comparing the weights of two bodies, usually for scientific purposes, to determine

the difference in weight. Farmers used this to measure produce such as palm fruit and rubber in the farm.

Sack: A sack is a large bag made of strong cloth, paper, or plastic. It is commonly used to store and carry large amounts of produce. Most farmers use sacks to measure grains such as maize, cowpea, millet, and sometimes, tubers and vegetables.



Fig 2.2 Types of indigenous Agricultural measuring tools Sack

Standard Units of Measurement in Agriculture Production

Meaning of standard unit of measurement in agricultural production

A standard unit of measurement is a globally accepted method of measuring quantities. It ensures consistency and accuracy in measurements across the world. They are fixed and universally accepted values used to determine quantities. They provide uniformity in measurement.

These units are convenient for everyone to use, regardless of their location or field of study. For example, a sack of cocoa that weighs 50kg in Ghana will weigh 50kg when sent to China.



Fig 2.3 Examples of instruments for measuring standard units

Standard unit of measurement and their instruments

Quantity	Measuring instrument	Unit
Mass	Balances and electronic balances	Kilogram (kg) Grams (g)
Length	Metre rule, surveyors' tape, vernier callipers	Metre (m), centimetres(cm), millimetres(mm)
Amount of substance	Mole meter	Mole (mol)
Time	Stop clocks and watches	Seconds(s)
Temperature	Thermometer	Kelvin(K) or Degrees Celsius($^{\circ}$ C)
Luminous intensity	Photometer	Candela(cd)
Electric current	Ammeter	Ampere (A)

Activity 2.3

Visit your community market and find out the indigenous tools used by the market traders and farmers for measuring agricultural produce.

1. Make a picture album of the indigenous measuring tools and present it to the class.

2. Complete the table for ten (10) indigenous tools used for measuring in the market in a table below.

	Indigenous Tool Name	What is Used to Measure	Drawing of Tool Or Photo
1			
2			
3			
4			
5			
6			
7			
8			
9			
10			

Activity 2.4

1. Get at least 3 indigenous measuring tools used in your community.
2. Use them to measure a quantity of an agricultural product (for example Olonka to measure maize) and convert the quantity to a standard unit (like kg) by measuring the same quantity with a standardised measuring tool.
3. Prepare a table showing the equivalent values of indigenous measurement units and their corresponding standardised units.

Indigenous Measurement Units Vs. Standardised Units Conversion Table

Indigenous tool	Indigenous Measurement Unit	Standardised Unit
[Indigenous Tool 1]	[Indigenous Unit 1]	[Standardised Unit 1]
[Indigenous Tool 2]	[Indigenous Unit 2]	[Standardised Unit 2]
[Indigenous Tool 3]	[Indigenous Unit 3]	[Standardised Unit 3]
[Indigenous Tool 4]	[Indigenous Unit 4]	[Standardised Unit 4]
[Indigenous Tool 5]	[Indigenous Unit 5]	[Standardised Unit 5]
[Indigenous Tool 6]	[Indigenous Unit 6]	[Standardised Unit 6]
[Indigenous Tool 7]	[Indigenous Unit 7]	[Standardised Unit 7]
[Indigenous Tool 8]	[Indigenous Unit 8]	[Standardised Unit 8]
[Indigenous Tool 9]	[Indigenous Unit 9]	[Standardised Unit 9]
[Indigenous Tool 10]	[Indigenous Unit 10]	[Standardised Unit 10]

Instructions for completing the table;

- a. In the ‘Indigenous Tool’ column, write down the name of the indigenous tool you are identifying.
 - b. In the ‘Indigenous Measurement Unit’ column, write down the names or symbols of the indigenous measurement units you want to convert.
 - c. In the ‘Standardised Unit’ column, write down the corresponding standardised units to which you want to convert the indigenous units.
 - d. Fill in the table with the equivalent values of each indigenous unit in the standardised unit section.
 - e. Use additional rows if needed to include more measurement units.
4. Discuss your findings and observations with your peers or teacher.

Activity 2.6

1. Using the guided questions below, discuss with your peer, the implications of using indigenous measuring tools in agricultural production.
 - a. How do indigenous measuring tools reflect the cultural and historical significance of agriculture in your community?

- b. What are the advantages and limitations of using indigenous measuring tools in agricultural practices?
 - c. How do indigenous measuring tools contribute to local knowledge systems and sustainable farming practices?
 - d. What role do indigenous measuring tools play in preserving traditional farming techniques and indigenous knowledge?
 - e. How can the integration of indigenous measuring tools with modern agricultural practices enhance productivity and efficiency?
 - f. What challenges or barriers exist in the widespread adoption and acceptance of indigenous measuring tools in agricultural activities?
2. Share your ideas with your class for input.

BASIC PARAMETERS AND THEIR CALCULATIONS IN AGRICULTURAL PRODUCTION

A parameter is any characteristic that helps define or classify a particular system, event, project, object or situation. It plays a major role in agriculture by helping farmers to identify a system or evaluate its performance, status and conditions.

Examples of Basic Parameters Measured in Agricultural Production and Their Calculation

Hen day egg production: It refers to the number of eggs produced by a group of hens in one day, typically standardised to the number of hens present.

$$\text{Hen day egg production} = \frac{\text{Number of eggs produced in a day} \times 100}{\text{Total Number of hens (layers)}}$$

Feed conversion efficiency (FCE): Is a measure used in animal agriculture, including poultry farming, to evaluate how efficiently animals convert feed into desired outputs, such as meat, eggs, or milk.

$$\text{Feed conversion efficiency} = \frac{\text{Amount of Feed Consumed}}{\text{Weight Gained}}$$

Area of a vegetable bed: It measures the length and width (breadth) of the vegetable bed using a measuring tape or distance measuring wheel. It is measured in m².

$$\text{Area} = \text{length} \times \text{width}.$$

Plant population density: This is used to determine the success of planting a crop by calculating potential yield.

$$\text{Plant population density} = \frac{\text{Area of land (m}^2\text{)} \times \text{Number of plants per stand}}{\text{Plant spacing within the row (m)} \times \text{row spacing (m)}}$$

Mortality rate: It is also called the 'death rate'. It is used to determine the total number of deaths within a specific period.

$$\text{Mortality Rate} = \frac{\text{Number of Death} \times 100}{\text{Total Population}}$$

Dosage of veterinary drugs: The dosage of veterinary drugs refers to the specific amount of medication or substance prescribed for an animal based on factors such as its species, size, age, health condition and the intended therapeutic effect. Determining the correct dosage is crucial to ensure the effectiveness of treatment while minimising the risk of adverse effects or toxicity. Consult the drug's label or package insert for recommended dosage guidelines.

Temperature: This is the degree of hotness or coldness of a body. This can be measured using a thermometer. Place the thermometer in the appropriate location (e.g. rectum or mouth) and wait for the reading to stabilise to measure body temperature accurately.

Humidity: This refers to the amount of water vapour present in the air. A hygrometer or digital humidity meter is the device used to measure humidity. Place the device in the desired area or environment to obtain the humidity reading.

Soil acidity or Alkalinity: The concentration of hydrogen ions in the soil can be determined using the soil pH meter. A soil sample is mixed with distilled water and the pH electrodes of the meter are inserted in the mixture. The pH reading stabilises after a short period of time.

Stocking rate: This is a measure used in agriculture to determine the number of fish that can be supported in a particular area of water over a specific period. It takes into account factors such as the size and depth of the area, the nutritional needs of the fish, and the sustainability of the land.

$$\text{Stocking Rate} = \frac{\text{Total number of fish} \times 100}{\text{Area of water body}}$$

Dressing percentage of carcass: Dressing percentage is a measurement of the weight of the carcass compared to the live weight of the animal. It is calculated by dividing the carcass weight by the live weight of the animal and expressing the result as a percentage.

$$\text{Dressing percentage} = \frac{\text{Weight of dressed carcass} \times 100}{\text{Live weight of animal}}$$

Germination percentage: This measures the viability and quality of seeds. It indicates the proportion of seeds that successfully sprout and develop into seedlings under specific conditions within a given period.

$$\text{Germination percentage} = \frac{\text{Number of germinated seed} \times 100}{\text{Number of seeds planted}}$$

Seed rate: This determines the number of seed required for a unit area of land to grow a crop successfully. It is determined by factors such as crop variety, seed size, planting method, spacing, soil type, climate, pest and disease incidence.

$$\text{Seed rate} = \frac{\text{Plant population density} \times 100}{\text{Total land area (size)}}$$

Hatchability of eggs: This determines the fertile or viable eggs that successfully hatch into chicks under the required conditions within a given period of time.

$$\text{Hatchability of eggs} = \frac{\text{Hatched chicks} \times 100}{\text{Total number of eggs}}$$

Total profit (T.P): Profit is very important in agriculture because every farmer, or profession related to agriculture, aims to make a profit at the end year or growing season. The revenue must exceed the total cost or expenses for the farmer to make profit.

$$\text{Total profit (T.P)} = \text{Total revenue} - \text{Total cost}$$

Activity 2.7

1. Visit any commercial farm (crops or animals farm) in your community and find out how some of the basic parameters are measured.
2. Write a report on your visit and present your findings to the whole class. In writing your report be guided by the following;
 - a. The parameters that were measured during your visit.
 - b. Describe how the parameters were measured.
 - c. If applicable, outline any calculations involved in interpreting and/or converting the raw data into usable information.
 - d. Indicate any challenges or practical considerations related to measuring the parameters.

Activity 2.8

Discuss in pairs the importance of measuring an identified parameter in agricultural production. In your discussion consider the following

- a. The effect of the parameter on Agricultural production.
- b. The importance of measuring the parameter in agricultural production.
- c. The potential consequences of not measuring the parameter in agricultural production.

MEANING AND IMPORTANCE OF FARM MECHANISATION AND POWER

Meaning of Farm Mechanisation and Power

Farm mechanisation refers to the application of engineering principles and technology in agricultural settings. It may also be defined as the use of machines and equipment in agricultural production to improve efficiency, productivity and reduce manual labour.

Farm power refers to the energy or force used to perform various tasks in agricultural production. Power is used on the farm for various activities including land clearing and preparation, fertiliser application, harvesting, pumping and transportation of water, planting of seeds, etc.

The sources of power for farm use include:

1. **Human power:** This is the main source of farm power in most developing countries. This is where human beings use their physical and mental abilities to perform agricultural tasks such as manual tilling, harvesting or carrying loads.
2. **Animal power (draught animals):** This is the use of draught animals such as oxen, camels, donkeys, horses and other domesticated animals to perform agricultural tasks that can also be done by humans and machines on the farm.
3. **Mechanical power (internal combustion engines):** Involves the use of machinery, engines or motors to perform tasks, such as ploughing, planting, irrigation, and crop processing.
4. **Wind power:** This is the conversion of wind energy into a useful form of energy, typically electricity, using wind turbines.
5. **Electric power:** It is simply referred to as electricity and is the flow of electrical energy through a conductor, typically in the form of a current. It is a fundamental form of energy used in various applications across the agricultural industry.

6. **Water power:** Water power, also known as hydro or hydro-electric power, is the utilisation of the energy contained in flowing water to generate electricity or perform mechanical work such as feed grinding.
7. **Solar power:** This is the power generated from the sun. Solar power harnesses the energy from the sun's rays to generate electricity or heat on the farm. This energy is used for processing fruits and vegetables and for general drying of crops.
8. **Biogas:** This is the generation and utilisation of gases arising from decomposing biological wastes.

Importance of Farm Mechanisation and Power

1. **Labour savings and cost reduction:** It helps farmers to reduce their dependency on manual labour, which can be costly and scarce sometimes depending on the season. This leads to cost savings for farmers and enables them to allocate labour costs to other activities.
2. **Increased efficiency and productivity:** Well-maintained and properly functioning machinery enables faster and more accurate completion of tasks, saving time, labour and leading to increased productivity per unit of land.
3. **It reduces health hazard:** Mechanisation helps to reduce the health hazard associated with farm tasks. There is less health hazards associated with the use of machines on the farm than using manpower.
4. **Reduce the level of drudgery:** The use of machines in agriculture enables farmers to undertake jobs which would be impossible to do manually. It helps farmers to do difficult and unpleasant jobs more easily and, at times, more effectively.
5. **Encourages large scale farming:** The use of machines encourages farmers to go into large scale agricultural production. Without the use of farm machinery, large scale production in agriculture is just not feasible.
6. **Ensures quality and accuracy of farm operations:** The use of machines helps farmers to perform tasks on the farm to meet quality standards and accuracy.
7. **Timely operations:** Mechanised equipment allows farmers to perform field operations in a timely manner, optimising planting and harvesting schedules and reducing the risk of crop losses due to adverse weather conditions.
8. **Improve soil properties:** When soil preparation is mechanised, it helps improve the soil's physical properties such as porosity, structure, capillarity, infiltration, etc. However, care must be taken not to use heavy machinery too much on the farm land as it can cause significant compaction of the soil and could eventually reduce infiltration rates..

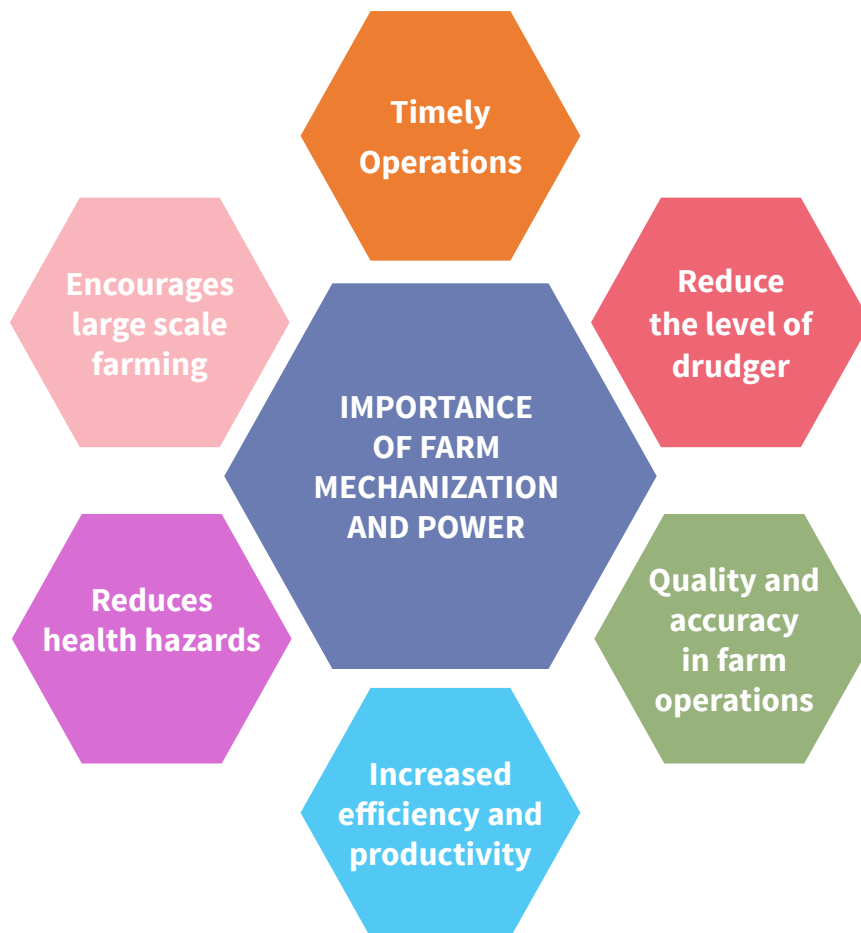

Fig. 2.4 Some importance of farm machinery and power

Activity 2.1

1. What comes into mind when you hear the term 'farm mechanisation and power'? Write your ideas and thoughts on a piece of paper.
2. Surf the internet/magazines to compare your ideas about farm mechanisation and power.
3. Put the ideas together to come up with a meaning of farm mechanisation and power.

Activity 2.2

1. Visit a mechanised farm in your community or watch a video on a mechanised farm by clicking [here](#)
2. Document the farm machine used in their operations.
3. With the help of the internet and other resources, identify:

- a. The name of the machines.
- b. Farm operations that the machine performs
- c. Compare your findings with a peer for feedback.

Activity 2.3

1. Watch a documentary/video/picture on traditional farm methods and mechanised farm methods by clicking [here](#)
2. Compare the two farming methods based on:
 - Farm activity
 - Time used to complete the task
 - Level of difficulty in completing the farm task
 - Level of precision of the activity
3. Input your findings in the table below:

	Traditional farm methods	Mechanised farm methods
Activity		
Time		
Level of difficulty		
Level of productivity		
Level of precision		

- a. Based on your findings, what conclusions can you draw?
- b. Write the importance of using farm mechanisation and power in agricultural production. Share your findings with your peers.

SAFETY MEASURES EMPLOYED IN OPERATING FARM MACHINES AND POWER

What are Safety Measures?

They are precautions or actions taken to prevent or minimise risks, hazards or injuries in a particular situation or environment, as well as preventing the destruction of machines, tools and their parts.

Precautions to Take When Operating Farm Machines and Power

1. **Read the manufacturer's manual:** Every machine has the manufacturer instructions. Every operator must understand a machine's operations, safety measures and instructions before use.
2. **Personal protective equipment (PPE):** Wearing appropriate PPE is essential for operator safety. This includes items such as helmets, safety goggles, ear protection, overalls, gloves, and safety boots. PPE helps protect against potential hazards like flying debris, noise, chemicals, and falls.
3. **Machine inspection and maintenance:** Regular inspection and maintenance of farm machines is necessary to ensure they are in proper working condition and fit for purpose. This includes checking for worn-out or damaged parts, proper lubrication, and keeping safety features, such as guards and shields, intact. Pay attention to brakes, light and other critical components.
4. **Training and education:** Proper training and education on the safe operation of farm machines is crucial. Operators should receive comprehensive training on the specific machinery they will be operating, including understanding controls, safety features, and safe operating procedures.
5. **Keep children away from machines:** Ensure that children are not in the working area or where the machine is operating. Keep certain machines such as tractors locked when not in use, if possible, to prevent children from getting inside the cab and altering settings.
6. **Use safety features:** Ensure machines are equipped with safety features like seatbelts and roll-over protection structures.
7. **Avoid fatigue:** Operating farm machinery requires concentration and focus. Take regular breaks to prevent fatigue, which can impair judgment and reaction times, increasing the risk of accidents.
8. **Use safety signals:** Use proper hand signals or communication devices when working with others around machinery. Establish clear communication and ensure everyone understands their roles and responsibilities.
9. **Be aware of surroundings:** watch out for obstacles, power lines, underground pipes and other hazards in the work place.

- 10. Avoid eating and drinking when operating a machine:** Eating and drinking can divert attention from the task at hand leading to reduced focus on the operation of the machine. Eating or drinking near machines may expose workers to dust or contaminants leading to poison or infection.
- 11. Avoid Smoking when operating a machine:** Many machines involve flammable materials such fuel, oil and other chemicals and smoking near these materials can lead to fire or explosions posing a serious threat to both the operator and others nearby. Focusing on smoking can cause significant destruction increasing the risk of accidents.



Fig 2.5 Some examples of PPE used in agriculture

Activity 2.4

1. With the help of the internet, magazines or other resources, get information on safety measures that should be observed during the operations of farm machines. Use the following guidelines:
 - a. Type of farm machine.
 - b. What hazards are associated with operating the farm machine?
 - c. What personal protective equipment (PPE) should be worn when operating the farm machine?
 - d. What safety measures should be put in place when operating the farm machine on the farm?
 - Share your views with your peers.

Activity 2.5

1. Visit any farm machinery workshop in your community or watch documentary/pictures on safety protocols that are observed while carrying out farm operations by clicking [here](#).

During the visit/documentary take note of the following:

- a. Activities that are carried out at the workshop.
- b. The PPE used in operations and their functions.
- c. The accidents and injuries that could occur if the appropriate PPE is not worn.
 - Write your findings and share with your peers.

Activity 2.6

1. In pairs, Identify a farm activity such as preparation of vegetable beds, application of fertilisers, application of weedicides, etc. in the school farm or at a backyard garden under supervision of a technician or experienced personnel.
2. Document the PPEs that you will require before performing any farm activity and the reason why you will wear them.
3. Carry out the activity, making sure you always follow safety procedures.
4. As you are performing the farm activities, what extra safety measures could you put in place to avoid accidents and injuries.
5. Share your ideas with your peers for feedback.

INJURIES IN AGRICULTURAL PRODUCTION

1. Meaning and causes of injuries in agricultural production

Injuries in agricultural production refer to physical harm or damage suffered by individuals involved in farming and other agricultural activities.

2. Causes of injuries in agricultural production

The following are some causes of injuries in agricultural production:

- a. **Machinery and equipment:** Working with farm machinery such as tractors and combine harvesters can pose significant risks including entanglement, crushing, and amputation hazards.

- b. Slips, trips and falls:** Farming involves working in various terrains and weather conditions such as uneven ground (e.g. fields) or slippery surfaces, which can increase the risk of slips, trips and/or falls, resulting in injuries.
- c. Chemical exposure:** Pesticides, fertilisers and other chemicals used in agricultural production can lead to health issues and injuries if not handled properly or if safety measures are not followed.
- d. Animal-related incidents:** Livestock, such as cattle, can cause injuries through kicks, bites or trampling.
- e. Falls from heights:** Working at heights, such as operating machinery on elevated platforms, can lead to falls and serious injuries.

3. Type of injuries in agricultural production

The following are types of injuries in agricultural production:

- 1. Abrasions:** Superficial injuries that involve scrapes or grazes to the skin. They usually result from friction or rubbing against a rough surface.
- 2. Lacerations:** Cuts or deep wounds that result from sharp objects or tools.
- 3. Bruises:** These, also known as contusions, occur when blood vessels beneath the skin rupture due to blunt force trauma. They often appear as discoloured areas on the skin.
- 4. Fractures:** Broken bones resulting from significant force or impact on the skeletal system.
- 5. Burns:** Injuries caused by exposure to heat, fire, chemicals, electricity, radiation or friction.
- 6. Dislocations:** Displacement of a bone from its normal position at a joint.
- 7. Strains:** Injuries to muscles or tendons which are the fibrous tissues that connect muscles to bones.
- 8. Sprains:** Injuries to ligaments which are the connective tissues that join bones together at joints.
- 9. Puncture Wounds:** Deep injuries caused by sharp objects penetrating the skin such as nails, needles or shards of glass.
- 10. Crush injuries:** Injuries that occur when a body part is squeezed or compressed between two (2) objects such as large livestock, heavy machinery or collapsing structures.
- 11. Poisoning:** Poisoning is the harmful effects of herbicides, pesticides, and cleaning fluids entering the body through ingestion, inhalation or skin absorption.
- 12. Skin irritations:** Skin irritations refer to adverse reactions or inflammation of the skin.
- 13. Respiratory problems:** Respiratory problems encompass a range of conditions affecting the lungs and the respiratory system. These problems may include coughing, wheezing, shortness of breath, occupational asthma, bronchitis or other respiratory disorders. They are often caused by dust, spores and high pollen levels.

- 14. Eye injuries:** Eye injuries occur when the eyes are exposed to harmful substances, foreign objects or trauma. In agricultural settings, eye injuries can result from flying debris, particles, chemicals or direct impact from tools or equipment

Activity 2.7

In pairs, explore and define the meaning of occupational injuries in agricultural production using the following as a guide:

- What comes to mind when you hear the word ‘injury’?
- How do you relate your understanding of injuries to agricultural production?
- Write the meaning of injury in agricultural production on a piece of paper and share with your peer.

Activity 2.8

1. Read the following scenarios carefully:
 - a. A farm worker, attempting to fix a malfunctioning item of farm machinery without turning it off gets his hand caught in the machinery, resulting in severe injury.
 - b. An agricultural worker, spraying pesticides on a large field, decided not to wear protective gear, because she finds it uncomfortable. She later experienced vomiting, dizziness and skin irritation.
 - c. During a routine check, a farmhand inspecting a group of cattle gets kicked by agitated cattle causing him to fall and break his arm.
 - d. A farm worker working in a greenhouse, where the floor is wet and slippery due to irrigation, slips and falls, injuring herself.
 - e. During a hot day, a farmer working in the fields from morning until afternoon without adequate breaks or hydration collapses due to heat stress.

Task

1. Identify and document the potential hazards and unsafe practices which are in each scenario.
2. Write the consequences and implications of the hazards and unsafe practices in the scenarios to the agricultural worker.
3. Compare your findings with your peers and clarify the differences.

Activity 2.9

1. Click [here](#) and watch a documentary on the different types of injuries in agricultural production.
2. Identify and categorise the injuries in the documentary based on the type of injury, causes of the injury and body parts affected.
3. Input your findings in the table below.

Type of injury	Causes of the injury	Body part affected

Do you have any experience with any of the injuries shown in the documentary? Share with your peers.

CONTENTS OF FIRST AID BOX AND THEIR USES

The following are some contents of a first aid box and their uses:

- Adhesive bandages:** These are used to cover small cuts, scrapes or minor wounds. They help protect the wound from dirt and bacteria and promote healing. Always check that the person isn't allergic to them before applying.
- Sterile gauze pads:** Gauze pads are used for cleaning and covering larger wounds or cuts. They are sterile and absorbent, helping to control bleeding and prevent infection.
- Adhesive tape:** Tape is used to secure dressings or bandages in place. It provides support and helps keep the dressing clean and intact.
- Antiseptic solution or wipes:** These are used to clean the skin around wounds or cuts, reducing the risk of infection. Common antiseptics include alcohol-based solutions or antiseptic wipes.

- e. **Disposable gloves:** Gloves are essential for personal protection when providing first aid. They help prevent the spread of germs, protect the care giver, and maintain a sterile environment.
- f. **Scissors:** Scissors with rounded edges are included to cut tape, gauze or clothing when necessary. They are useful for removing clothing from an injured area or cutting bandages to the desired size.
- g. **Tweezers:** Tweezers can be used to remove small splinters, foreign objects or debris from wounds. They provide a precise grip and help maintain cleanliness.
- h. **CPR mask or face shield:** These devices are used when performing cardiopulmonary resuscitation (CPR) to provide a barrier between the rescuer and the person receiving the CPR. They help prevent the transmission of infections.
- i. **Instant cold packs:** Cold packs are used to reduce swelling, inflammation, and pain associated with injuries. They are activated by squeezing or shaking and provide immediate cooling.
- j. **Pain relievers:** Non-prescription pain relievers such as acetaminophen or ibuprofen, can be included in the kit to provide temporary relief from minor aches, pains, or fever.
- k. **Emergency contact information:** It's important to have a list of emergency phone numbers, including local medical facilities, poison control centres and emergency services. This information ensures quick access to appropriate help during an emergency.



Fig 2.6 Some items found in a first aid box

Implications of using inappropriate first aid materials and treatments of wounds

- a. **Delayed or inadequate wound healing:** Inappropriate first aid materials, such as non-sterile or dirty bandages, can introduce bacteria or contaminants to the wound, leading to infection and delaying the healing process.
- b. **Increased risk of infection:** Using non-sterile materials or applying chemicals that are not intended for wound care can increase the risk of infection.
- c. **Allergic reactions:** Some individuals may have allergies or sensitivities to certain materials or chemicals. Using inappropriate first aid materials or applying chemicals on wounds can trigger allergic reactions, ranging from mild skin irritation to severe allergic responses such as swelling, itching or difficulty breathing.
- d. **Tissue damage and scarring:** Improper application of chemicals on wounds, especially those that are caustic or corrosive, can lead to tissue damage.
- e. **Prolonged pain and discomfort:** Using inappropriate materials or chemicals can cause unnecessary pain and discomfort for the individual.

Indigenous ways of providing first aid to injured persons at a farm site

- a. **Medicinal plants and herbs:** Many indigenous communities have a deep understanding of local plants and their medicinal properties. Traditional healers or community members may use specific herbs, leaves or roots to create poultices, infusions or ointments to treat wounds, reduce inflammation or alleviate pain.
- b. **Traditional bandaging techniques:** Indigenous communities may have their unique methods of bandaging wounds. This can include the use of natural fibres, such as plant leaves or tree barks, to create bandages or splints to immobilise injured limbs.
- c. **Heat and cold therapies:** Indigenous practices sometimes utilise heat or cold therapies for managing pain and inflammation. For example, applying heated or cooled natural substances, such as warmed stones or cold water, to the injured area may be believed to provide relief and reduce swelling.
- d. **Spiritual and cultural beliefs:** Indigenous first aid practices often incorporate spiritual and cultural beliefs. Ceremonies, prayers or rituals may be performed alongside physical treatments to provide emotional support, invoke healing energy or seek guidance from ancestral spirits or deities.
- e. **Traditional bone setting:** Some indigenous cultures have specialised individuals known as bone healers or traditional bone setters who possess unique knowledge and skills in setting fractures and dislocations.

Safety measures in handling accidents and injuries of an agricultural worker

Provide first aid: Apply appropriate first aid techniques to stabilise the injured worker while waiting for medical professionals to arrive.

The specific first aid procedures will depend on the nature of the injury, but some common steps include:

- a. Assess the situation: Assess the scene to ensure your safety and identify any potential hazards. Take necessary precautions to prevent further harm to yourself and others involved.
- b. Ensure the injured person has an open airway and is breathing.
- c. Control bleeding by applying direct pressure to the wound with a clean cloth or bandage.
- d. Immobilise any suspected fractures or spinal injuries by keeping the injured person still and using splints or other appropriate immobilisation techniques.
- e. If the injury is severe or life-threatening, immediately call for emergency medical assistance or instruct someone to do so. Provide accurate details about the location, nature of the injury and any other relevant information.
- f. Administer CPR (cardiopulmonary resuscitation) if necessary and if you are trained to do so.
- g. Reassure the injured worker and try to keep them calm. Offer comfort and support while awaiting medical help. Keep them warm and provide reassurance that help is on the way.
- h. It is important to document the incident, including details of the injury, the first aid provided and any witnesses. Report the incident to the appropriate authority within your organisation or follow the established reporting procedures.

Activity 2.10

1. With the aid of the internet ([click here](#)), first aid manuals and health organisations guidelines, list the essential contents of a first aid box/kits. Consider the different types of injuries that can occur in an agricultural production (e.g. cuts, burns, sprains, allergic reactions) when listing the items.
2. For each item listed, write a brief justification note using the following guidelines:
 - The purpose of the item.
 - How and when it is or should be used.
 - The importance of including it in the first aid box.

Example: *Bandages - Used to cover and protect minor cuts and wounds, preventing infection and promoting healing.*

- Share your findings with a friend.

Activity 2.11

1. Watch a documentary ([Click here](#)) or listen to a professional health worker or a first aider on the complications of using inappropriate first aid materials and techniques in agricultural production.
2. Based on the documentary or talk, identify:
 - a. Inappropriate materials and techniques used in first aid administrations in agricultural production.
 - b. The consequences of using inappropriate first aid materials and techniques in agricultural production.
1. Share your experience of using inappropriate first aid materials and techniques with your peers, explaining the complications experienced and how it was solved.

Activity 2.12

1. Engage in a brainstorm exercise using the following leading questions.
 - a. What common injuries can happen at a farm site?
 - b. How do people in your community traditionally treat these injuries?
 - c. What specific plants or materials are used in your community to treat injured persons?
 - d. How are these local plants and materials prepared and applied to the injuries?
 - e. Are there any cultural practices or beliefs associated with these treatments?
1. Compare your findings with your peers and share ideas on different traditional ways of providing first aid to injured persons.
2. If you have experience assisting an injured person using a local material/method, share it with your peers.

Read the Case Study Carefully

John, a farmer, was bitten by a snake while working in his fields. Instead of going to the hospital, he decided to follow a local practice. The village elder instructed him to make a poultice using certain herbs known for their anti-venom properties and to tightly tie a cloth above the bite (a tourniquet) to prevent the venom from spreading. John applied the poultice and tied the cloth as instructed. However, the poultice caused an allergic reaction, leading to severe swelling and pain. The tight cloth restricted blood flow, causing tissue damage around the bite area. By the time John reached the hospital, he had developed necrosis (death of body tissue) around the bite, requiring more extensive medical treatment.

Based on the case study, discuss the following questions with your friends.

1. What are the dangers of using unverified herbal poultices?
2. How can tight tourniquets cause additional harm in snake bite cases?
3. What modern treatments could have been used by John?
4. Share your findings with your peers for feedback and discussion.

Hint

Note that after administering first aid, the injured person should be made to seek medical attention.

GENERAL SAFETY WORKING PRACTICES AND RISK ASSESSMENTS

The following are some general safety working practices in agricultural production:

1. **Training and education:** Provide comprehensive training for all workers on safe work practices, machinery operation, and emergency procedures. Ensure that workers are familiar with the potential hazards associated with specific tasks and equipment.
2. **Personal protective equipment (PPE):** Require the use of appropriate PPE such as gloves, safety goggles, hearing protection, and respiratory protection, depending on the task. PPE is important because it prevents physical injury, protects against chemical exposure, prevents biological hazards, protects against heat and the sun, prevents musculoskeletal injuries and provides safe means of handling. Regularly inspect and maintain PPEs to ensure their effectiveness.
3. **Machinery safety:** Conduct regular maintenance and inspections of all farm equipment to identify and address potential issues. Train operators in safe operation of machinery and equipment. Keep guards and shields in place and ensure all safety features are functional.

4. **Chemical handling and storage:** Provide training on the proper handling, storage, and disposal of agricultural chemicals. Ensure workers are aware of the location of emergency equipment, such as eyewash stations and emergency showers.
5. **Manual handling:** Encourage proper lifting techniques to prevent injuries. Provide mechanical aids when handling heavy loads and implement safe practices.
6. **Fall prevention:** Install guardrails, safety nets, or personal fall arrest systems when working at heights. Train workers on the proper use of fall protection equipment.
7. **Animal handling:** Train workers on safe animal handling practices. Provide appropriate facilities and equipment for handling livestock.
8. **Emergency procedures:** Develop and communicate emergency response plans, including evacuation procedures and first aid protocols. Ensure the availability of first aid kits and fire extinguishers.
9. **Field and environmental hazards:** Identify and address environmental hazards such as uneven terrain, wildlife, and adverse weather conditions. Implement measures to protect workers from extreme temperatures and sun exposure including checking weather forecasts before undertaking tasks.
10. **Regular safety inspections:** Conduct regular safety inspections of the entire farm, including equipment, buildings, and work areas and record any problems or issues found. Promptly address any identified hazards or issues.
11. **Communication:** Foster open communication between workers and management regarding safety concerns. Encourage reporting of near misses and incidents for continuous improvement.
12. **Regulatory compliance:** Stay informed on local, regional, and national safety regulations and standards, and comply with them.

Risk Assessment in Operating Farm Equipment and Machinery

The following are some risk assessment guidelines in operating farm machinery:

1. **Identification of hazards:** The first activity in risk assessment is to identify potential hazards associated with the specific equipment, tools or machinery being used. This could include moving parts, sharp edges, electrical components or environmental factors such as uneven terrain and adverse weather conditions.
2. **Assess risks:** Once hazards are identified, evaluate the level of risk associated with each. Consider the likelihood of an accident occurring and the potential severity of the consequences.
3. **Determine appropriate control measures:** Develop control measures to mitigate or eliminate the identified risks. This could involve engineering controls like machine guarding, administrative controls like implementing safe operating procedures or wearing personal protective equipment (PPE) like helmets, gloves or safety goggles.

4. **Implement control measures:** Put identified control measures into practice. This may involve modifying equipment, providing training to operators or establishing safety protocols for using the equipment or machinery in specific conditions.

Activity 2.13

1. Take a safety walk to a local farm or watch a video on safety in a farm environment [Here](#)
2. Identify the safety measures and potential hazards in the farm environment using the following questions:
 - a. What safety signs and warnings are posted around the farm?
 - b. What emergency procedures or equipment are visible?
 - c. How are dangerous areas (like machinery zones or chemical storage) marked and secured?
 - d. Are workers wearing appropriate protective gear?
3. Share your observations with your peers and discuss how safety measures in farm sites can be improved.

TYPES AND USES OF FARM MACHINES

Farm machines are mechanical devices with moving parts capable of generating power to accomplish tasks on the farm, and farm implements are complex farm tools which require a source of external power to perform farm operations.

Machines and Implement Use in Crop Production

1. **Tractors:** Used for ploughing, planting, harvesting, hauling and general fieldwork. Tractors can be equipped with various attachments by means of power take-off (PTO), which transfers power from the tractor engine to the attached equipment.
2. **Combine harvesters:** They are complex machines that perform multiple harvesting functions. These functions include:
 - a. **Harvesting:** Combines are used to harvest a variety of crops, including wheat, rice, oats, barley, corn (maize), millet, sorghum, soybeans, flax, sunflowers, etc.
 - b. **Threshing:** They separate the edible part of the grain from the non-edible chaff.

- c. **Cleaning:** The combine harvester cleans the grain during the harvesting process which is ready for storage.
- 3. **Planters and seed drills:** Planters and drills ensure even distribution of seeds uniformly across the field, reducing seed waste and promoting healthy and optimal growth of plants.
- 4. **Sprayers:** They are used for applying pesticides, fertilisers, irrigation, herbicides, and fungicides in crop production. Sprayers come in various types including hand-operated, low-pressure, high-pressure, air-carrier and foggers suited for different scales of farming operations.
- 5. **Harvesters:** They are used for harvesting specific crops such as fruits, vegetables and forage. Harvesters can be designed for different crops. They harvest crops by combining three separate farming operations, reaping, threshing and winnowing, into a single process.
- 6. **Balers:** They are used for compacting and baling harvested crops, such as hay, straw, or silage, into manageable and transportable bundles for storage or livestock feed.
- 7. **Tillage equipment:** They are used to prepare soil for planting by breaking up and smoothing the surface to the desired condition through mechanical processes like pulverisation and cutting. They also incorporate crop residues and help control weeds. Examples of such tools include ploughs, harrows, and cultivators.
- 8. **Irrigation systems:** They are used in providing controlled water supply to crops for optimal growth. Irrigation systems can be sprinkler-based, drip irrigation or flood irrigation.

Machines and Implement Use in Animal Production

- 1. **Feed mixers:** They are used for mixing and preparing animal feed, combining different ingredients like grains, forages and supplements to create a nutritionally balanced ration to promote growth and health. Feed mixers ensure uniform distribution of feed components such as proteins, vitamins, carbohydrates, and minerals.
- 2. **Silage harvesters:** They are utilised to gather and mince forage plants like corn or grass for ensiling. These machines trim the plants into fine segments and transfer them into a trailer, which is then used for transportation and storage.
- 3. **Milking machines:** They are used for mechanised milking of dairy animals, such as cows or goats. Milking machines automate the milking process, enhancing efficiency and reducing labour requirements, accidents and injuries, hygiene and animal welfare. Examples of different types of milking machines are buckets pipelines, robotics and biosensors.
- 4. **Manure spreaders:** They are used to apply animal manure to fields as an organic fertiliser. Manure spreaders ensure even distribution of manure, which enhances soil fertility, nutrient recycling, and soil health by improving structure, aeration, and water retention. There are different types of manure spreaders, including tractor-based and ground-based models, each tailored to various farm sizes, terrains, and requirements.

5. **Ventilation systems:** They are used to provide optimal air circulation and regulate temperature and humidity in livestock buildings. Ventilation systems maintain a comfortable and healthy environment for animals, particularly in intensive animal production systems, ensuring air quality, minimising emissions, disease, and allergy control.
6. **Automatic water dispensers:** They are used to supply a continuous and clean water source to animals. Automatic water dispensers ensure that livestock always have access to fresh water, reducing labour and wastage associated with manual watering.
7. **Cattle scales:** They are used for monitoring growth, determining feed efficiency, and managing herd health. Cattle scales enable accurate weight measurement, aiding management decisions, and disease prevention.
8. **Egg collectors:** They are used to collecting eggs from poultry houses automatically. Automatic egg collectors reduce labour and handling stress on hens, improving efficiency in egg production.

Machines and Implement Use in Fish Production

1. **Fish feeders:** They are used to distribute feed to fish in aquaculture systems.
2. **Oxygenation systems:** These systems are used to maintain adequate oxygen levels in fish ponds or tanks, examples include aerators and diffusers.
3. **Filtration systems:** They are employed to remove waste, excess feed, and other impurities from fish tanks or ponds.
4. **Fish graders:** They are used to sort fish by size.
5. **Fish counters:** These are devices that automate the counting of fish in aquaculture systems.
6. **Fish vaccinators:** These are specialised equipment that facilitate the efficient and safe administration of vaccines to fish, often through injection or immersion method.
7. **Fish processing equipment:** This includes machinery used for cleaning, filleting, deboning, and packaging fish for the market.
8. **Monitoring equipment:** These are various instruments and sensors, such as pH metres, dissolved oxygen metres, and temperature probes, which are used to monitor and assess water quality parameters in fish production systems.
9. **Boat and netting equipment:** In commercial fishing operations, boats, nets, and fishing gear are utilised for capturing fish from natural water bodies. These include trawlers, seine nets, gill nets, and other fishing implements.



Fish Pond Aerator



Tractor



Incubator



Pesticide Applicator



Sprinkler



Seed Planter



Combine Harvester

Fig 2.7 Some machines used in agricultural production



Planter



Automatic Water Trough



Disc Plough



Thresher



Ridge



Cultivator



Rotary Tiller



Disc Harrow



Potato Harvester

Fig 2.8 Some implements used in agriculture

Types of Farm Power Units and Their Uses

Human power: Human power in agriculture refers to the physical labour provided by farmers and agricultural workers. Human labour is employed in tasks such as manual harvesting, hand weeding, planting, and other activities that require natural or acquired skills and precision.

Advantages

1. Cost-effective
2. Accessibility
3. Precision and flexibility
4. Environmentally friendly and sustainable
5. Health and fitness
6. Cultural preservation
7. No risk of power failure

Disadvantages

1. Labour intensive
2. Time-consuming
3. Physical limitations
4. Limited capacity
5. Seasonal and weather dependency
6. Skill requirements
7. Health risks

Animal (draught) power: Animals, such as horses, buffalos, donkeys, oxen, and mules are utilised for tasks like ploughing, pulling carts or wagons, harrowing, and transportation of goods on the farm.

Advantages

1. Animals can perform a wide range of farm tasks including ploughing, harrowing, cultivating, hauling, and transportation.
2. Animal power is a renewable energy source that does not rely on fossil fuels and is environmentally friendly.
3. Animals are often available on the farm or can be easily acquired or rented from nearby sources.
4. Low cost as compared with the purchase, maintenance, and fuelling of machinery.
5. Animals distribute their weight more evenly, reducing soil compaction and erosion. Also, their faeces add manure to the soil, fertilising and conserving the soil.
6. Draught animals are a source of meat when they outlive their usefulness.

Disadvantages

1. Working with animals requires proper training, knowledge, and expertise.
2. Animals require regular care including feeding, grooming, veterinary attention, and suitable shelter.
3. Animals have physical limitations in terms of power and speed compared to mechanised equipment.
4. Animals are subject to seasonal variations such as periods of rest, breeding or growth, which can impact their availability or performance.
5. Animal-powered operations may be slower and less efficient compared to mechanised alternatives.

Mechanical power: Mechanical power involves the use of machines powered by engines or motors for a wide range of farm operations. Examples include internal combustion engines (typically diesel or gasoline).

Advantages

1. Mechanised equipment is typically more powerful and faster than manual or animal-powered methods.
2. Mechanised equipment can offer precise control over operations such as planting, fertilising, spraying and harvesting.
3. Mechanisation reduces the time required to perform labour-intensive tasks, allowing farmers to focus on other important aspects of their operations.
4. Mechanisation reduces the need for a large workforce, especially for repetitive or physically demanding tasks.
5. Machinery provides greater power and capacity compared to human or animal power.

Disadvantages

1. Mechanised equipment can be expensive to purchase, operate, and maintain.
2. Most mechanical power units rely on fossil fuels such as gasoline, diesel or propane which can result in significant operating costs, vulnerability to fuel price fluctuations and environmental impacts.
3. Operating and maintaining machinery requires technical knowledge and skills. Farmers need to be trained in equipment operation, maintenance, troubleshooting, and safety protocols.
4. Mechanised operations, especially when not implemented sustainably, can have environmental consequences.
5. They can also cause soil compaction, erosion, noise pollution. Chemical runoff from machinery can negatively impact soil health, water quality, and biodiversity if proper management practices are not followed.
6. Mechanised equipment may not be suitable or accessible for certain terrains, small plots or in regions with limited infrastructure.

Electrical power plays a vital role in modern agricultural operations. It is used for a variety of purposes on farms, including lighting, electric fences, water pumping, and operating milking machines. Some modern farm machinery is now electric battery powered.

Advantages

1. Electrical power can be utilised to operate a wide range of agricultural machinery and equipment, including irrigation systems, pumps, and milking machines.
2. Electrically powered machinery and equipment are generally more efficient than their non-electric counterparts.
3. Electrical power from the grid or generated by generators is generally reliable and consistent.
4. Compared with fossil fuel-powered alternatives, electrical power has a lower environmental impact.
5. Electrical power enables automation and control systems in farm operations, improving efficiency and precision.

Disadvantages

1. Establishing electrical power infrastructure on farms, including wiring, transformers, distribution panels, charging points and their connection to the grid, can involve significant costs.
2. Farms relying on electrical power from the grid are subject to potential power outages or disruptions.
3. While electrical power may be cost-effective compared with some other power sources, farms still incur on-going operating costs, including electricity bills.
4. Electrical power is typically stationary and requires a fixed infrastructure.

5. While electrical power itself has a lower environmental impact, the generation of electricity can have environmental consequences depending on the energy source.

Renewable energy: Farms are increasingly adopting renewable energy systems like solar panels, wind turbines, biogas, water turbines, and battery systems to generate electricity, which can power various farm operations or contribute to grid supply. By integrating renewable energy sources into farm operations, farmers can reduce their carbon footprint, save on energy costs, and improve the sustainability of their agricultural practices.

Advantages

1. Renewable energy sources produce minimal greenhouse gas emissions and have a significantly lower environmental impact compared with fossil fuel-based power generation.
2. In the long term, renewable energy can lead to cost savings for farms.
3. Renewable energy allows farms to become more self-sufficient and less reliant on external energy sources.
4. The adoption of renewable energy can stimulate rural economic development. Farms can become producers and sellers of renewable energy, contributing to job creation and revenue generation for local communities.
5. Renewable energy sources provide long-term stability and price predictability.

Disadvantages

1. The initial investment in renewable energy systems can be high, including the cost of equipment, installation, and maintenance.
2. Renewable energy sources, such as solar and wind, are subject to intermittency and variability.
3. Some renewable energy systems, such as large-scale solar or wind farms, require significant land or space.
4. Certain renewable energy technologies may still have technological limitations or require specialised knowledge for installation, operation, and maintenance.
5. While renewable energy sources have a lower environmental impact, they still have some associated environmental considerations.



A tractor with a PTO



Solar Power



Wind Power



Drought Power

Out Board
Motor

Human Power



Generator



Internal Combustion Engine

Fig 2.9 Examples of sources of power used in agricultural production

Activity 2.14

1. Visit a local farm where machines are in operation or watch videos/pictures about farm machines and power.
2. Identify and describe the different types of farm machinery used on the farm during the visit or when watching of the videos. Use the following guiding questions:
 - a. What is the name of the farm machine?
 - b. What farm activity is the machine used?
 - c. What is the structure of the machine? That is number of wheels, the frame, control systems, attachments and implements, safety systems.
 - d. What operation method is hand-operated, mechanised or draught-operated?

Activity 2.15

(This activity should be carried out under supervision of a technician)

1. Observe a hands-on operation of a farm machine/implement by a technician or watch a video on the operation of farm machines.
2. Guided by the technician, operate the farm implement provided. Follow the checklist below:
 - a. Putting on protective gear.
 - b. Doing risk assessment (checking that all the parts are well fixed and the machine is in good condition).
 - c. Following instructions from the technician operate the machine correctly and safely for the assigned farm activity.

Caution

- i. Only handle equipment under supervision of the technician.
- ii. Do a thorough risk assessment of the machine before operating it.
- iii. Always put on the prescribed protective gear before operating the machine.

Activity 2.16

1. With the help of the internet and other resources, examine the operation of the following farm machines:
Tractor for ploughing and harvesting
 - a. Irrigation system
 - b. Feed grinder/feed mill
 - c. Water heater
 - d. Ventilation system
 - e. Seed drills
 - f. Fish pond aerator
 - g. Incubator
2. Write the type of power source that is used to operate the listed machines and equipment. Present your finding in a table.

Type of machine	Power source
Tractor for ploughing and harvesting	
Irrigation system	
Feed grinder/feed mill	
Water heater	
Ventilation system	
Seed drills	
Fish pond aerator	
incubator	

3. From your findings, list the types of power sources used in agricultural production.
4. Compare your findings with your peers and discuss the advantages and disadvantages of using the identified power sources in agricultural production.

FACTORS THAT AFFECT THE USE OF FARM MACHINES AND POWER SOURCES

Key Factors that Influence The Efficiency of Farm Machines and Power Sources

Efficiency of machines and power sources refers to how effectively these tools and energy sources perform agricultural tasks while minimising waste and maximising productivity. It's about using the right amount of power to achieve the desired farming outcomes without excess expenditure of energy resources.

1. **Machine selection:** Choosing the right machine for a specific task is crucial. The type of crop, field conditions, terrain, and desired level of automation should be considered when selecting a machine. Selecting a machine that is well-suited to the task at hand can enhance efficiency and productivity and increase safety.
2. **Maintenance and upkeep:** Regular maintenance and upkeep of farm machinery is essential for optimal performance. Proper lubrication, cleaning, and timely repairs help prevent breakdowns, reduce downtime, and ensure efficient operation.

3. **Operator skill and training:** The skill and training of the machine operator will significantly influence efficiency. Well-trained operators can operate machines more effectively, make appropriate adjustments, and address minor issues promptly, leading to improved efficiency and reduced fuel consumption.
4. **Farm management practices:** Effective farm management practices, such as proper planning, scheduling and coordination, can enhance the overall efficiency of machinery operations. Optimal field layout streamlined workflow and well-managed logistics contribute to efficient machinery utilisation.
5. **Field conditions:** Field conditions, including soil type, moisture content, slope, and obstacles, impact machine efficiency. Proper field preparation, addressing drainage issues, and managing soil compaction can improve machine performance and reduce fuel consumption.
6. **Weather conditions:** Weather conditions, such as temperature, humidity, and precipitation, can influence machinery efficiency. Extreme weather conditions may impact machinery operation, harvesting schedules, and field access. Adapting machine settings and schedules accordingly can help maintain efficiency.
7. **Power source and energy efficiency:** The choice of power source for farm machines, such as diesel, gasoline, electricity, or renewable energy, can impact efficiency. Opting for energy-efficient machines and utilising efficient power sources can help reduce fuel consumption and minimise energy waste.
8. **Proper load management** is crucial for efficient machinery operation. Overloading or underutilising machinery capacities can affect fuel efficiency and overall productivity. Balancing machine loads and optimising work distribution can improve efficiency.
9. **Technology and automation:** Advances in technology and automation have contributed to increased efficiency in farm machinery. Precision Agriculture technologies, GPS guidance systems, telematics, and automation features enable precise operation, reduce overlaps, and optimise inputs, leading to improved efficiency.
10. **Machine age and condition:** Older machinery may have lower efficiency due to outdated technology and wear and tear. Upgrading to newer models with improved design, fuel efficiency, and advanced features can enhance overall machinery and operation efficiency.
11. **Implementation of best practices:** Adhering to industry best practices and adopting efficient operational techniques can boost machinery efficiency. This includes proper calibration of equipment, maintaining appropriate working speeds, and avoiding unnecessary idle time.

Activity 2.17

1. Engage in a brainstorming exercise to generate ideas on the factors that affect the efficiency of farm machines and power during agricultural operations. Use the following leading questions as a guide:
 - a. How do types of soil, their texture and composition affect the performance of a machine?
 - b. How do weather conditions influence the efficiency of machines used in farming?
 - c. How will the maintenance schedule of farm machines impact their efficiency and power output?
 - d. How does the skill level of the operator affect the efficient and effective operation of agricultural machinery?
 - e. In what ways does the design and technology of farm machinery affect its efficiency?
 - f. Does the energy source of the machine affect the machine's efficiency?
 - g. How does the terrain of the farm land influence the efficiency of farm machines?
 - h. How does farming practices enhance or hinder the efficiency of farm machinery?
2. Document your ideas and compare them with your peers for more information on the factors that affect the efficiency of farm machines.
3. Visit a farm site/farm machinery workshop or watch videos/pictures on the use of farm machines and power sources. Make recommendations on how the machines can be used more efficiently.

PRINCIPAL PARTS OF FARM MACHINES AND IMPLEMENTS AND THEIR FUNCTIONS

1. Parts of Farm Machines and Implements and their Functions

- a. **Power source:** Farm machines can be powered by various sources such as engines, electricity or human/animal power. The power source provides the energy required to operate the machine.
- b. **Chassis/Frame:** The chassis form the structural base of the machine, providing support and stability.

- c. **Transmission system:** The transmission system transfers power from the power source to the working components of the machine, enabling the desired operation. It may consist of gears, belts, chains or a hydraulic system depending on the machine.
- d. **Control system:** The control system includes levers, pedals, buttons or electronic controls that allow the operator to manoeuvre and control the machine's operations.
- e. **Cutting /working components:** These parts are specific to the types of farm machines and implements. Examples include blades, discs, teeth or tines. They are responsible for cutting, tilling, sowing, harvesting or other specific tasks required in agricultural operations.
- f. **Wheels/Tyres:** They provide mobility to the machine, allowing it to move across the field. They may vary in size and design depending on the terrain and the machines' purpose.
- g. **Hitching/Attachment mechanism:** Farm implements are often attached to tractors or other machines using hitching systems. These mechanisms ensure a secure connection between the implement and the machine allowing for efficient operation.
- h. **Control panels/Gauges:** Many modern farm machines feature control panels and gauges that provide information about various parameters such as speed, temperature, fuel levels and other relevant data to monitor the machine's performance.

2. Parts of Internal Combustion Engine (Petrol and Diesel Engine)

The major parts of the internal combustion engine and their functions

- a. **Cylinder block:** This is the main structure of the engine and houses the cylinder, pistons and other vital components. It provides support for the combustion chambers.
- b. **Cylinder head:** This is mounted on top of the cylinder block and seals the combustion chambers. It contains intake and exhaust ports, valves and spark plugs.
- c. **Pistons:** They are cylindrical components that fit inside the cylinders. They move up and down within the cylinders, transmitting force generated by the combustion process to the crankshaft.
- d. **Connecting rods:** They connect the pistons to the crankshaft. They convert the linear motion of the pistons into rotational motions of the crankshaft.
- e. **Crankshaft:** This is the vital component that converts the reciprocating motion of the pistons into rotary motion. It transfers power from the pistons to the drivetrain of the engine.

- f. **Camshaft:** It controls the opening and closing of the intake and exhaust valves. It is driven by the crankshaft and operates the valves through a series of lobes.
- g. **Valves:** They regulate the intake of air and fuel mixture and the exhaust of combustion gases. The intake valves allow the mixture to enter the combustion chamber while the exhaust valves enable the expulsion of burned gases.
- h. **Intake and exhaust manifolds:** The intake manifold directs the air-fuel mixture from the carburettor, or fuel injection system, to the intake valves. The exhaust manifold collects and channels the exhaust gases away from the cylinders.
- i. **Fuel system:** The fuel system includes components such as the fuel tank, fuel pump, carburettors and fuel lines. It delivers fuel to the combustion chambers for the combustion process.
- j. **Ignition system:** The ignition system generates a spark to ignite the air-fuel mixture in the combustion chambers. It typically consists of spark plugs, ignition coils and an ignition control module for petrol engines. Diesel engines, however, do not have a traditional ignition system with spark plugs and distributors. Instead, they rely on the high temperature and pressure created during the compression stroke to ignite the fuel.
- k. **Air intake system:** It provides filtered air to the combustion chamber, for mixing with fuel, for diesel engines.
- l. **Turbocharger:** This increases the efficiency of the engine by compressing the incoming air before it enters the combustion chamber in diesel engines, allowing for more fuel to be burned.
- m. **Lubrication system:** This ensures that all moving parts are adequately lubricated to reduce friction and prevent excessive wear. It includes oil pump, oil filter and oil passages.
- n. **Cooling system:** It regulates the engine temperature and prevents overheating. It typically includes a radiator, water pump, thermostat, and coolant passages.
- o. **Exhaust system:** This system guides and expels the combustion gases from the engine, typically through a series of pipes and a muffler.
- p. **Timing belts/chain:** The timing belt or chain synchronizes the rotation of the crankshaft and camshaft, ensuring precise valve timing.



Fig 2.10 Typical petrol engine and some major parts



Fig 2.11 Major parts of a diesel engine



Fig 2.12 Major parts of a diesel engine

3. The Major Parts of a Disc Plough

- a. **Frame:** The frame provides the structural support and stability for the disc plough. It is typically made of strong and durable materials such as steel.
- b. **Discs:** The discs are the cutting components of the disc plough. They are circular blades attached to the frame at a specific angle. The number and size of discs can vary depending on the plough's design.
- c. **Disc Bearings:** Bearings are at the centre of each disc, allowing them to rotate freely. They help reduce friction and provide smooth operation of the discs.
- d. **Disc scrapers:** Disc scrapers are attached near the discs to prevent the accumulation of soil, weeds or debris on the blades. They help maintain the cutting efficiency of the discs.
- e. **Hitching mechanism:** The hitching mechanism allows the disc plough to be attached to a tractor or another pulling vehicle. It ensures a secure connection between the plough and the pulling vehicle.

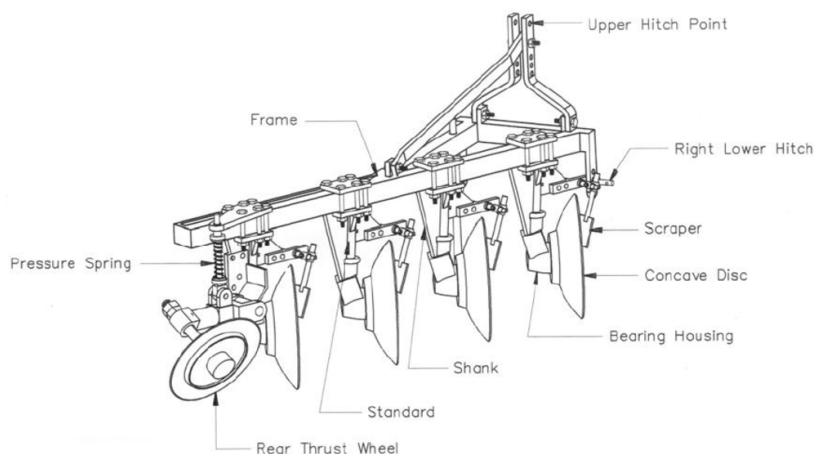

Fig 2.13 A typical labelled disc plough

4. The Major Parts of a Harrow

- a. **Frame:** Like the disc plough, the harrow has a frame that provides support and stability during operation. It is usually made of sturdy materials such as steel.
- b. **Teeth/Tines:** Harrows have teeth or tines that are responsible for loosening and breaking up the soil. The number and arrangement of teeth/tines can vary depending on the harrow type.
- c. **Harrow sections:** The harrow may consist of multiple sections, each containing several teeth/tines. These sections can be adjusted or folded to control the working width of the harrow.

- d. **Harrow bars/drawbars:** Harrow bars or drawbars are used to connect the harrow to the pulling vehicle. They provide a means for attachment and allow for easy manoeuvrability.
- e. **Levelling bar:** Some harrows may feature a levelling bar that helps maintain an even and consistent working depth across the field. It helps achieve a uniform seedbed or prepare the soil for planting.
- f. **Disc gangs/groups:** Discs are arranged in gangs or groups on the disc harrow. A disc gang consists of multiple discs mounted together on a common axle. Gangs can be adjusted to control the working width depth of the harrow.
- g. **Wheels:** Wheels are often attached to harrows to provide stability and control the working depth. They help to regulate the penetration depth of the teeth/tines into the soil.



Fig 2.14 A seed harrow combined with a seed drill

Activity 2.18

1. Visit a farm workshop in your locality or watch documentary/pictures on agricultural implements and machines by clicking [here](#). Identify and describe the major parts of the farm machines and implements by asking the following guiding questions:
 - a. What is the name of the machine/implement?
 - b. What are the major parts of the machine/implement?
 - c. Describe the major parts of the machine/implement
 - d. What are the functions of the major parts?

(Seek assistance from your teacher)
2. Document the major parts of the farm machines and implements and present them to your class for feedback.

Activities 2.19

1. Visit a commercial farm where farm machinery is used in your locality and/or watch a video/picture about parts of farm implements (Click [here](#)). Identify the parts of the disc plough/harrow (seek the assistance of a farm technician). Use the table below to arrange the information on the parts of the farm implements and their uses.

Parts of a disc plough/harrow	Functions

2. Share your findings with among your friends and learn from them too.

STEP-BY-STEP OPERATION OF SOME FARM MACHINES AND IMPLEMENTS

Step-By-Step Operation of Some Farm Machines and Implements in Agricultural Production

a. Mist blower

Step 1: Wear protective gear. Put on appropriate protective clothing including gloves, goggles, and a mask, to ensure your safety during operation.

Step 2: Adjust the settings. Set the desired spraying pattern, droplet size, and spray intensity using the controls provided on the mist blower.

Step 3: Start the mist blower. Turn on the mist blower's engine or power source according to the manufacturer's instructions. Ensure that all safety features are functioning correctly.

Step 4: Calibrate the mister blower to ensure it is dispensing the correct amount of liquid per hectare through the selected nozzle.

Step 5: Prepare the pesticide solution. Dilute the pesticide according to the manufacturer's instructions and ensure proper mixing.

Step 6: Fill the mist blower. Pour the pesticide solution into the tank of the mist blower. Be cautious not to overfill it.

Step 7: Begin spraying. Hold the mist blower nozzle at the correct distance from the target area or crops. Move the mist blower steadily and evenly to ensure even coverage. Pay attention to wind direction to avoid drift. Continue spraying until the desired area is accurately covered.

Step 8: Once finished, turn off the mist blower and clean it thoroughly following proper cleaning and maintenance procedures at the area designed for washing pesticides to prevent environmental contamination.

b. Lawn mower

Step 1: Inspect the lawn mower. Check the lawn mower for any visible damage or mechanical issues. Ensure the cutting blades are sharp and properly attached.

Step 2: Check the fuel and oil levels of the lawn mower and refill as necessary, following the manufacturer's recommendations.

Step 3: Put on appropriate safety gear including gloves, goggles, and closed-toe shoes, before operating the lawn mower.

Step 4: Start the engine. Depending on the type of lawn mower (electric or petrol-powered), follow the manufacturer's instructions to start the engine.

Step 5: Set the cutting height to the desired level using the height adjustment lever or mechanism on the lawn mower. This should be done with the lawn mower switched off.

Step 6: Push or walk behind the lawn mower in straight lines across the lawn. Maintain a consistent speed and overlap each pass slightly to ensure even cutting.

Step 7: Once you have completed mowing the lawn, turn off the engine and allow it to cool down. Clean the mower deck of any grass clippings or debris.

c. Winnowing machine

Step 1: Put on protective clothing including gloves, goggles, and a mask before starting the machine.

Step 2: Prepare the winnowing area. Clear a suitable area for winnowing, preferably outdoors with minimal wind interference.

Step 3: Fill the winnowing machine. Pour the mixed grain and chaff into the winnowing machine's hopper or feeding mechanism.

Step 4: Start the winnowing machine. Switch on the winnowing machine's power source, such as an electric motor or engine, and ensure it is running smoothly.

Step 5: Adjust the settings. Depending on the winnowing machine, you may need to adjust airflow settings or sieve sizes to optimise separation efficiency.

Step 6: Feed the material. Slowly and evenly feed the mixed grain and chaff into the winnowing machine's feeding mechanism or hopper. Ensure a consistent flow for effective separation.

Step 7: Collect separated grains. As the winnowing machine generates airflow, the lighter chaff will be blown away while the heavier grains fall onto a collection area or container. Collect the separated grains for further processing or storage.

Step 8: Clean the winnowing machine. Once the winnowing process is complete, switch off the machine and clean it thoroughly, removing any residual chaff or debris.

Maintaining Farm Implements and Machines

- a. **Read the manufacturer's manual:** Familiarise yourself with the manufacturer's guidelines and recommendations for maintenance procedures, schedules, and specific requirements for each implement or machine. The manual provides essential information and instructions tailored to the model.
- b. **Regular cleaning:** After each use, clean the machine thoroughly. Remove dirt, debris, and crop residues from all surfaces, including the moving parts. Use appropriate cleaning agents and tools while ensuring that electrical components are protected from water and moisture.
- c. **Lubrication:** Lubricate the moving parts of the implements and machines as recommended by the manufacturer. Apply suitable lubricants such as oil or grease to reduce friction and prevent premature wear. Pay attention to pivot points, bearings, chains, and gears, ensuring they are properly lubricated.
- d. **Inspect for wear and damage:** Regularly inspect all components, including blades, belts, chains, tyres and fasteners, for signs of wear, damage or corrosion. Replace any worn or damaged parts promptly to maintain optimal performance and prevent further damage or safety risks.
- e. **Belt and chain tension:** Check the tension of belts and chains regularly. Adjust them to the recommended tension to ensure proper power transmission and prevent slippage or excessive strain on the components.
- f. **Electrical systems:** Inspect electrical wiring, connections, and switches for any signs of worn, damaged, or loose connections. Ensure proper insulation and address any issues promptly to avoid electrical hazards or malfunctions.
- e. **Calibration and adjustment:** Calibrate implements that require it, such as sprayers or seeders, to ensure accurate application rates or proper seed spacing. Adjust settings according to the specific requirements of your operation or crop.
- h. **Storage:** When not in use, store implements and machines in a clean, dry, and protected environment. Consider covering them to shield against dust, moisture, and sunlight. Follow any specific storage instructions provided by the manufacturer.
- i. **Regular maintenance schedule:** Establish a regular maintenance schedule based on the manufacturer's recommendations and the frequency of use. Create a checklist or calendar to keep track of maintenance tasks and ensure they are performed on time.

- j. Safety checks:** Prioritise safety checks, such as inspecting safety guards, shields and emergency stop mechanisms. Ensure that all safety features are in place and functioning correctly to prevent accidents and injuries.
- k. Professional servicing:** For more complex maintenance tasks or repairs, consult qualified professionals or authorised service centres. They have the expertise, tools and access to genuine parts to address more significant maintenance needs and ensure compliance with warranty requirements.

Activity 2.20

(This activity should be carried out only under the supervision.)

1. Listen to a talk by a farm technician and/or watch a video on the step-by-step operations of simple farm machines/implements.
2. Observe the farm technician carefully as he operates a simple farm machine such as knapsack sprayer or mower (the technician will observe all the necessary safety measures).
3. While observing all the safety measures and putting on the appropriate PPEs operate the simple farm machine.

Share your experience of operating the simple farm machine/implement with your peers.

4. Watch videos/pictures to appreciate the operation of complex farm machines and implements such as tractors and combined harvesters.

Caution

Seek assistance from your teacher if you encounter any difficulty in operating the farm machine.

REVIEW QUESTIONS

1. How do measuring tools empower farmers and promote economic development?
2. Why will you advise farmers and sellers of agricultural produce to use standard units of measurement in measuring their produce?
3. A rural farmer who relies on the traditional measuring method such as using 'olonka' or 'Bolga basket' for measuring his farm produce decides to explore opportunities for international trade. What challenges or difficulties might they encounter?
4. Mrs. Doku sowed 250 seeds. If 120 of them germinated into healthy seedlings, what is the germination percentage of the seed? Explain why you will or will not recommend those seeds to the farmer for cultivation.
5.
 - a. Mr. Amponsah, who hatches chicks for poultry farmers in Atebubu, puts 200 fertile eggs in an incubator and 150 of them hatched. Find the hatchability rate of the eggs.
 - b. If he sells a chick for GH¢12, what is the profitability of his business if his production cost is GH¢1200.
6. Most farmers in your community do not appreciate the use of machines in their daily farm activities. As an agricultural student, give five (5) reasons why they should move from a traditional way of farming to mechanised farming.
7. What PPE will you require and use if you are to perform the following farm activities on your school farm? Indicate the reason for using each item.
 - a. Weeding with a mower/slasher.
 - b. Applying herbicides and pesticides using a knapsack sprayer.
 - c. Spreading fertiliser on your farm.
 - d. Harvesting of cocoa/coconut.
 - e. Transporting manure to your farm using a wheelbarrow.
 - f. Giving cattle oral medication.
 - g. Moving cattle from their pen to graze on the field.
 - h. Preparing raised beds for vegetable production.
8. Mrs Allovy owns a big farm in a rural area, growing crops and raising livestock. She currently uses a diesel generator to power her farm operations. However, the generator is old and expensive to maintain. Mrs Allovy wants to explore alternative power sources to reduce costs and environmental impact. Suggest three (3) cost effective and environmentally friendly power sources to Mrs Allovy, give reasons to support your choice

9. Read the following scenarios carefully and answer the questions below:
- a. A farmer, while operating a tractor to plough a field, hits a hidden stump, causing the tractor to jolt suddenly. He loses control and the tractor tips over, trapping him underneath.
 - b. A farm worker enters a grain bin to dislodge some caked grain that is blocking the flow, not wearing appropriate protective gears. Suddenly, the grain collapses engulfing her totally.
 - c. In repairing an irrigation system, the technician accidentally encounters an exposed electrical wire, causing an electric shock.
 - d. A farm worker on a large vegetable farm is responsible for spraying pesticides on the crops. One day, while spraying the pesticides on the crops without wearing the recommended protective gear, they start to feel dizzy and nauseous, with severe headache and a skin irritation.
 - e. A fruit picker spends long hours of the day picking and sorting oranges. Over time, she begins to experience pain and numbness in her wrists and hands, making it difficult for her to continue working.
 - f. Answer the following questions:
 - i. Identify and document the potential hazards and unsafe practices which are in each scenario.
 - ii. Write the consequences and implications of the hazards and unsafe practices in the scenarios.
 - iii. What safety measures could have been in place to prevent this injury?
 - iv. What first aid can be given to the injured person at the farm before taking them to a medical centre for proper treatment.
10. What basic supplies should be included in a first aid box to address the following injuries in agricultural work?
- | | |
|--|--|
| a. Abrasions | f. Abrasions |
| b. Sprains and strains | g. Sprains and strains |
| c. Eye injuries from dust, chemicals or debris | h. Eye injuries from dust, chemicals or debris |
| d. Severe bleeding | i. Severe bleeding |
| e. Traumatic injuries | j. Traumatic injuries |
11. While harvesting crops, a farm worker accidentally cuts his hand with a sickle. In an attempt to stop the profuse bleeding, a co-worker quickly mashes some leaves and puts them on the wound and wraps it with a dirty rag found nearby.
- What potential complications will the injured person experience?
 - Describe the correct first aid response that should have been given to the injured person.

- Discuss the importance of using hygienic and appropriate first aid materials in treating injured persons.
- 12.** You are to conduct a safety audit on a farm that cultivates crops, raises livestock and has workshops for machinery maintenance.
- a.** Identify three potential hazards in each of these areas on the farm.
 - b.** For each hazard, describe specific measures that should be implemented to mitigate the risk and ensure the safety of workers.

Hint

- *In crop production, consider hazards related to equipment use, chemical application and field conditions.*
 - *In livestock production, focus on animal handling, zoonotic diseases and facility safety.*
 - *In the machinery workshop, look at equipment maintenance, storage conditions and electrical safety.*
- 13.** You have been contacted by an investor who wants to venture into farming, on the types of farm machines and power that she should acquire to enable her start farming successfully.
- a.** Suggest at least four (4) farm machines and items of equipment that she can acquire (consider crop production, animal production and fish production).
 - b.** Write a short justification note, on why that machine/item of equipment should be acquired
- 14.** As a newly employed farm technician, suggest at least four (4) ways of ensuring the efficient use of farm machines and power under your care.
- 15.** Due to the high cost of fuel and unstable electricity supply in Ghana, a farmer contacted you for an alternative power source to power his farm equipment and machines. Recommend at least two (2) other sources of power he can use and why you think it will be efficient for his farm production.
- 16.** Differentiate between the ignition system of petrol engine and that of diesel engine.
- 17.** A farmer in your community complains every now and then about his machines not lasting long enough. Advise the farmer on what to do and what not to do to ensure that his machines/implements last longer. Use the following as a guide:
- a.** How to maintain and store the machines.
 - b.** The correct use of machines.
- 18.** Your sister in basic seven wants to know how the knapsack sprayer is being used on the farm. Describe the step-by-step procedure in operating the knapsack to her by providing her with what each step involves.

- 19.** Discuss how the knapsack sprayer can be maintained after use under the following headings:
- a.** Reading manufacturers manual
 - b.** Cleaning/washing
 - c.** Inspect for wear/damaged parts
 - d.** Storage

Extended reading

- https://www.google.com/search?client=firefox-b-d&sca_esv=f977441fd745688c&q=measuring+tools+used+in+farming&tbm=vid&source=lnms&prmd=isvnbmz&sa=X&ved=2ahUKEwjq-bm69-6FAxUXYEEAHQO5CYUQ0pQJegQICRAB&biw=1366&bih=635&dpr=1#
- <https://youtu.be/kL-yr8sxOOA>
- Video on the use of PPEs in farming. Click [here](#)
- Video on farm tools and equipment maintenance.
- Click [here](#) for more videos on farm equipment.
- Videos on farm safety. Click [here](#)
- Agricultural Safety and Health: A Field Guide by Melvin L. Myers
- Dorling, K. (2014). First Aid Manual.
- Krohmer, J.R., Webb, M. and Michael Bond, M.R. (2004). First Aid Manual.
- Murphy, D. J. (1992). Safety and Health for Production Agriculture. American Society of Agricultural and Biological Engineers.

References

- <https://guides.lib.uw.edu>
- National Renewable Energy Laboratory. (2019). Agriculture measuring tools and techniques in horticulture. Kumar D.
- Standardisation and Documentation of Indigenous Measurement Units Used in Agriculture. Shakya N. M. and Sonar R. R. (Journal of Agricultural Informatics. Vol. 3. No. 1. 2012).
- <https://extension.psu.edu/understanding-beef-carcass-yields-and-losses-during-processing>.
- SHS Agriculture Curriculum.
- Eric Amoah (2018) General Agriculture with Text of Practical's and Examinable Questions for West African Senior High Schools. Exotic Publications and Educational Consultancy Ltd. (613- 621)
- Food and Agriculture Organisation (FAO). (2013). Farm mechanisation: A key input for sub-Saharan African smallholders. Rome, Italy: FAO.
- Singh, S. P., & Singh, K. K. (2023). Status and prospects of farm mechanisation for sustainable agriculture. RASSA Journal of Science for Society, 5(1), 35-47.
- Kumah K.A. (2022). Precision agriculture in India, Opportunities and Challenges. Indian Journal of fertilisers, 18(4), 308-331.
- [Occupational Safety and Health Administration](https://www.google.com/url?sa=t&source=web&rct=j&opi=89978449&url=https://www.osha.gov/agricultural-operations/&ved=2ahUKEwiX9d6ahMCGAxUhRUEAHd4uCe0QFnoECBIQAQ&usg=AOvVaw0gakPSaD4zHsh8mdk_JLsR), Agricultural Operations Overview Retrieved from: https://www.google.com/url?sa=t&source=web&rct=j&opi=89978449&url=https://www.osha.gov/agricultural-operations/&ved=2ahUKEwiX9d6ahMCGAxUhRUEAHd4uCe0QFnoECBIQAQ&usg=AOvVaw0gakPSaD4zHsh8mdk_JLsR
- Myers, M. L. (2009). The agricultural safety and health challenge. Resource Magazine, 16(7), 7-9.
- Grandin, T. (1998). Safe Handling of Large Animals (Cattle and Horses). Retrieved from Grandin Safe Handling.
- NIOSH. (2016). Preventing Injuries and Deaths of Workers Who Operate or Work Near Forklifts. Retrieved from [NIOSH](#).
- American Academy of Ophthalmology. (n.d.). First aid for eye emergencies. Retrieved from AAO Eye First Aid.
- Agricultural Machinery - Selection guide and factors affecting. Retrieved from <https://khetigaadi.com/blog/agri-machinery-selection-guide-and-factors-affecting/>.

- Akinsanmi, O. (1975) Certificate Agricultural Science. Longman Singapore Publishers Pte Ltd.
- Dorling, K. (2014). First Aid Manual.
- Kaunsila, B. K. G (2009). Indigenous Agricultural Tools and Equipment of Bangladesh. Retrieved from. <https://books.google.com.gb/books?id=qoY AAAAYAAI>

Acknowledgements



Ghana Education
Service (GES)



List of Contributors

Name	Institution
Dr. Esther Fobi Donkor	UENR, Sunyani
Stephen Owusu-Danso	Saviour SHS
Anthony Mensah	New Konkrompe SHS
Emmanuel Kakpenuba	Wa SHS