

SECTION

5

**BOARDS, BRAKING
SYSTEMS,
MOBILISATION,
WELDING & DIODES**

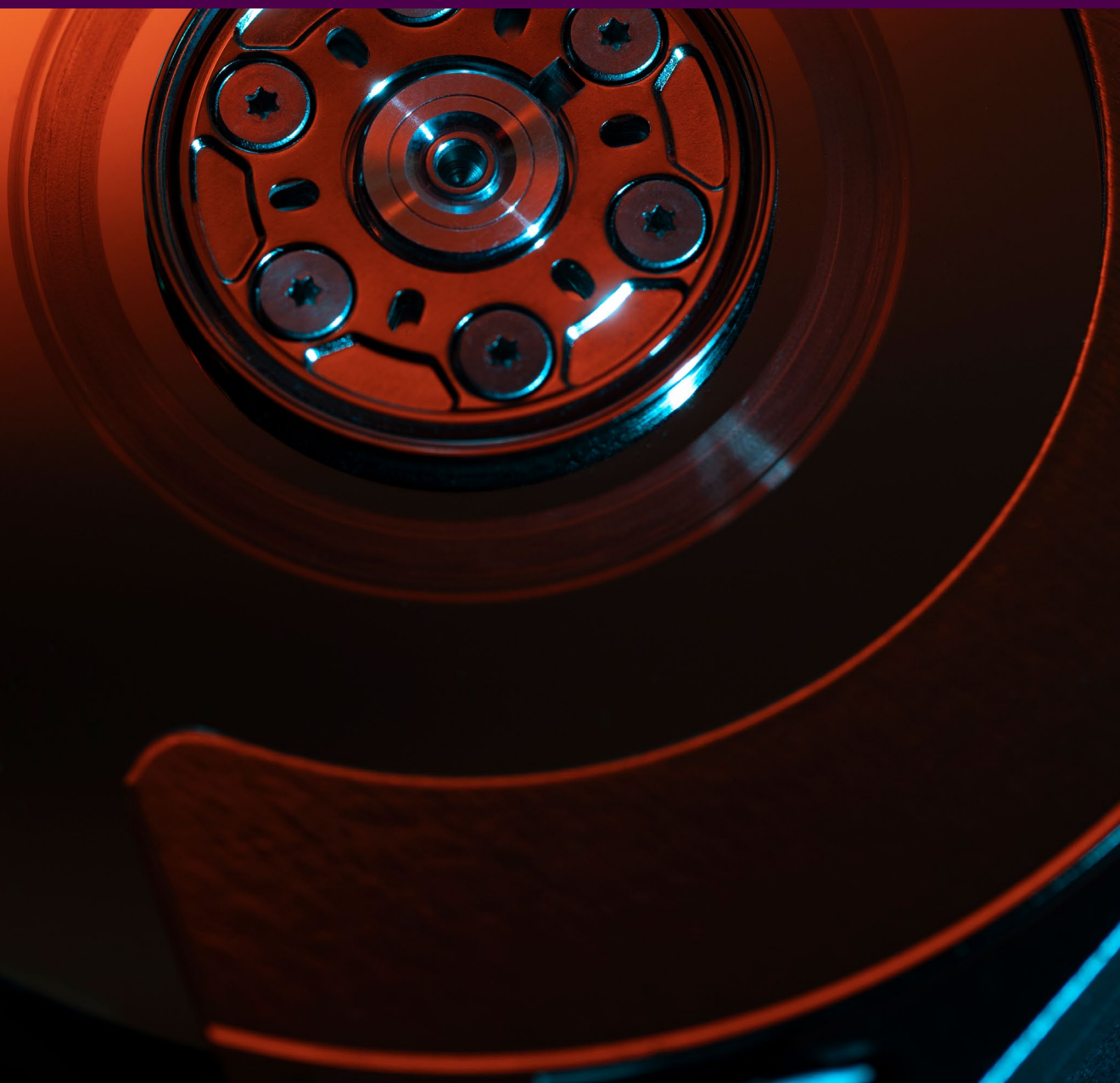

UNIT 1

WOODWORK TECHNOLOGY

Material and Artefacts Production Woodwork Industry in Ghana

INTRODUCTION

Manufactured boards and solid wood are commonly used in construction and furniture making, each with distinct properties. Understanding their advantages and disadvantages is crucial for selecting the right material for specific projects. Manufactured boards provide stability, cost-effectiveness, and consistent quality, while solid wood is prized for its natural beauty and strength. Comparing these materials helps make informed decisions about durability, appearance, and cost.

At the end of this unit, you will be able to:

Discuss the advantages and disadvantages of manufactured boards over solid wood.

Key Ideas

- Manufactured boards are more stable, resisting warping, shrinking, and swelling due to moisture and temperature changes.
- These boards are cost-effective, utilising wood waste and allowing for large-scale production.
- They also come in larger sizes with consistent quality, making them easier to work with for specific projects.
- Manufactured boards may not be as strong or durable as solid wood and can be prone to damage, especially in high-moisture areas. They often require veneers or finishes to enhance their appearance, as their natural look is less appealing.
- Additionally, some manufactured boards release harmful chemicals like formaldehyde, posing health concerns.

ADVANTAGES AND DISADVANTAGES OF MANUFACTURED BOARDS OVER SOLID WOOD

Manufactured boards offer several advantages over solid wood. They are more stable, resisting warping, shrinking, and swelling. They are also cost-effective, using wood waste

and being easier to produce in large quantities. Additionally, they come in larger sizes and offer consistent quality, making them ideal for specific projects.

However, there are disadvantages. Manufactured boards are generally less strong and durable than solid wood and can be more easily damaged, especially in wet conditions. They often require veneers to improve their appearance, as their natural look is less appealing. Some boards also emit harmful chemicals like formaldehyde, posing health risks, as summarised in the table below:

Table 5.1.1: Advantages and Disadvantages of Manufactured Boards Over Solid Wood

No	Advantages	Disadvantages
1	Available in large sizes and uniform thickness covers large areas easily.	Adhesives used in manufacturing can be hazardous when inhaled.
2	Aesthetic flaws like knots can be eliminated, stable-no shrinkage and do not warp.	Adhesives used in manufacturing can also blunt tools quickly
3	Boards required very few finishes.	Many traditional woodworking joints cannot be used and the edges are hard to finish.
4	Some are flexible and easy to bend over formers for laminating.	Boards are prone to absorbing moisture
5	Residue from timber production can be used in producing manufactured boards.	Cutting and sanding some types of boards generates hazardous dust particles.
6	Do not experience seasonal defects such as bowing, twisting or cupping.	Delamination may occur after a long period of use.

Manufactured boards are stable, cost-effective, and uniform, making them practical for many projects. However, they are less durable, less attractive, and may emit chemicals. Understanding these factors helps in choosing the right material based on performance, cost, and aesthetics.

Activity 5.1.1

Scenario:

Your team is designing a new series of eco-friendly office furniture. Present at least two advantages of using manufactured boards instead of solid wood.

Materials Needed:

- Computers/Tablets with Internet Access
- Paper/Notebooks
- Presentation Software (e.g., PowerPoint, Google Slides)
- Projector/Screen

- Markers/Whiteboard
- Pens/Pencils

Activity Guidelines:

1. Discuss why manufactured boards might be better suited for this project compared to solid wood, considering cost, stability, and environmental impact.
2. Share ideas and challenge each other's perspectives to ensure a thorough understanding of the advantages.
3. Research and gather information about the advantages of manufactured boards using digital resources.
4. Use online articles, videos, and comparison charts to collect and analyse data.
5. Each group presents at least two advantages of manufactured boards over solid wood, using evidence from their research.
6. Reflect on the presentations as a team to confirm understanding and discuss the implications for your furniture design.
7. Each group provides a clear explanation of at least two advantages of manufactured boards, supported by research and group discussion.

Activity 5.1.2

Scenario:

Your team is tasked with selecting materials for a new line of furniture. You need to explain at least three advantages of using manufactured boards instead of solid wood.

Materials needed:

- Computers/Tablets with Internet Access
- Paper/Notebook
- Presentation Software (e.g., PowerPoint, Google Slides).
- Projector/Screen
- Markers/Whiteboard
- Pens/Pencils
- Timer

Activity guidelines:

1. Discuss why manufactured boards might be preferable to solid wood. Consider aspects like cost, stability, and environmental impact.
2. Share insights and question each other's ideas to refine your understanding of the advantages.
3. Research the advantages of manufactured boards using digital resources.
4. Use online tools such as articles, videos, and data sheets to gather and analyse information.

5. Each group presents three key advantages of manufactured boards over solid wood, supported by evidence from their research.
6. Reflect on and discuss the presentations to ensure a comprehensive understanding.
7. Each group will explain three advantages of manufactured boards, with their findings supported by research and collaborative discussion.

Activity 5.1.3

Scenario:

Your team is tasked with advising a company on material choices for a new line of furniture. You need to describe two advantages and two disadvantages of using manufactured boards instead of solid wood.

Materials needed:

- Computers/Tablets with Internet Access
- Paper/Notebooks
- Presentation Software (e.g., PowerPoint, Google Slides).
- Projector/Screen
- Markers/Whiteboard
- Pens/Pencils

Activity guidelines:

1. Discuss and evaluate why manufactured boards might have specific advantages and disadvantages compared to solid wood. Consider factors like cost, durability, and appearance.
2. Exchange ideas and question each other's viewpoints to develop a clearer understanding of the materials' pros and cons.
3. Research the advantages and disadvantages of manufactured boards. Each team will focus on one aspect (advantages or disadvantages).
4. Use online resources such as articles, comparison charts, and videos to gather and analyse information.
5. Each group presents their findings, describing two advantages and two disadvantages of manufactured boards compared to solid wood.
6. Share and discuss the presentations with the whole group to deepen understanding and clarify any uncertainties.
7. Each team will deliver a clear summary of two advantages and two disadvantages of manufactured boards over solid wood, supported by evidence from their research.

Extended Reading

- [Oriented Strand Board \(OSB\). APA - The Engineered Wood Association. Retrieved from](#)
- [Walton, J., \(1970\). Woodwork Theory in and Practice \(metric edition\) pages 366-367.](#)

References

1. [Oriented Strand Board \(OSB\). APA - The Engineered Wood Association. Retrieved from](#)
2. [Walton, J., \(1970\). Woodwork Theory in and Practice \(metric edition\).](#)

Review Questions

1. Your company needs to choose between manufactured boards and solid wood for a new furniture project. What are two advantages of using manufactured boards over solid wood?
2. Your team is evaluating materials for a new furniture project. What are four disadvantages of using manufactured boards compared to solid wood?
3. Your company is deciding between manufactured boards and solid wood for a new furniture project. What are two advantages and two disadvantages of using manufactured boards instead of solid wood?
4. What are the main benefits of using manufactured boards instead of solid wood?
5. What are the key drawbacks of manufactured boards compared to solid wood?
6. How do the cost and stability of manufactured boards compare to solid wood?

UNIT 2

AUTOMOTIVE TECHNOLOGY

Introduction to Vehicle Technology

INTRODUCTION

The brake of the vehicle is the most important mechanism that ensures the safety of the occupants, including the driver. In the application of the brakes, kinetic energy, present in the moving vehicle, is absorbed and converted into heat energy to stop the rotation of the wheels. The braking system is designed to reduce the speed of the moving vehicle and eventually bring it to a complete stop. It also ensures that the vehicle is prevented from moving on its own when it is stationary. The car braking system must perform the following fundamental tasks: reduce the speed of the vehicle, bring the vehicle to a stop, prevent unwanted acceleration during downhill driving, and keep the vehicle stationary when it is stopped.

Every functioning vehicle is equipped with two types of brakes. These are primary and secondary brakes. The primary brake (also called service brake or base brake or foundation brake) is the main driver-operated brake of the vehicle. A secondary brake (also called an emergency brake or parking brake) is engaged to prevent the vehicle from rolling or moving when the vehicle is parked on an incline. The service brakes of most modern vehicles are hydraulically operated, which means the braking system uses hydraulic fluid to operate the brake mechanism.

At the end of this unit, you will be able to:

- Evaluate the components of braking systems and state their functions.
- Describe the components of the braking system and state their functions.

Key Ideas

- The braking system is made up of various interconnected parts that work together to convert the driver's foot pressure on the brake pedal into the friction needed to decelerate the wheels.
- Each component plays a unique role, ensuring that the braking process is smooth, reliable, and responsive.
- Understanding the function of the braking system components is key to maintaining vehicle safety and performance.

INTRODUCTION TO AUTOMOTIVE BRAKING SYSTEMS

A **brake** is a device designed to restrain motion by absorbing energy from a moving system usually through friction. It is used to slow or stop a moving vehicle or wheels.

Principle of Operation of Car Brakes

The power generated by the engine is transmitted to the wheels to keep the vehicle moving. The moving vehicle possesses kinetic energy. The value of kinetic energy depends on the weight and speed of the vehicle. However, factors such as road and weather conditions, vehicle's own weight and external load imposed on it, tyre condition, traffic, legal speed limits and air resistance, can affect the speed of the moving vehicle. Car brakes are designed to effectively slow down or stop a moving vehicle by converting the kinetic energy into heat energy through friction generated at the wheels. When the brake pedal is pressed, friction between a moving component (rotor or drum) and a stationary part (calliper or brake shoe) creates resistance which slows down or stops the rotating wheel. The higher the friction, the greater the performance of the brake.

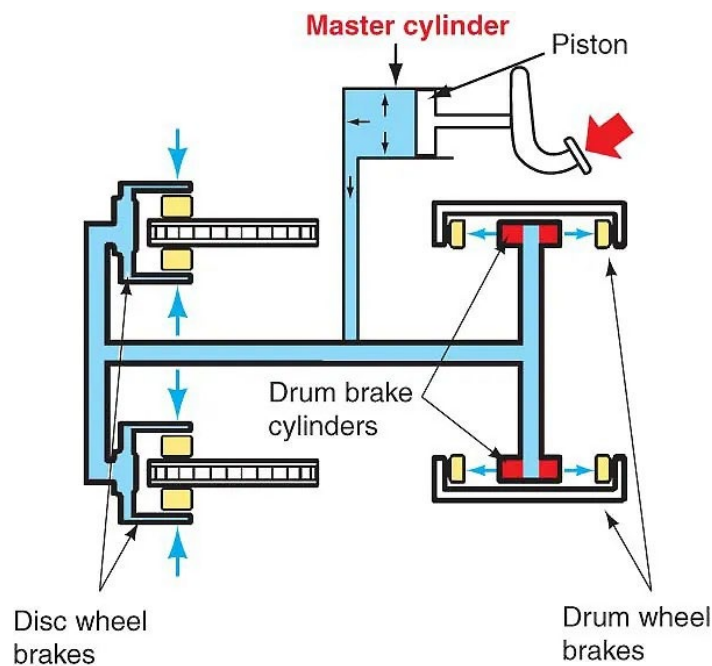

Fig. 5.2.1: A car braking system

Activity 5.2.1: “Give Me a Brake”

Activity Steps

1. Visit: <https://www.scootle.edu.au/ec/viewing/L52/L52/index.html#> to play a game: “Give Me a Brake”.

2. Look for **“Your task”** in the several buttons displayed at the bottom of the screen.
3. Read points 1 to 6 for instructions on how to do the activity.
4. Point 7 will guide you as to how to record your findings after each activity.
5. Answer the questions listed under this point and record your answers using the table provided below. You can also print the table by clicking on the “View” button and selecting “Print”.
6. Compare your answers with your classmates’ answers to identify who had the best scores.
7. Discuss with the larger class the lessons you have learnt from this activity as well as its implications on society.

Table 5.2.1: Template

Speed	Vehicle	Tyres	Road	Weather	Braking distance (m)	Distance from target (m)

NOTE: Tap the other buttons “Information”, “Glossary”, “Challenges” and “Help” for additional information and technical support.

How Car Brakes Work

The modern car uses hydraulic brakes as a stopping medium. A special fluid (hydraulic brake fluid), confined in steel tubing lines, is used to transmit both motion and pressure from the brake pedal to the brake mechanism at the wheels. To stop a moving wheel, the driver exerts a force on the brake pedal. The force on the brake pedal pressurises the brake fluid in the master cylinder.

This hydraulic force is transmitted through steel lines and flexible hoses to a wheel cylinder or calliper at each of the wheels. Hydraulic pressure to each wheel cylinder or calliper is used to force friction materials against the brake drum or rotor. The friction between the stationary friction material and the rotating drum or rotor causes the rotating part to slow down and eventually stop. Since the wheels are attached to the drums or rotors, the wheels of the vehicle also stop rotating.

Activity 5.2.2

How a car brake works

1. Watch the video: ‘How hydraulic brakes work’ at the link below:
<https://www.youtube.com/watch?v=82qBBJ8iwcc>
2. Study the various parts and how they are interconnected.

- Describe how the system operates to provide the braking force needed to stop a moving vehicle. Present your answer on a single page of paper.

Requirements of a Good Braking System

A good braking system must satisfy the following requirements:

- It should be able to stop the moving vehicle in the shortest distance and time, no matter the speed.
- It should be effective on all roads and in all weather conditions.
- The driver's effort on the pedal should be less.
- The braking forces should not affect the arrangement of other systems and parts such as the suspension and steering systems.
- The friction material should not wear out easily.
- There should be no noise or juddering from the brakes when they are applied.
- There should be an independent emergency brake.

Key Components of the Braking System and Their Functions

The conventional braking system is made up of various interconnected parts that work together to convert the driver's foot pressure on the brake pedal into the friction needed to decelerate the wheels. Each component plays a unique role, ensuring that the braking process is smooth, reliable, and responsive. Below is a breakdown of the main parts of a typical braking system and their specific functions.

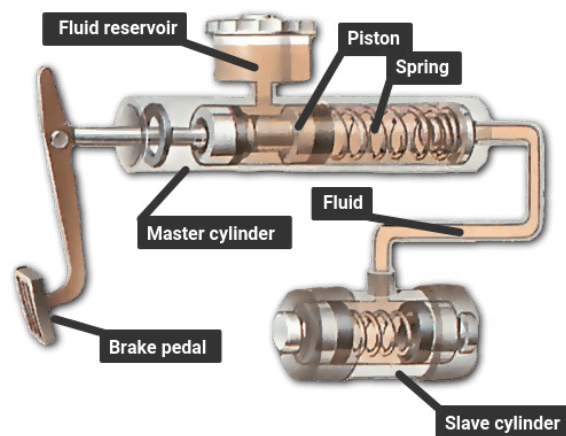

Fig. 5.2.2: The main parts of a typical braking system

Brake Pedal

The brake pedal is the component in a vehicle that the driver presses to initiate the braking action. The driver's effort or force exerted on the pedal is transmitted to the brakes through a linkage that connects the brakes to the pedal. The brake pedal and linkage transmit force

and movement from the driver's foot to the master cylinder. The harder the driver presses the pedal, the greater the braking force.

A brake pedal consists of the arm, pad and pivot attachments. The pedal is connected to a linkage. This linkage transmits force and movement to the master cylinder. The linkage can be as simple as a straight pushrod, hydraulic mechanism, or cable, which is commonly used in parking brakes.

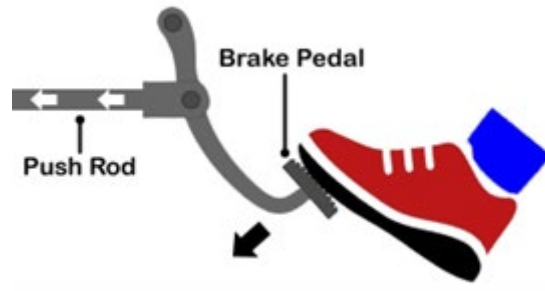

Fig. 5.2.3: The brake pedal

In a manual transmission system, the brake pedal can be identified as the middle pedal whilst it is found on the left in automatic transmission systems. In either case, the brake pedal is operated using the right foot.



Fig. 5.2.4: Identification of the brake pedal in a manual transmission

www.carwale.com

Master Cylinder

The master cylinder converts force from the brake pedal into hydraulic force, pressurising the brake fluid and transmitting it through hydraulic lines to the brake assembly. The master cylinder converts the mechanical force exerted by the driver's foot on the brake pedal into hydraulic pressure. When the brake pedal is depressed, it activates a piston within the master cylinder, pressurising the brake fluid. The pressurised fluid is transmitted through the brake lines to the brake callipers or wheel cylinders at each wheel. The pressurised fluid forces the brake pads or shoes against the brake rotor or drum, resulting in friction, which slows down and stops the vehicle.

The master cylinder uses a piston to multiply hydraulic force such that a minimal pedal pressure generates high pressure in the brake lines, which results in effective braking.



Fig. 5.2.5: A brake master cylinder with fluid reservoir

Fluid Reservoir

The fluid reservoir or tank is a semi-transparent plastic container that stores the brake fluid. It is mostly mounted directly on top of the master cylinder, although some vehicles have the reservoir remotely installed and connected to the master cylinder through flexible hoses. The reservoir ensures constant supply of brake fluid to every part of the hydraulic braking system. It stores sufficient brake fluid which helps to prevent air from getting trapped in the system and to also compensate for fluid losses due to leaks that may occur in the system. When the pedal pressure is released, excess fluid returns into the reservoir. This ensures that the fluid pressure is kept constant and within working limits.

Fluid Lines

The brake fluid lines serve as connections between the various components of the braking system, from the master cylinder to the brake piston or wheel cylinder. They are made of small diameter stainless steel or copper pipes that allow the brake fluid to flow from the master cylinder to the brakes. Flexible, high pressure rubber tubes or hoses connect the metal pipes to the brakes. The flexible hoses allow for free movement between the stationary parts of the vehicle and the wheels during cornering and to also prevent damages and leaks due to the up and down movement of the wheel caused by the suspension system.



Fig. 5.2.6: Brake fluid line

Brake Disc or Rotor

The brake disc or rotor is a flat, circular metal component attached to the wheel hub and rotates with the wheel in disc brake systems. When the brake pedal is pressed, the brake pads clamp onto the rotor, creating friction to slow or stop the wheel's rotation. Rotors need to be smooth and free from warping for effective braking.

Brake Callipers

Brake callipers are used on disc brakes and are responsible for applying the brakes. The callipers are positioned around the circumference of the disc and contain one, two or more pistons which engage brake pads to push against the rotor when the brakes are being applied.



Fig. 5.2.7: Brake calliper

Brake Pads

Brake pads are a part of a disc brake assembly. They consist of a metallic backing plate and a **friction material** bonded to it. They are positioned on either side of the brake disc or rotor. When the brake pedal is pressed, the brake pads push against the rotor, creating the friction necessary to slow or stop the rotating wheel.



Fig. 5.2.8: Brake pads

Brake Drum

The brake drum is a cylindrical component used in drum brake systems. It is installed on the drive axle and rotates with the wheel. When the brakes are applied, the brake shoes move radially outward and press against the inside surface of the drum. The friction created between the brake shoe and the brake drum slows down and stops the rotating wheel. The brake drum is made from a wear resistant cast iron.

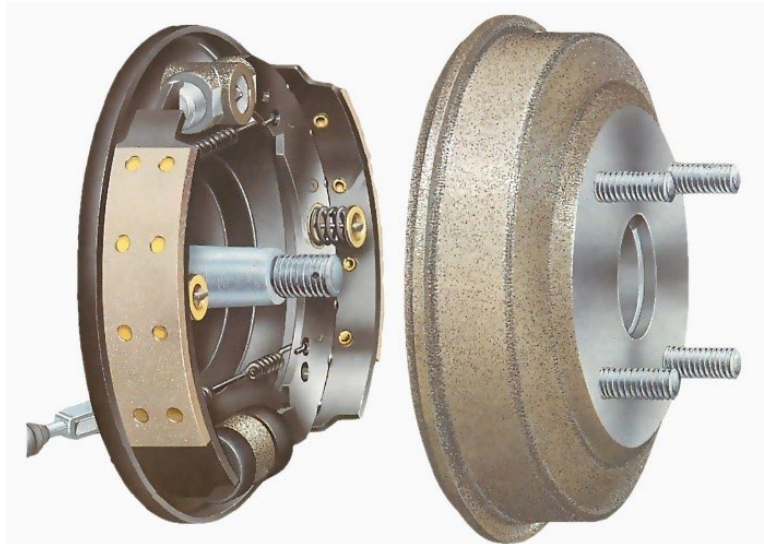

Fig. 5.2.9: Brake drum and shoes assembly

Brake Shoes

Brake shoes are part of a drum brake assembly. They are curved metallic components with a friction material (brake lining) bonded to the outer surface and are enclosed in the brake drum. The brake shoes are secured to the backing plate by a series of springs and levers. The ends rest against the hydraulically operated wheel cylinder. When the brake pedal is pressed, the brake shoes are forced outward by the wheel cylinder pistons, pushing against the inside of the brake drum. The friction generated between the brake shoe and the brake drum helps slow down or stop the rotating wheel.



Fig. 5.2.10: Brake shoes

Brake Lining

The brake lining is a durable, heat-resistant material with a moderate to high coefficient of friction to ensure effective braking performance, safety, and durability. It is attached to the brake pad or brake shoe and makes contact with the rotor or drum when the brakes are applied. It is composed of specialised high-friction material to withstand extreme temperatures and ensure reliable, consistent and efficient braking performance. Lining materials with poor coefficient of friction can easily cause brake fade and potential failure.

Brake lining materials are manufactured with different friction material compounds. They include:

- Non-asbestos organic brake lining
- Low-metallic brake lining
- Semi-metallic brake lining
- Full metallic brake lining
- Ceramic brake lining
- Carbon-carbon composites brake lining

Caution: ensure that masks are worn when working on the brake linings as the dust generated from the brake pads and shoes can be harmful to your respiratory system.

Activity 5.2.3

Properties and constituent materials used in different types of brake linings.

Activity steps

1. Explore the internet and other books to discover the material compounds used in the manufacture of the different types of brake linings and the mechanical characteristics of each type.
2. Use the table format below to record your answer in your exercise book.

Table 5.2.1: Types of brake lining materials: their properties and constituent materials

Brake lining type	Properties	Constituent materials

Activity 5.2.4

Operating the brakes of a car

Materials needed

- A vehicle with functional brakes

Activity steps

1. The teacher will arrange a visit the school's auto workshop or a mechanic shop in the community to observe the various parts of the car braking system and how brakes operate.

CAUTION: Remember to wear your PPE and observe all safety rules at the workshop.

2. Let a friend operate the brake by depressing the brake pedal several times while you observe the movement of the brake mechanism at the wheels.
3. Take turns as you operate the brake pedal while your friend observes the action of the brake mechanism.
4. Observe the features of brake discs and brake drums and explain the effect of friction on them.
5. Write a short report on your visit to the auto workshop emphasising the activity you undertook.

ABS Module

The anti-lock braking system (ABS) is a safety mechanism in the vehicle's braking system, which allows the wheels to maintain traction with the road surface during hard braking. Its main function is to prevent the wheels from locking up and skidding by monitoring the speed of all four wheels and detecting at an early stage if any of the wheels is about to lock up. A good ABS decreases stopping distance on dry and slippery surfaces, and improves vehicle control by ensuring the vehicle remains stable and steerable during braking.



Fig. 5.2.11: Anti-lock braking System symbol

The anti-lock braking system consists of the following parts:

- **Speed sensors:** monitor the rotational speed of each wheel and send the information to the electronic control unit.
- **Electronic Control Unit (ECU) or Controller:** is the central processing unit or computer of the anti-lock braking system. It receives the information from the speed

sensors when a wheel is about to lock up and lose traction during braking. The ECM will then send electrical signals to the hydraulic control unit (HCU) or modulator, which reduces the brake pressure to the specific wheel, preventing it from skidding.

- **Valves:** are installed in the brake lines and regulate brake fluid pressure to the individual brakes. Three positions or settings are designed for the valve. They are open, close, and release. In the open position, full hydraulic pressure is allowed from the brake master cylinder to the brake mechanism; in the close position, the extra pressure is blocked and only a limited amount of pressure is maintained on the brakes; in the release position, the pressure held on the brakes is released.
- **Pump:** restores the pressure to the hydraulic brakes after it has been released by the valve.

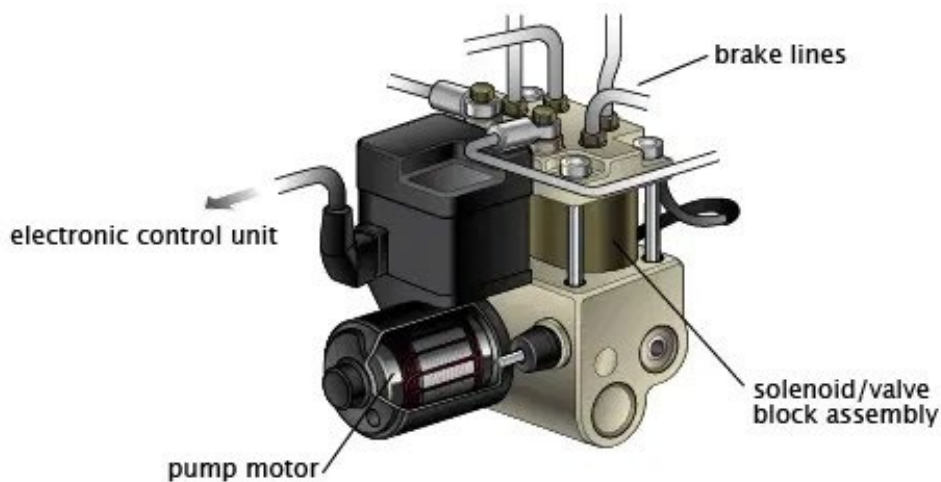

Fig. 5.2.12: an ABS module

Watch the video: “ABS ON vs ABS OFF: What’s Really the Difference?” at the link below.

<https://www.youtube.com/watch?v=mLLYJW-yIIg>

Extended Reading

1. [Anti-lock Braking System \(ABS\) - Main Components And Advantages](#)
2. [How a Car's Braking System Works, its Components and Principles](#)
<https://www.automotive-technology.com/articles/anti-lock-braking-system-main-components-and-advantages#:~:text=There%20are%20five%20major%20components,brake%20fluid%20and%20a%20controller.>
<https://www.firestonecompleteautocare.com/blog/brakes/brake-shoes-vs-brake-pads/>
<https://www.supaquick.com/blog/how-a-cars-braking-system-works-and-its-components-and-principles#:~:text=The%20primary%20principle%20behind%20the,come%20to%20a%20complete%20stop.>
3. [What Are Brake Shoes & How Are They Different From Pads](#)

References

- [Education Services Australia \(2017\). www.scootle.edu.au](#)
- [Halderman, J. D. \(2012\). automotive technology principles, diagnosis, and service \(4th ed.\) Pearson Education, Inc.: Upper Saddle River: New Jersey, USA.](#)
- [Heisler, H. \(2002\). Advanced vehicle technology \(2nd ed.\) Butterworth-Heinemann: Jordan Hill, Oxford.](#)
- [Hiller Automotive <https://www.hillerautomotive.com/post/what-is-the-principle-of-car-brakes>](#)
- [Lawes, John \(2014\). Car brakes: A guide to upgrading, repair and maintenance, The Crowood Press: Marlborough, Wiltshire.](#)
- [Reif, K. \(2014\). Fundamentals of automotive and engine technology. Springer Vieweg: Friedrichshafen, Germany.](#)

Review Questions

1. As part of safety measures, vehicles are required by law to be fitted with an efficient braking system.
 - (a) Sketch the hydraulic braking system with disc brakes at the front and drum brakes at the rear. Use arrows to indicate the directional flow of hydraulic pressure.
 - (b) Briefly explain the basic principles of the vehicle braking system.
2. Sketch any five components of the hydraulic braking system and describe the function of each of them.
3. Early vehicles used drum brakes at the front and rear, then moved towards disc brakes at the front and drum type at the rear. Today, most vehicles use disc brakes at both front and rear.
 - a) Explain why this becoming popular?
 - b) Why must each wheel of the automobile be fitted with a brake?
4. Two drivers have defective brakes on their vehicles. Driver A decides to send their car to the mechanic for servicing. Driver B believes they can still manage the car with a deficient braking system until a time when the brakes can no longer be used before they consider sending the vehicle for repairs. Discuss the social, environmental and economic implications of the actions taken by each of the drivers.
5. The braking force of the vehicle is found in the hydraulic pressure of the brake fluid. Suggest three ways a driver can maintain car brakes to make sure they remain reliable and efficient.

UNIT 3

BUILDING CONSTRUCTION TECHNOLOGY

Pre-Construction Activities

INTRODUCTION

The role of mobilisation in building construction projects is very important for the effective and efficient undertaking of the construction works. Your understanding of mobilisation will enable you to see the relevance of material organisation and decision-making at the right place and time for the success of construction projects. Discussing the reasons for mobilisation will enable you to have a very clear understanding that mobilisation prevents delays of construction projects and also additional costs of construction projects are avoided entirely.

At the end of this unit, you will be able to:

Discuss the reasons for mobilisation.

Key Ideas

- Mobilisation ensures that resources for construction works are well organised.
- Mobilisation also ensures that all the necessary resources are made available at the right places and times.
- Mobilisation prevents delays and additional costs of construction projects.

REASONS FOR MOBILISATION

The critical tasks that confront the contractor as he or she mobilises to the site include testing the soil at the site, site clearance, levelling and other earthworks, eradicating or managing the risk of termites, hoarding off the site, as well as providing the site with the necessary plant and equipment, as well as temporary structures, services and access roads.

1. Basic facilities that the Contractor installs at a construction site during the mobilisation period

During the mobilisation period of a construction project, a contractor typically installs several basic facilities to support the construction activities. These facilities ensure the smooth operation of the project and the welfare of the workers. Key facilities for mobilisation include:

- **Site Office:** A temporary structure where administrative activities, such as site meetings, documentation, and other communications, are handled.
- **Storage Areas:** These are identified areas secured for storing materials, equipment, and tools used in construction, such as cement, steel, and machinery on the sites.
- **Workers Accommodation:** These are temporary shelters which may be provided for workers who need to stay on-site. This decision will usually depend on the location of the project.
- **Sanitary Facilities:** For maintaining hygiene on construction sites, it is necessary that facilities like toilets, showers, and washrooms are provided for the workers.
- **Security Post:** This is usually a checkpoint or guardhouse to monitor access to the construction sites to ensure safety and security of materials and equipment.
- **Water Supply:** A reliable and adequate water source is necessary for construction activities such as concrete mixing and dust control, as well as for the workers' use.
- **Electricity Supply:** At the construction sites provision of temporary electrical installations or generators to power tools, lighting, and other site operations is very important.
- **Access Roads:** In order to promote Internal and temporary roads to facilitate the movement of vehicles and machinery within the sites, provision of access roads to construction sites is very relevant for progress of work.
- **First Aid Station:** In case of emergencies or injuries, a small facility or provision for first aid supplies or first aid box is needed for every construction site.
- **Site Fencing/Hoarding:** Site fencing or hoarding refers barriers that are installed around the perimeter of the construction sites to ensure safety and restrict unauthorised access.

Activity 5.3.1

- Take part in a field trip arranged by your teacher to a construction site and observe the basic facilities that are installed at the site during mobilisation.
- If possible, talk with the site personnel about the importance of the basic facilities on the site during mobilisation.

2. The relevance of activities such as site clearance and termite eradication complete in the mobilisation phase to the building construction process

Site Clearance

Site clearance involves the removal of vegetation, debris, unwanted structures, and obstacles from the construction site. It includes:

- **Preparation for Construction:** Clearing the site provides a clean and level ground, making it easier to lay out building foundations and other infrastructure.
- **Safety:** By removing hazards such as trees, boulders, or waste, site clearance ensures that construction workers operate in a safe environment, reducing the risk of accidents.
- **Efficiency:** A cleared site allows for smoother movement of workers, machinery, and materials, improving the efficiency of construction activities.
- **Accurate Setting Out:** Site clearance ensures that surveyors and engineers can accurately mark and set out building lines, which is essential for constructing the building as per design specifications.
- **Drainage and Erosion Control:** Clearing the site also helps assess natural drainage paths, allowing contractors to plan for appropriate stormwater management systems, which prevent erosion during and after construction.

Termite Eradication

Termite eradication, also known as anti-termite treatment, involves applying chemicals or other treatments to prevent termite infestations. This activity includes:

- **Protection of Building Structures:** Termites can cause significant damage to wooden structures such as doors, windows, formwork, and even roofing. Pre-emptive termite treatment protects these materials, ensuring structural integrity.
- **Long-Term Durability:** Applying anti-termite treatment during the mobilisation phase ensures that the building is less likely to suffer from termite attacks, enhancing its durability and reducing future maintenance costs.
- **Cost Savings:** Preventing termite damage before it occurs avoids costly repairs and potential structural failure in the future, saving both time and resources in the long run.
- **Compliance with Regulations:** In many regions, anti-termite treatment is a regulatory requirement to ensure the longevity and safety of buildings, especially in termite-prone areas.

Activity 5.3.2

- Undertake a detailed study of site activities like site clearance and termite eradication.
- In a group discussion, outline the relevance of activities like site clearance and termite eradication.

3. The activities and facilities provided under mobilisation that can save cost, time and enhance the quality of the entire building project

The activities and facilities provided during the mobilisation phase are essential in setting up a construction site for efficient and effective operations. They play a significant role in

saving costs, reducing construction time, and enhancing the overall quality of the building project. The following activities are those that are undertaken in the majority of works:

Cost Savings

- **Efficient Material and Equipment Management:** Facilities like storage areas and proper site organisation help minimise wastage, theft, or damage to materials and equipment. This reduces the need for replacement or reordering, saving costs on materials.
- **Reduced Rework and Delays:** Proper site clearance, accurate setting out, and termite treatment prevent future complications like foundation shifts or termite damage, which would require expensive repairs. Early investment in quality site preparation reduces the likelihood of costly rework down the line.
- **Economical Use of Labour:** Proper accommodation and facilities for workers ensure that they are readily available and can work more efficiently. This reduces downtime and increases productivity, lowering labor costs.
- **Efficient Utilities:** Installing appropriate water and electricity supplies during mobilisation ensures that resources are used efficiently. It eliminates the need for ad-hoc solutions, which can be expensive or inefficient.

Time Savings

- **Well-Prepared Site for Immediate Construction:** Early activities like site clearance, termite eradication, and the installation of essential utilities (water, electricity) allow for smooth transition into the construction phase. By having a clear, prepared site, the construction team can start laying foundations and building without delays caused by site-related issues.
- **Reduced Interruptions:** By providing essential facilities such as storage for materials and a first aid station, the project is less likely to experience interruptions due to equipment shortages or workplace accidents. On-site amenities ensure that work progresses continuously without unnecessary breaks.
- **Streamlined Communication:** A site office facilitates better communication among project managers, contractors, and workers. This improves coordination and decision-making, reducing delays caused by miscommunication or unclear instructions.

Enhanced Quality

- **Accurate Site Layout and Setting Out:** Activities like site clearance enable precise site surveys and layout, ensuring that construction follows the correct design specifications. This precision minimises construction errors, enhancing the overall quality of the project.
- **Termite Treatment for Longevity:** Treating the site against termites during mobilisation prevents long-term structural damage to wood-based materials. This ensures that the building remains structurally sound over time, enhancing durability and quality.

- **Organised and Safe Environment:** Facilities such as security posts, proper fencing, and sanitary facilities create a safe, organised, and hygienic work environment. This reduces the risk of accidents, improving worker performance and the overall quality of construction work.
- **Quality Control and Monitoring:** A site office provides a centralised space for monitoring, quality checks, and record-keeping throughout the project. Proper supervision and documentation ensure that all works adhere to quality standards and regulatory requirements.

Activity 5.3.3

- i. Undertake individual reading and internet searches on how the activities and facilities provided under mobilisation can save cost, time and enhance the quality of the entire building project.
- ii. During an arranged site visit take pictures of the facilities and activities and make short notes for group discussion

Extended Reading

1. <https://alsyedconstruction.com/why-mobilization-is-crucial-in-construction-projects/>
2. <https://buildbite.com/insights/construction-project-management>
3. <https://buildingradar.com/construction-blog/what-is-mobilization-in-construction-definition-and-importance/#:~:text=Importance%20of%20Mobilization&text=Proper%20mobilization%20ensures%20that%20all,work%20progresses%20according%20to%20schedule.>
4. <https://ccemagazine.com/news/top-6-construction-management-strategies-for-success/>
5. <https://www.constructconnect.com/blog/4-keys-effective-construction-project-management>
6. https://www.designingbuildings.co.uk/wiki/Construction_management:_mobilisation
7. <https://www.viewpoint.com/blog/7-tips-to-achieving-the-best-construction-project-management>

References

1. Austen, A. D., & Neale, R. H. (1984). *Managing construction projects: A Guide to Processes and Procedures*. International Labour Organisation.
2. Cheng, J. C. P., & Kumar, S. (2018). "Mobilizing Resources for Construction Projects: A Systematic Review." *Journal of Construction Engineering and Management*, 144(10), 04018103.
3. Khan, M. A., & Memon, A. H. (2015). "Resource Management in Construction Projects: A Case Study of Pakistan." *International Journal of Project Management*, 33(3), 579-590.
4. Kumar, S., & Kumar, A. (2019). "Resource Mobilisation in Construction Projects: A Review." *International Journal of Construction Management*, 19(4), 305-317.
5. Mokhtar, M. A., & Al-Hussein, M. (2015). "Resource Mobilisation in Construction Projects: A Case Study of the UAE." *Journal of Construction Engineering and Management*, 141(5), 04015002.
6. Ogunlana, S. O., & Promkuntong, K. (1996). "Construction Project Management in Developing Countries: A Case Study of Thailand." *Construction Management and Economics*, 14(3), 233-245.
7. Peng, C. F., Du, H. S., Yin, T. S., Prabhu, J., & Li, H. (2023). *Proceedings of the 2022 7th International Conference on Modern Management and Education Technology (MMET 2022)*. Springer Nature.
8. Zhang, Y., & Li, H. (2010). "Resource Mobilisation in Construction Projects: A Framework." *Construction Innovation*, 10(3), 305-319.

Review Questions:

1. List the basic facilities that the contractor installs at a construction site during mobilisation.
2. Explain the relevance of activities such as site clearance and termite eradication completion in the mobilisation phase to the building construction process.
3. Explain how activities and facilities provided under mobilisation can save cost, time and enhance the quality of the entire building project.

UNIT 4

METAL TECHNOLOGY

Welding Technology

INTRODUCTION

Welding is a critical process in manufacturing, construction, and repair work providing the strengths and durability needed to join metals. Among the various welding techniques, gas welding and electric arc welding are two widely used methods, each with specific applications depending on the nature of the job, materials involved, and the required outcomes.

This unit covers the applications of gas welding and electric arc welding and why it is important for beginners in metalwork technology to have a diverse skill set, cost-effective solutions, portability, precision, heat management capabilities and a strong foundation in welding principles, all of which contribute to successful welding projects. These applications demonstrate the widespread use of gas and electric arc welding across industries for manufacturing, construction, repair and maintenance tasks involving metal joining and fabrication.

At the end of this unit, you will be able to:

Indicate the various applications of gas and electric arc welding.



Key Ideas:



- Gas and electric arc welding are two commonly used methods in metal joining processes.
- Each has specific application, advantages, and limitations, depending on the materials, project size, and working conditions.
- Gas welding is best used for lighter, more detailed work, often in maintenance, repair or artistic applications.
- Electric arc welding is more suitable for industrial application requiring strong, precise works and is widely used in construction, manufacturing, and large-scale fabrication projects.



APPLICATIONS OF GAS WELDING

Gas welding, also known as oxy-fuel welding, is a welding process that uses a combination of fuel gases and oxygen to generate a flame for joining metals. This technique has several applications across various industries due to its versatility and effectiveness. Some of the key applications of gas welding include those shown in Table 1 below:

Table 5.4.1 Types of Application in Gas Welding

Type of Application	Description of type of Application	Safety to Observe when Demonstrating Application	Picture of Demonstrating Application
<p>1. Metal fabrication (Gas welding).</p>	<p>Gas welding is widely used in metal fabrication shops to join different types of metals, including steel, aluminium and copper. It is suitable for both thin and thick metal sections, making it a versatile choice for fabricating metal structures and components.</p>	<ol style="list-style-type: none"> 1. Personal Protective Equipment (PPE) 2. Ventilation 3. Fire prevention 4. Cylinder handling 5. Equipment checks 6. Ignition safety 7. Flashback prevention 8. Work area setup 9. First aid emergency procedures 10. Training and awareness. 	 <p style="text-align: center;">Fig 5.4.1: Gas welding</p>
<p>2. Repair and maintenance with gas welding.</p>	<p>Gas welding is often used for repair and maintenance work in industries such as automotive, aerospace and manufacturing. It allows technicians to repair metal parts, components and equipment on-site or in workshops.</p>	<ol style="list-style-type: none"> 1. Ventilation 2. Fire prevention 3. Gas cylinder handling 4. Lighting torch 5. Work environment 6. Safe shutdown 7. Equipment maintenance 8. Tools/equipment storage 9. Preventive gear 10. Training and awareness 	 <p style="text-align: center;">Fig 5.4.2: Repair and maintenance with gas welding</p>
<p>3. Construction (reinforcement of fabrication with gas welding).</p>	<p>Gas welding is utilised in construction projects for tasks such as welding structural steel beams, joining metal pipes and fabricating metal frameworks for buildings and infrastructure.</p>	<ol style="list-style-type: none"> 1. Personal Protective Equipment (PPE) 2. ventilation 3. Cylinders handling. 4. Fire safety 5. Setup and maintenance 6. Work environment 7. Lighting the torch 8. Emergency preparedness 9. Training and awareness 	 <p style="text-align: center;">Fig 5.4.3: Reinforcement of fabrication with gas welding</p>

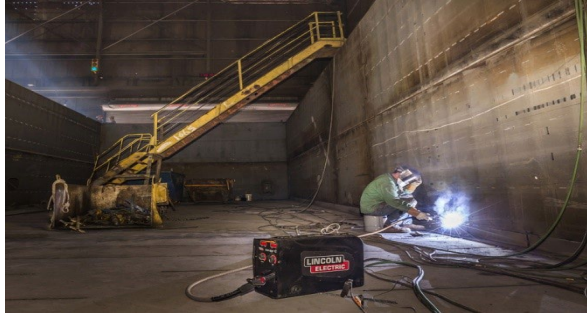
<p>4. Plumbing and Heating, Ventilation and Air Conditioning. (HVAC).</p>	<p>Plumbers and HVAC technicians use gas welding to join copper pipes, fittings and other metal components in plumbing and heating, ventilation and air conditioning systems.</p>	<ol style="list-style-type: none"> 1. Plumbing safety by wearing PPEs. 2. HVAC safety (electrical safety, refrigeration handling, ventilation, heat stress, safe use of ladders, handling ductwork). 3. General safety tips (training and certification, emergency preparedness, worksite cleanliness, proper ventilation). 	 <p>Fig 5.4.4: HVAC</p>
<p>5. Artistic and sculptural work</p>	<p>Gas welding is popular among artists and sculptors for creating metal artwork, sculptures and decorative pieces. It provides precise control over the welding process, allowing artists to achieve intricate designs and shapes.</p>	<ol style="list-style-type: none"> 1. Personal Protective Equipment (PPE) 2. Work on well-ventilated area 3. Check equipment regularly 4. Use the correct gas mixture 5. Secure the workplace 6. Fire safety 7. Handle gas cylinders safely 8. Avoid inhalation of fumes 9. Be aware of surroundings 	 <p>Fig 5.4.5: Artistic and sculptural work</p>
<p>6. Automotive and transportation</p>	<p>Gas welding is used in the automotive industry for repairing vehicle frames, exhaust systems and other metal components. It is also employed in the fabrication of custom vehicles and transportation equipment.</p>	<ol style="list-style-type: none"> 1. Personal Protective Equipment (PPEs) 2. Proper ventilation 3. Cylinder handling and storage. 4. Fire safety 5. Proper equipment setup 6. Safe welding practices 7. First aid preparedness 8. Training and awareness 	 <p>Fig 5.4.6: Automotive and transportation</p>

<p>7. Shipbuilding and marine industries:</p>	<p>Gas welding plays a role in shipbuilding and marine repairs for welding hulls, decks and structural elements of ships and boats.</p>	<ol style="list-style-type: none"> 1. Wear PPE 2. Work area preparation 3. Handling of gas welding equipment 4. Training and awareness 5. Environmental considerations 6. Communication. 	 <p>Fig 5.4.7: Shipbuilding and marine industries</p>
<p>8. Jewellery making with gas welding.</p>	<p>In the jewellery industry, gas welding is used for soldering and joining precious metals like gold, silver and platinum to create intricate jewellery pieces.</p>	<ol style="list-style-type: none"> 1. Proper ventilation 2. Wear PPE 3. Fire safety 4. Gas handling 5. Torch safety 6. Workplace preparation 7. Training and awareness 8. Ergonomics 	 <p>Fig 5.4.8: Jewellery making with gas welding</p>
<p>9. Welding training and education (teaching gas welding school).</p>	<p>Gas welding is commonly taught in welding schools and vocational training programmes as it helps students learn fundamental welding techniques, safety practices and metal joining principles.</p>	<ol style="list-style-type: none"> 1. Qualified instructors 2. proper equipment 3. Use PPE 4. Provide proper ventilation 5. Fire safety 6. Gas cylinder handling 7. Work area organization 8. Emergency procedures 9. Health monitoring 10. First aid readiness 11. Proper training materials 12. Supervision and assessment. 	 <p>Fig 5.4.9: Teaching gas welding school</p>

<p>10. Home and DIY (Do It Yourself). Projects</p>	<p>Gas welding kits are available for home use, allowing DIY enthusiasts and hobbyists to undertake metalworking projects such as metal furniture, sculptures and repairs</p>	<ol style="list-style-type: none"> 1. Wear PPE 2. Ventilation 3. Fire safety 4. Gas cylinder handling 5. Workspace safety 6. Proper use of equipment 7. Training and awareness 8. Hydration and breaks 	
--	---	--	---

Fig 5.4.10 Home and DIY Projects

Note: Observing these safety measures can help prevent accidents and injuries when working on gas welding projects.

APPLICATIONS OF ELECTRIC ARC WELDING

Electric arc welding is a welding process that uses electricity to create an electric arc between an electrode and the base material, generating the heat required to melt and join metals. This welding method has numerous applications across various industries due to its versatility, efficiency and ability to weld a wide range of materials. Some of the key applications of electric arc welding are shown in Table 5.4.2 below:

Table 5.4.2: Types of Application in Electric Arc Welding











Type of Application	Description of type of Application	Safety to Observe when Demonstrating Application	Picture of Demonstrating Application
<ol style="list-style-type: none"> 1. Construction and structural fabrication industry 	<p>Electric arc welding is extensively used in the construction industry for welding structural steel components such as beams, columns and trusses. It is also employed in fabricating bridges, buildings and other infrastructure projects.</p>	<ol style="list-style-type: none"> 1. Wear PPE 2. Fall protection 3. Equipment safety 4. Hazardous materials. 5. Electrical safety 6. Fire safety 7. Ergonomics 8. Site safety 9. Training and communication 10. Emergency preparedness 	

Fig 5.4.11: Electric arc welding in the construction industry.

<p>2. Automotive manufacturing and repair</p>	<p>Electric arc welding is a crucial process in the automotive industry for manufacturing vehicles and welding components such as chassis, frames, exhaust systems and body panels. It is also used for repairing automotive parts and equipment.</p>	<ol style="list-style-type: none"> 1. Wear PPE 2. Work area ventilation 3. Electrical safety 4. Handling materials 5. Safe welding techniques 6. Emergency preparedness 7. Training and certification 8. Training and awareness 	 <p>Fig 5.4.12: Automotive manufacturing and repair</p>
<p>3. Pipelines and Oil/Gas Industry</p>	<p>Electric arc welding is utilised in the construction and maintenance of pipelines for transporting oil, gas and other fluids. It is used to weld pipeline sections, fittings and related infrastructure in the oil and gas industry.</p>	<ol style="list-style-type: none"> 1. pre-job planning and risk assessment 2. Wear PPE 3. Control of flammable materials 4. Proper ventilation 5. Equipment safety 6. Hot work procedures 7. Confined space safety 8. Electrical safety 9. Emergency preparedness 10. Environmental considerations. 	 <p>Fig 5.4.13: Pipelines and Oil/Gas Industry</p>
<p>4. Aerospace and aviation,</p>	<p>Electric arc welding is employed in the aerospace sector for fabricating aircraft components, fuselages, wings, and engine parts. It meets the stringent quality and safety standards required for aviation applications.</p>	<ol style="list-style-type: none"> 1. Wear PPE 2. Ventilation and fume extraction 3. Fire prevention 4. Electrical safety 5. Equipment safety 6. Material handling 7. Hazard communication 8. Training and certification 9. Environmental considerations 10. Health monitoring. 	 <p>Fig 5.4.14: Aerospace and aviation</p>

<p>5. Shipbuilding and marine construction</p>	<p>Arc welding plays a vital role in shipbuilding for welding hulls, decks, bulkheads, and other structural elements of ships and marine vessels. It is also used for repairing and maintaining ships and offshore platforms.</p>	<ol style="list-style-type: none"> 1. Wear PPE 2. Fire and explosion prevention 3. Electrical safety 4. Confined spaces 5. Fume and gas control 6. Handling hazardous materials 7. Hot work permits 8. Emergency preparedness 9. Environmental preparedness 10. Training and competency 	 <p>Fig 5.4.15: Shipbuilding and marine construction</p>
<p>6. Metal manufacturing and fabrication</p>	<p>Arc welding is used in metal fabrication shops to join a wide range of metals, including steel, aluminium, stainless steel and titanium. It is suitable for fabricating metal structures, machinery, equipment and components.</p>	<ol style="list-style-type: none"> 1. Wear PPE 2. Work area safety 3. Equipment safety 4. Electrical safety 5. Fire explosion prevention 6. Handling and disposal of materials 7. Training and awareness 8. Health monitoring 	 <p>Fig 5.4.16: Metal manufacturing and fabrication</p>
<p>7. Railroad and transportation</p>	<p>Electric arc welding is utilised in the railroad industry for welding railway tracks, switches and related infrastructure. It is also used in the manufacturing and maintenance of railcars, locomotives and transportation equipment.</p>	<ol style="list-style-type: none"> 1. Wear PPE 2. Work area safety 3. Electrical safety 4. Welding equipment maintenance 5. Safe welding practices 6. Transportation and handling of materials 7. Environmental considerations 8. Training and supervision 	 <p>Fig 5.4.17: Railroad and transportation</p>

<p>8. Industrial maintenance and repair</p>	<p>Arc welding is used for maintenance and repair work in industrial facilities, including factories, refineries, power plants and processing plants. It helps in repairing equipment, machinery, pipelines and structural components.</p>	<ol style="list-style-type: none"> 1. Wear PPE 2. Electrical safety 3. Ventilation 4. Fire prevention 5. Workplace safety 6. Training and competence 7. Environmental considerations 	 <p>Fig 5.4.18: Industrial maintenance and repair</p>
<p>9. Fabrication of consumer goods</p>	<p>Arc welding is used in the fabrication of consumer goods such as appliances, metal furniture, metal cabinets, metal beds and electronic enclosures. It allows manufacturers to create durable and functional products.</p>	<ol style="list-style-type: none"> 1. Protective gear 2. Ventilation 3. Fire safety 4. Electrical safety 5. Proper safety 6. Workspace 7. Handling and procedures 8. Emergency procedures 	  <p>Fig 5.4.19: Fabrication of consumer goods</p>
<p>10. Welding training and education</p>	<p>Electric arc welding is taught in welding schools, vocational training programmes and apprenticeship courses to train welders in various welding techniques, safety practices and welding procedures.</p>	<ol style="list-style-type: none"> 1. Qualified instructors 2. Protective gear 3. Ventilation 4. Fire safety 5. Training materials 6. Equipment maintenance 7. Emergency procedures 8. First aid 9. Safe practices 10. Supervision 	 <p>Fig 5.4.20: Welding training and education</p>

Note: Observing these safety measures can help prevent accidents and injuries when working on electric arc welding projects.

Conclusions

Both gas and electric arc welding have their unique advantages depending on the project requirements. Gas welding is better suited for smaller, more precise, and mobile applications, whereas electric arc welding is pre-high-volume industrial work requiring stronger and more durable joints. Selecting the right methods depends on material thickness, location, cost, and production scale.

The unit covered the applications of gas and electric arc welding you with the knowledge of the applications of gas-electric arc welding. The assessment requires you to explain and appreciate the applications of gas and electric arc welding. In effect, studying the applications of gas welding and electric arc welding reinforces the concepts and understanding of the welding process. This has also equipped you with valuable knowledge, skills and competencies that are essential for success and practice in the welding industry, engineering professions and other technical fields that rely on welding practitioners.

Activity 5.4.1

The teacher will assign the class into groups for you to undertake a simple project work using gas welding applications. The project is to improve your practical experience, problem-solving skills, technical proficiency, confidence building, portfolio development and creativity and innovation.

Project title: Building a small metal shelf using gas welding applications.

Benefits of project

This project will provide you with practical experience of gas welding while also teaching fundamental skills in metal working and safety.

Project objectives:

1. Understand safety protocols
2. Learn welding techniques
3. Develop measurement and fabrication skills

Materials needed:

- metal rods or flat bars (steel or aluminium).
- gas welding equipment.
- welding rods.
- safety gears.
- measuring tape, angle grinder and clamps.
- metal cutting tools (hacksaw).

Steps:

1. **Design the shelf:**
 - Sketch a simple design for the shelf, including dimensions.

- Prepare a cutting list based on the design

2. Preparation:

- Measure and cut the metal rods or flat bars according to the cutting list.
- Clean the metal surfaces to remove any rust or coating.

Assembly:

- Lay out the metal pieces on a flat surface.
- Use clamps to hold the pieces in place for welding.
- Tack welds the pieces to hold them together before performing the final welds.

3. Welding:

- Wear all safety gear before starting
- Set up the gas welding equipment and adjust the flame to the appropriate settings.
- Perform the welding, ensuring clean, consistent welds along the joints.

4. Finishing:

- Grind down any rough welds and clean up the welds as needed.
- Paint or coat the shelf to prevent rust and improve appearance.

5. Testing:

- Test the stability and strengths of the shelf by placing some weight on it.

Discussion points:

In groups;

- discuss the different types of welds and their applications.
- review safety procedures and common mistakes in gas welding.
- evaluate the finished project and discuss improvements or alternative design.

Activity 5.4.2

Your Technology teacher has assigned you in groups to undertake a simple project work using gas welding applications. The project is to improve your practical experience, problem-solving skills, technical proficiency, confidence building, portfolio development and creativity and innovation.

Project idea/title: Making a metal tool holder using electric arc welding applications.

Benefits of project:

This project will help you practice basic welding skills while creating an artefact functional and useful in the workshop. If you are new to welding, start with simple welds and gradually take on more complex tasks as you gain confidence.

Materials needed:

1. Metal plates (mild steel or any other weldable metal) - for the base and sides.
2. Metal rods - to create hooks or dividers.
3. Welding electrodes - compatible with the metal type
4. Safety gear - welding helmet, gloves, apron, and boots.
5. Grinder - for smoothing edges and finishing welds
6. Measuring tools - ruler, square, and marker.
7. Clamps - to hold pieces of metal in place during welding.

Step-by-step guide**1. Design the tool holder:**

- Sketch a simple design of your tool holder. Decide on your dimensions based on the tools you want to store.
- Common designs include a base plate with several plates or rods to hold tools

2. Prepare the metal pieces:

- Cut the metal plates and rods to the required dimensions using a cutting tool (angle grinder or metal saw).
- Clean the edges of the metal pieces to ensure smooth metal welds.

3. Setup for welding:

- **Arrange the metal pieces in the desired configuration/shape.**
- Use clamps to hold the metal plates together. Make sure everything is aligned properly.

4. Welding process:

- Wear all safety gear before starting
- Start by tacking the pieces of metal together
- Make small welds at key points. This will help keep the structure in place.
- Once tacked, begin welding along the seams. Use the electric arc welder to fuse the metal pieces together. Keep a steady hand and consistent speed to ensure strong, clean welds.
- Weld in a well-ventilated area to avoid inhaling fumes.

5. Finishing touches:

- After welding, use a grinder to smooth out any rough welds or edges.
- Clean the project thoroughly to remove any slag or debris.
- Optionally, you can paint or coat the tool holder to prevent rusting.

6. Final Assembly

- Attach any additional parts, like hooks or dividers, that will hold the specific tools.

- Ensure the tool holder is sturdy and stable.

7. Testing

- Test the tool holder by placing tools on it.
- Make any necessary adjustments/modifications.

Activity 5.4.3

Industrial visit to observe gas welding and arc welding applications.

Background: Your Applied Technology teacher will arrange an industrial visit to a renowned fabrication and welding workshop. The objective of the visit is to gain practical insights into gas welding and arc welding processes, which are crucial activities in the manufacturing and construction industries.

Objectives of visit:

1. **Understanding welding processes:**

The primary goal is to observe and understand the differences between gas welding and arc welding including their principles, equipment used and safety measures.

2. **Practical application:**

To see how these welding techniques are applied in real-world scenarios, particularly in the construction of metal structures, repair work, and manufacturing of metal components.

3. **Safety protocol:**

You will learn about the safety protocols that must be followed during welding operations to prevent accidents and ensure a safe working environment.

4. **Material selection:**

Understanding how different materials behave under gas and arc welding and the criteria for selecting appropriate materials and welding methods for the specific tasks.

Schedule:

1. **INTRODUCTION and safety briefing (30 minutes):**

- Overview of the workshop.
- Safety guidelines and personal protective equipment (PPE) briefing.
- INTRODUCTION to the types of welding processes and their industrial applications.

2. **Gas welding observation (1 hour):**

- Demonstration of oxy-acetylene gas welding
- Explanation of equipment used (cylinders, hoses, regulators, torch).
- Observation of welding on various metals (e.g., steel, aluminium).

- Discussion on the control of flame characteristics, filler material and applications.

3. Arc welding observation (1 hour):

- Observation of shielded metal arc welding (SMAW) and gas metal arc welding (GMAW/MIG).
- Overview of equipment (power source, electrodes holder, ground clamp).
- Observation of welding techniques on different joints and metals.
- Discussions on arc stability, electrode selection and welding parameters.

4. Interactive Q&A Session (30 minutes):

Interaction with welders and workshop assistants to discuss processes, equipment, tools and safety gear and protocols.

Extended Reading

1. <https://autoprotoway.com/automotive-welding/>
2. <https://blog.red-d-arc.com/welding/welding-in-the-oil-and-gas-industry/>
3. https://en.wikipedia.org/wiki/Heating,_ventilation,_and_air_conditioning
4. <https://flynnbros.com/understanding-the-basics-of-structural-welding-in-construction/>
5. <https://medium.com/@weldingforless12/unveiling-the-artistry-exploring-the-fusion-of-welding-and-sculpture-2cb236a827ec>
6. <https://southernjewelrynews.com/latest-news/other-news/creating-jewelry-with-a-welder/>
7. <https://vernlewis.com/welding-in-the-railroad-industry/>
8. <https://www.bottlegases.co.uk/turning-metal-into-artistic-sculptures-with-oxy-fuel-gas/>
9. <https://www.magmaweld.com/welding-training-and-engineering-services-i-210>
10. <https://www.marineinsight.com/naval-architecture/common-welding-methods-weld-defects-shipbuilding-industry/>
11. <https://www.mcrcsafety.com/blog/an-overview-of-welding-in-oil-and-gas-from-the-pipelines-to-steel-platforms-and-ppe-welders-require>
12. <https://www.petrosync.com/blog/welding-repair/>
13. <https://www.rail-fastener.com/types-of-rail-welding-methods-for-ordinary-rail-and-crane-rails.html>
14. <https://www.sciencedirect.com/topics/engineering/gas-welding>
15. <https://www.secindustrial.com/blog/types-of-welding-used-in-the-shipbuilding-industry/>
16. <https://www.shutterstock.com/search/weld-reinforcement>
17. <https://www.thefabricator.com/arcwelding>
18. <https://www.tra-c.com/en/article-2/automated-welding-in-automotive/>
19. <https://www.workforcedevelopment.com/construction/plumber-courses/plumbing.html>

References

- [Amoakohene, S. K., & Sackey, J. K. N. \(2007\). Metalwork Technology \(Motivate series\) Macmillan Education.](#)
- [Fowler, P. & Hershey, M. \(1998\). Craft, Design and Technology. Glasgow, Harper Collins.](#)
- [Garatt, J. \(1994\). Design & Technology. Oxford, Cambridge University Press.](#)
- [Love, G. \(1980\). The Theory & Practice of Metalwork: London & Edinburgh, Longman.](#)
- [Timings, R. L. \(1991\). Mechanical Engineering Craft Theory & Related Subjects: Vol 1&2, Singapore, Longman-Singapore.](#)
- [Willacy, M. D. \(1989\). Craft & Design in Metalwork.](#)

Review Questions

- Q1. You have been tasked with setting up a welding workshop for new trainees in your community.
- ai. Discuss the essential safety procedures that must be implemented for gas welding and arc welding.
 - aii. Discuss how these safety procedures differ between the two welding methods
 - aiii. Identify at least four (4) applications each of gas welding and electric arc welding.
 - bi. Explain with one (1) or more specific example(s) how gas welding can be used in various industries.
 - bii. Describe with one (1) or more specific example(s) how electric arc welding can be used in various industries.
 - biii. Explain at least three (3) applications of electric arc welding in construction projects.
- Q2. You are given the responsibility to weld different types of metals for a construction project.
- ai. Describe how you would choose between gas welding and electric arc welding for various metals such as aluminium, stainless steel, and carbon steel.
 - aii. Describe the factors that will influence your choice of a welding method
 - bi. Explain at least two (2) specific applications each of gas and electric arc welding in shipbuilding and metal fabrication.
 - bii. Describe at least four (4) specific applications of gas welding in the automotive industry.
 - biii. Explain why gas welding should be chosen over electric arc welding in automotive industry application.
- Q3. “Imagine you are required to perform welding in a confined space such as inside a tank or pipeline”.
- ai. Discuss the challenges associated with gas welding in such an environment.
 - aii. Propose strategies to ensure safety and efficiency in welding in a confined space.
 - b. “As a new learner in a practical welding lesson, you noticed defects in the welds produced using both gas and arc welding techniques”.
 - bi. Explain the common types of welding defects that can occur with each method.
 - bii. Explain the causes of these weld defects.
 - biii. Explain how these defects can be prevented or corrected.

UNIT 5**ELECTRICAL AND ELECTRONIC TECHNOLOGY****Electronic Devices and Circuits****INTRODUCTION**

A PN Junction diode is an electronic component which permits one-way current flow only.

It is fundamental to the operation of other components made of semiconductor materials (solid state devices) such as, Zener diodes, Light emitting diodes, Schottky diodes, Varactor diodes and Photo diodes. In this lesson, the formation (structure), principles of operation and applications of the various diodes would be examined.

At the end of this unit, you will be able to:

Employ knowledge of the construction and operation of diodes to design and construct electronic circuits.

Key Ideas

- Identifying the types of diodes referred to.
- Identifying and drawing symbols of the diodes.
- Describing the formation of the diodes
- Explaining the operation of the diodes introduced.
- Explaining the difference between forward and reverse biasing of diodes.
- Stating applications of the diodes alluded to.
- Listing the types of diodes

TYPES OF DIODES AND THEIR APPLICATIONS

There are several types of diodes, each with its own characteristics and applications:

PN Junction Diode

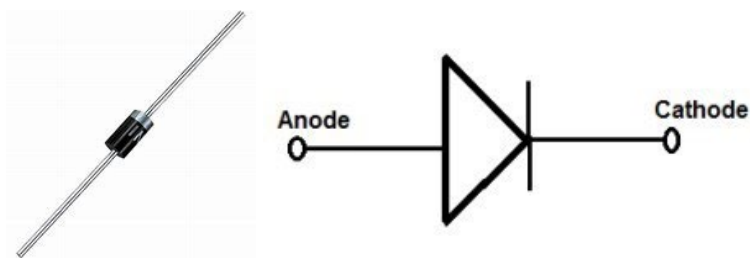

Fig 5.5.1: Picture of a PN junction diode Fig 5.5.2 Symbol of a PN junction diode

Formation of the PN junction diode

- It is manufactured from a single piece of semiconductor material.
- Half of it is doped by P-type impurity and the other half by N-type impurity.
- The plane dividing the two types of semiconductor zones is called Junction.

What happens at the junction?

- **Diffusion**

When the junction is formed, the P-type material has high concentration of holes.

The N-type material has high concentration of free electrons.

There is the tendency of holes to diffuse over to the N-type and electrons to P-type.

This is called carrier diffusion.

- **Equilibrium**

Due to the diffusion, some of the carriers combine to become neutral.

The region near the junction where the neutral atoms are formed is called depletion layer.

(It is washed-out of portable ions)

A potential barrier is developed in this region to prevent further neutralization.

[A potential barrier is the difference in voltage between two points that form an obstacle to the movement of charged particles.]

Due to charge separation by the potential barrier, a voltage known as junction voltage is developed across the junction.

This voltage sets up an electric field which further prevents charges from crossing the depletion layer.

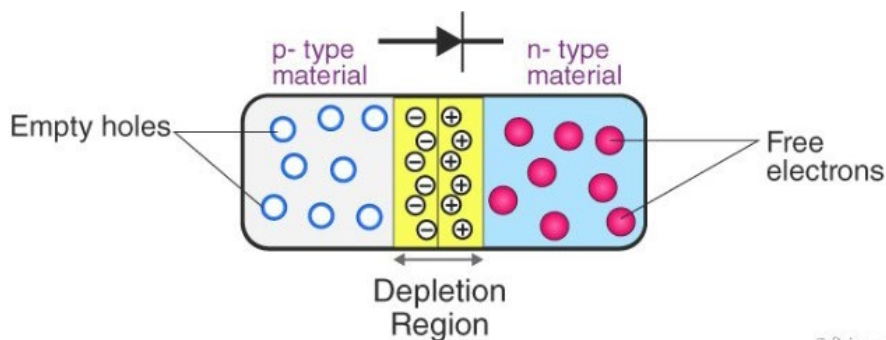

Fig 5.5.3: Depletion region of an unbiased PN junction diode

Biasing

The process of applying an external direct current / voltage to the diode, to make it conduct is known as **biasing**. The p-n junction diode can be biased in two ways;

a. Forward bias

In forward bias an external voltage is applied to the PN junction in such a direction that:

- i. the p-type side is connected to the positive terminal of the battery.
- ii. the N-type side is connected to the negative terminal of the battery.

During this process;

- i. holes from the P-type are repelled by the battery positive terminal towards the junction.
- ii. electrons in the N-type are also repelled simultaneously by the negative terminal of the battery towards the junction.

Under this condition;

- i. the potential barrier is reduced,
- ii. junction resistance becomes almost zero
- iii. depletion layer narrows
- iv. appreciable current flows.

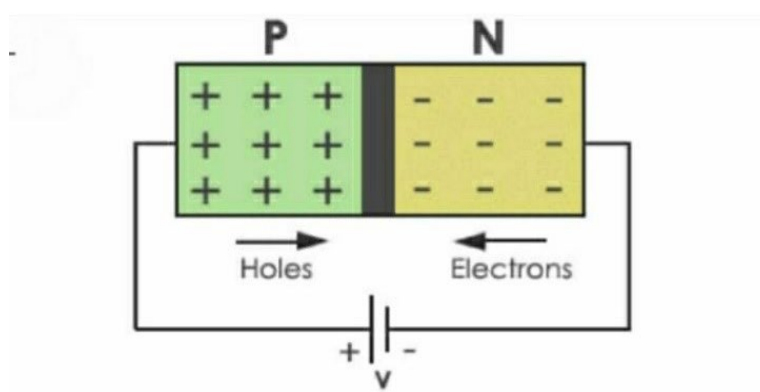

Fig 5.5.4: forward-biased PN junction diode

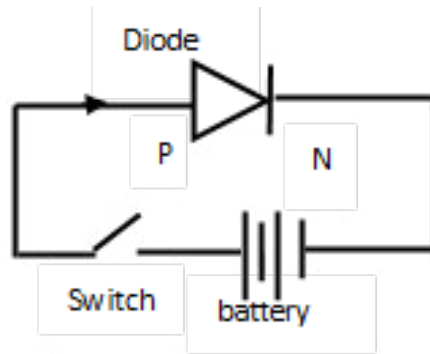

Fig 5.5.5: forward-biased PN junction diode.

b. Reverse bias

In reverse bias an external voltage is applied to the PN junction in such a direction that;

- i. the positive terminal of the battery is connected to the N- type side.
- ii. the negative terminal of the battery is connected to the P-type side,

During this process, both electrons in the N-type and holes in the P-type are pulled away from the junction.

Under this condition;

- i. the potential barrier is increased, [depletion layer widens.]
- ii. the flow of carriers across junction is prevented,
- iii. a high resistance path is established
- iv. only leakage or very little current flows.

This state is called reverse bias.

A PN Junction diode can be enclosed in a protective housing, usually glass, plastic or metal.

It exists in only two possible states, either ON or OFF at a given time.

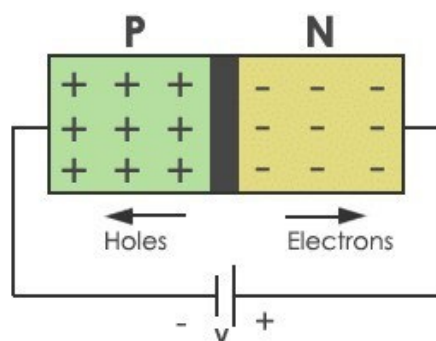

Fig 5.5.6: Reverse-biased PN junction diode

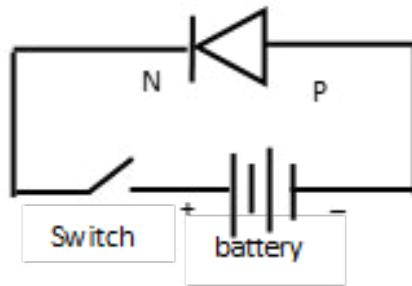

Fig 5.5.7: reverse-biased PN junction diode

Unidirectional property of the diode

The process of converting alternating current (a.c) voltage into direct current (d.c) voltage is known as rectification.

In one full cycle of the input a.c wave; during the positive half-cycle, the diode is forward-biased, it conducts and current flows.

During the negative input half-cycle, the diode is reverse-biased, the negative input half-cycle is suppressed and the diode does not conduct, but a very little (leakage) current flows.

In this process, the diode is used as a rectifier to change alternating current (a.c) to pulsating direct current (d.c). The output voltage is a pulsating d.c wave.

The diode permits the flow of current in only one direction.

The plate at the end of the arrow reminds us that, the diode stops the current flow from opposite direction.

Light Emitting Diode (Led)

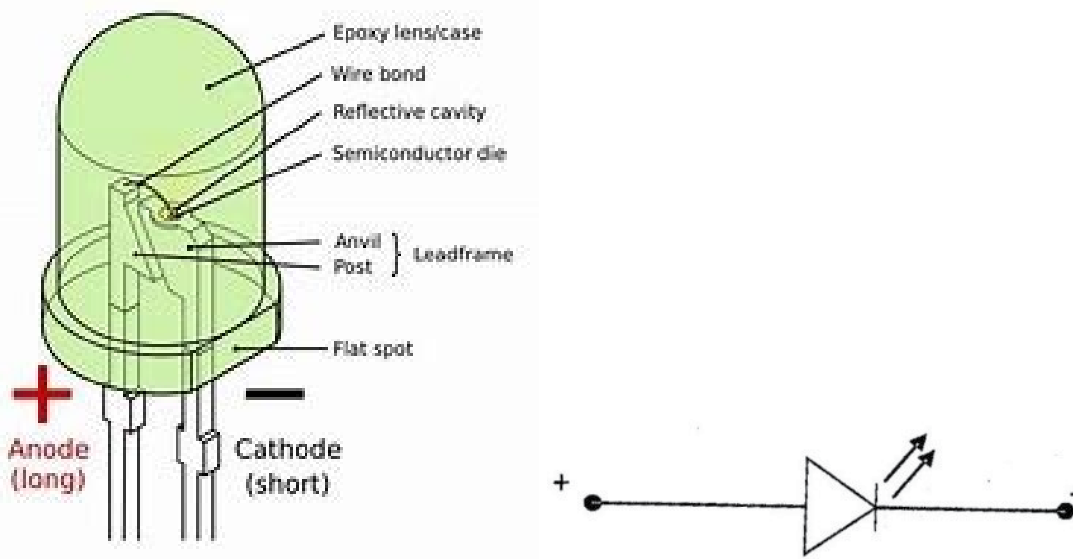

Fig 5.5.8: Visible light emitting diode Fig 5.5.9 Light emitting diode

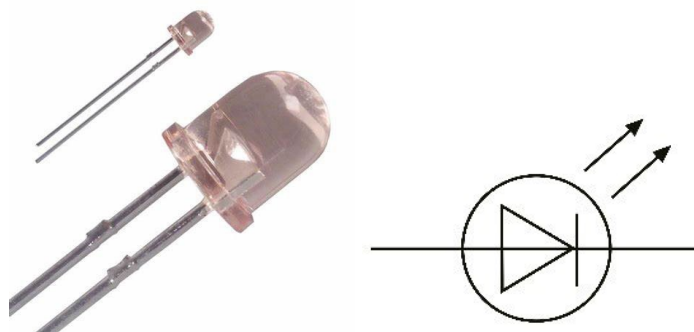

Fig 5.5.10: Infra-red light emitting diode **Fig 5.5.11** Light emitting diode

Semiconductor material

The Light Emitting Diode (LED) is made up of elements such as Gallium, Arsenic or Phosphorous, and compounds like

- i. Aluminum – Gallium – Arsenide (AlGaAs)
- ii. Gallium – Arsenide – Phosphide (GaAsP),
- iii. Gallium -Phosphide (GaP)
- iv. Gallium -Arsenide (GaAs).

PN junction

An LED is a specially made-up semiconductor PN junction diode that emits monochromatic (a single-colour) light when forward-biased.

Electron movement

Electrons are at a higher conduction band in the N-side, and holes are in a lower conduction band in the P-side. When the PN junction is forward biased, free electrons from the N-side cross the junction and fall into the holes in the P-side.

Recombination

As the free electrons fall from a higher energy to a lower energy level, they radiate energy.

The LED emits light spontaneously as a result of the recombination of electron and holes when forward- biased.

Light emission

In the LED materials, a greater percentage of energy during the recombination is given up as light.

It emits light to give up the difference in energy.

The energy gap of the material used to construct an LED determines whether the emitted light is invisible or visible and of what colour.

LEDs can be produced that can give out red, green, yellow, blue or orange light or even the infrared (invisible radiations).

The forward-bias across the diode must exceed a threshold level before it starts conducting.

Colour control

The colour of light emitted by an LED depends upon a number of factors such as the type of material used to make the LED and the energy band gap.

The energy gap is indicative of how much energy each electron needs to cross the junction barrier.

- i. A smaller band energy gap means that fairly low energy electrons can cross the barrier, then, the emitted radiation is infra-red (invisible) or red light.
- ii. If the band gap is large only highly energetic electrons can cross the barrier. The LED then emits blue or violet light.

Visible light LEDs are made of:

- i. GaP - (Gallium Phosphide) and give off red or green light;
- ii. GaAsP – Gallium Arsenide Phosphide and give off red or yellow light.

Application

L.E.D.s that emit light in the infra-red region are widely used for remote controls of TV, CD players, burglar alarms and other sensing applications.

LEDs that produce visible radiation are useful in instrumentation, calculators, advertisement displays etc.

Zener Diode

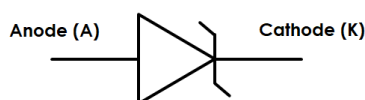

Fig 5.5.12: Zener diode Fig 5.5.13 Symbol of a Zener diode

Formation

Zener diode is a more heavily doped Silicon or Germanium PN junction.

The effect of the heavy doping is to yield:

- i. a smaller breakdown voltage,
- ii. a narrower depletion layer
- iii. larger power rating.

Operation

Zener biasing

For proper working with the zener diode in any circuit, it must be connected in **Reverse-bias**.

Zener breakdown

Zener diode is designed to operate in the breakdown region. When a zener diode breaks down, two effects occur they are:

- i. zener breakdown that occurs at a reverse voltage less than 6V.
- ii. avalanche breakdown that occurs at a reverse voltage more than 6V.

In zener breakdown, reverse- bias voltage is applied, and a strong electric field pulls the electrons out of the covalent bonds. This results in an extremely large number of electron-hole pairs being formed and increases the reverse current sharply.

Avalanche breakdown

When a higher reverse voltage is applied, it accelerates the minority carriers in the depletion region. When these carriers attain sufficient kinetic energy, they disrupt the covalent bond and the carriers cause reverse current to increase sharply.

Zener diode as a s stabiliser (*Stable voltage*)

Zener diode can be used as a constant voltage source (voltage's stabiliser). Once input voltage increases and the voltage across the load becomes more than the zener rated voltage, the zener diode starts operating in the breakdown region.

During this operation, the zener voltage, (V_z) remains constant. The output (zener) voltage should not, within limits, be affected by:

- i. differing load current,
- ii. changes in the supply voltage.

Voltage regulation

Voltage regulation is a measure of a zener diode's ability to maintain a constant output voltage even if different loads are connected across it. Using a zener diode in reverse bias and in series with a resistor makes a simple voltage regulator.

Over voltage protection

Zener diodes are used as voltage limiters and for meter protection against damage from accidental voltage spikes or application of excessive voltage.

Schottky Diode

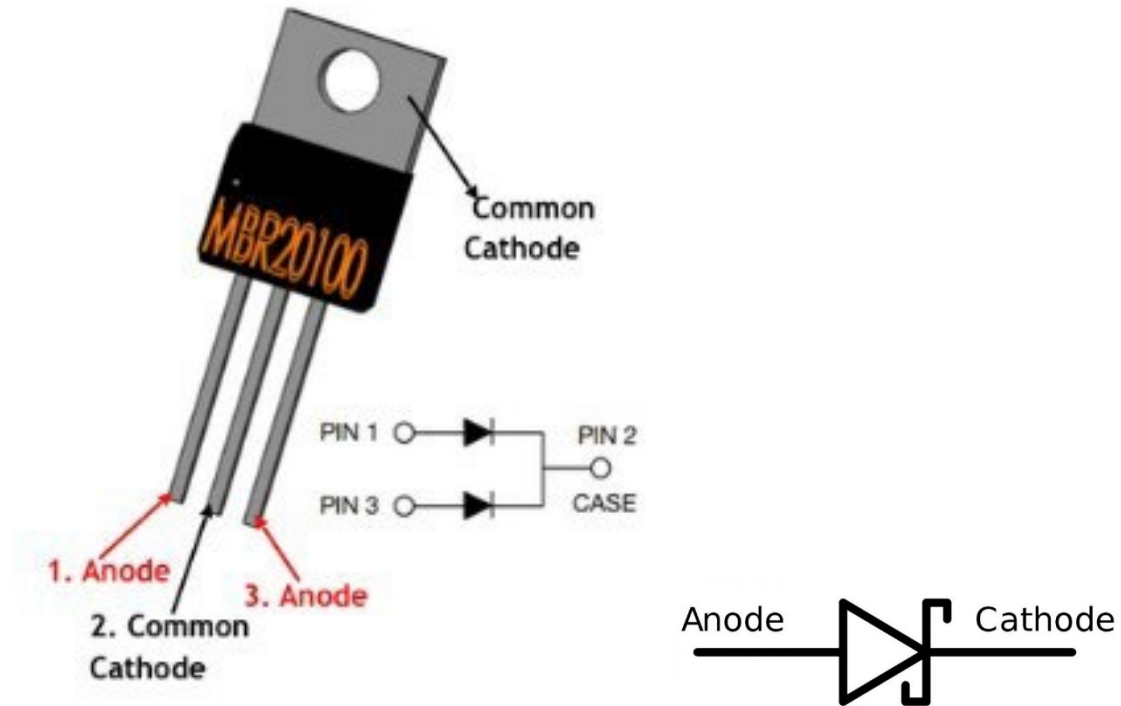

Fig 5.5.14: Schottky Diode Fig 5.5.15 Symbol Schottky Diode

Picture of a Schottky diode Symbol of a Schottky diode

Metal-semiconductor junction

A *Schottky diode* is a metal-semiconductor junction, that has no depletion region.

Barrier formation

The junction is made between a metal (such as gold, silver, aluminium, tungsten etc,) and a lightly doped (usually N-type) Silicon (or Gallium Arsenide).

It is a unipolar device because it has electrons as majority carriers on both sides of the junction.

It has neither holes (minority) carriers available in the metal, nor depletion layer present.

Operation

i. Unbiased mode

When the diode is unbiased, electrons on the N-side have lower energy levels than electrons in the metal. They cannot surmount the junction barrier (called Schottky barrier) for going over to the metal.

ii. Forward bias

When the diode is forward biased, conduction electrons on the N-side gain enough energy to cross the junction and enter the metal. These electrons plunge into the metal with a very large energy, so, it is often referred to as hot-carrier diode.

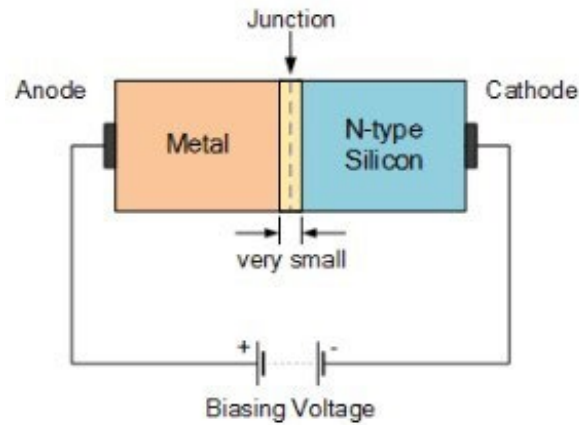

Fig 5.5.16: The structure of a Schottky diode, forward-biased.

iii. Reverse bias

When the polarity of the diode is reversed, the Schottky barrier widens, and the electrons are incapable of crossing into the metal.

Low forward voltage drops

The Schottky barrier is narrower, so the forward voltage drop is smaller in the Schottky diode and this makes it a fast switching and low power loss device.

Application

It is commonly used in switching power supplies that operate at frequencies of 20 GHz, communication receivers and radar, clamping and clipping circuits, computer gating, mixing and detecting networks used in communication systems.

The Schottky diode can easily rectify signals of frequencies exceeding 300 MHz and switch from ON to OFF much faster than a bipolar diode.

Varactor Diode

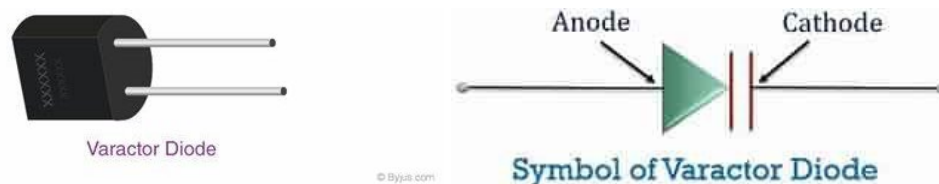

Fig 5.5.17: Picture of a Varactor diode

PN junction

Varactor diode is a semiconductor and voltage-dependent variable capacitor diode.

Alternatively, it is known as varicap or voltage-variable (VVC) diode.

The PN junction is a region of high resistivity, packed- in between two regions of relatively low resistivity. The varactor diode is a specially manufactured reverse bias PN junction.

Depletion region

In the varactor diode, the positive and negative charges on each side of the junction are separated by depletion region.

The depletion region acts as a dielectric (insulation) medium between the two conducting (P-type and N-type) plates.

This is analogous to a capacitor consisting of two conductors separated by an insulator or dielectric.

Voltage-depletion capacitance

There exists a certain amount of capacitance of the junction referred to as depletion layer capacitance or simply junction capacitance.

The diode is operated with reverse-bias. The effect of the bias on the junction makes the depletion layer act like a variable thickness of dielectric (insulation) medium.

The depletion layer capacitor is proportional to the junction area and inversely proportional to the width of the depletion region.

- i. As reverse-bias voltage is increased, the depletion layer widens, the junction capacitance is therefore minimum (reduces).
- ii. As the reverse-bias voltage is reduced, the junction capacitance is greatest (maximum).

Its mode of operation depends on the transition (changing) capacitance. The junction capacitance is therefore least with large reverse-bias and greatest with small reverse bias. When a forward bias voltage is applied the depletion layer narrows and increases the junction capacitance.

The widening of the depletion layer is therefore a function of the junction voltage. Capacitive effects are exhibited by the p-n junction when they are either forward-biased or reverse-biased.

Application in tuneable circuits

Varactor tuning is widely used at Very high frequency (VHF) and Ultra high frequency (UHF), where only small variations of capacitance are needed and where Automatic Frequency Control (AFC) circuits are essential in setting local oscillator (Lo) such as (voltage controlled oscillator) signal in radio, television and mobile phones.

Frequency modulation and filters

Varactor diode is suitable for use in high frequency generators, frequency converters or mixers, FM modulators, adjustable band-pass filter and Automatic frequency control devices.

Photo Diode

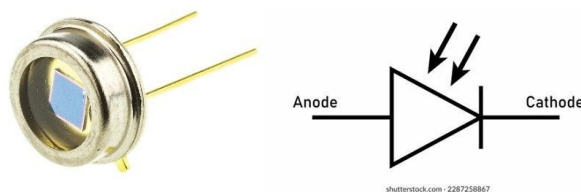

Fig 5.5.18 Photo diode Fig 5.5.19 Symbol of a Photo diode

PN junction

Photo diode is a semiconductor, light sensitive PN-junction specially designed to work as light-detector.

It is constructed from a single crystal silicon wafer of high purity.

It consists of an N-type silicon, and a thin P-layer.

The PN junction is formed at the (plane) interface of the N-type silicon and the P-layer.

Window layer

The thickness of the P-layer is decided by the wavelength of the radiation to be detected.

For maximum activity, a lens is placed on the junction to focus the incident light

When the light bombards the P-active area, it dislodges valence electrons. Electron-hole pairs are produced and the reverse current in the diode increases.

Metal contact

A small metal contact at the front surface is the anode of the diode. The entire back is coated with a metal contact and also represents the cathode of the diode.

Packing

The photo diode is contained in a transparent material. When illuminated by light, a reverse current flow. The current is very small, but the speed of response is rapid.

Reverse bias operation

The diode is operated with reverse bias. Near the PN junction the silicon becomes depleted of electrical charges. This is known as the depletion region.

The depth of the depletion region can be varied by varying the reverse -bias applied to the diode.

The change in the output voltage is proportional to the incident light.

Application

Industries, process control and automation, instrumentation, communication, cameras, intrusion alarms, light-wave communicators.

Silicon Controlled Rectifier (SCR)

The SCR is a four -layer, three terminal semi-conductor and a uni-directional device.

The terminals are Anode, Cathode and Gate.

The anode and cathode layers are heavily doped, while the gates are slightly doped.

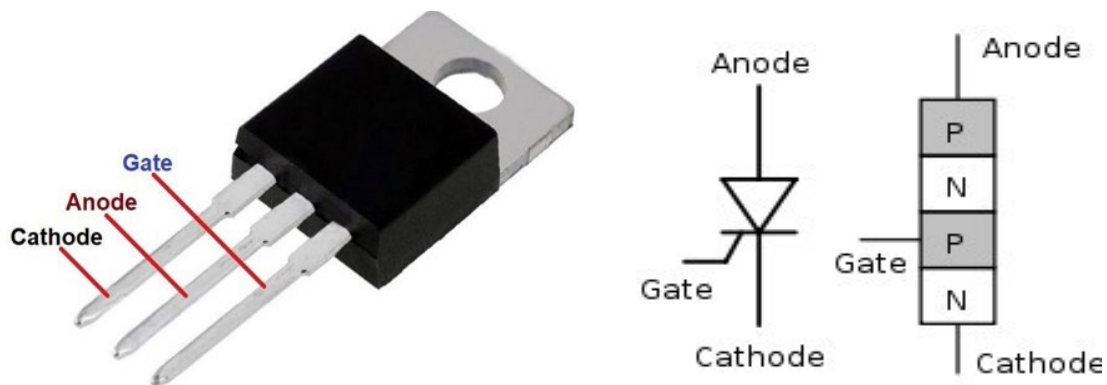

Fig 5.5.19: SCR Fig 5.5.20 PNPN structure of SCR

Modes of operation in SCR

i. On-State (Conducting mode)

When the forward triggering voltage is applied across Anode and Cathode, Junctions J_1 and J_3 are forward-biased and conduct, but J_2 is reverse-biased and does not conduct.

Junction J_2 therefore blocks current flow and only leakage (very little) current flows.

When the anode voltage is increased, breakover voltage is reached, and J_2 breaks down and the SCR switches suddenly to a high conducting state.

The potential at which the breakdown occurs is known as breaking potential or firing potential

The gate terminal is used to control the turn -ON of the SCR. Once the SCR is ON, the gate loses control.

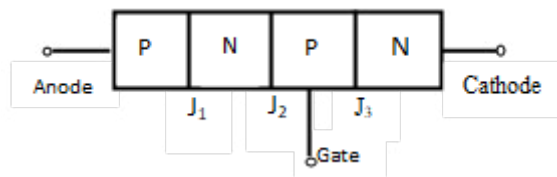

Fig 5.5.21: A diagram of the junctions in SCR

ii. Control of SCR

To switch an SCR off, the anode current must be reduced below a level called **holding current**.

The **holding current** is the minimum anode current that will maintain the SCR in conduction.

The minimum current at which the gate voltage can be removed and the SCR still remain in the conducting state is called **latching current**.

iii. Off state (forward blocking mode)

When reverse voltage is applied, J_1 and J_3 are reverse - biased, J_2 is forward biased, no current flows through the SCR. When V is increased the SCR will be destroyed.

Application of SCR

They are regulated power supplies, static switches, battery chargers, motor controls, heater controls, relay control and inverters.

Activity 5.5.1

1. Describe the basic working principle of a PN junction diode.
 - i. State what the PN junction diode is made of.
 - ii. Clarify what happens when the P-type and N-type parts are brought together.
 - iii. State how carrier diffusion is stopped.
 - iv. What name is given to the space that develops between the two types of semiconductors?
 - v. Pinpoint what takes place at the depletion layer?
 - vi. Clarify what must be done for the diode to conduct current.
 - vii. List the two methods of connection adopted in an attempt to make the diode conduct current.
 - viii. Explain briefly how the connections are done.
 - ix. Which of the connections allow more current to flow through the diode?
 - x. Itemize what happens when a PN junction diode is forward-biased.

- xi. State what happens to the diode when the diode terminals are reverse-connected to the supply?
- xii. Justify why the diode is a uni-directional diode.

Activity 5.5.2

1. How does a Zener diode differ from a regular PN junction diode?
 - i. What is the composition of zener diode and a PN junction diode?
 - ii. Which of these two diodes has a larger depletion region?
 - iii. What accounts for the difference in the sizes of the depletion regions?
 - iv. What mode of connection is used to make the zener diode conduct current?
 - v. State the mode of connection used to make a regular PN junction diode conduct current.
 - vi. Does the same mode of connection of the zener diode, also make the regular PN junction diode conduct?
 - vii. Which of the two diodes is used at the input section or at the output section of a circuit?
 - viii. Which of the diodes work as a rectifier or as a voltage regulator?
 - ix. Identify the difference in operation of the zener diode and the PN junction diode.

Activity 5.5.3

1. How does a light-emitting diode (LED) work and what causes it to emit light?
 - i. List the different types of compounds that are used in the formation of the light emitting diode LED.
 - ii. State which of the charge carriers are in a higher conduction band and which are in the lower conduction band of the LED?
 - iii. List three movements that happen to the charge carriers when the LED is forward biased.
 - iv. Into what form of energy is a large percentage of the energy difference between the charges converted?
 - v. State the two frequencies at which light is produced by the LED.
 - vi. State what decides the kind of light produced.

Activity 5.5.4

1. Discuss the operation of a photodiode and its use in light detection applications.
 - i. Identify the materials used in the formation of the photo diode.
 - ii. State how the photo diode is able to produce electric current.
 - iii. How is the photo diode biased into conduction?
 - iv. State how the depth of the depletion region is varied.
 - v. State what determines the change in output voltage of the diode.
 - vi. List four light -detecting domestic and industrial applications of the photo diode.

Extended Reading

- <https://weobserved.com/wp-content/uploads/2019/05/led.png>
- www.nature.com/articles/d42473-023-00450-9
- https://en.wikipedia.org/wiki/CT_scan#:~:text=A%20computed%20tomography,is%20contraindicated
- <https://www.bing.com/videos/riverview/relatedvideo?q=The+use+of+photodiode+in+X-rays+and+CT+scan&mid=93982B40E5D35A5738AD93982B40E5D35A5738AD&FORM=VIRE>

References

- [B. L. Theraja, A.K Theraja \(2002\).Electrical Technology Electronic Devices Vol. IV; New Delhi: S. Chand & company Ltd.](#)
- [D.C Kulshreshtha, Professor Electronic devices and circuits, 2008 New age international \(P\) Limited.](#)
- [Evans C. Sraha \(2016\) Applied Electricity and Electronics for SHTS \(2016\); Books Galore Ventures. Koforidua.](#)

Review Questions

1. What is a diode, and what is its primary function in electronic circuits?
2. Describe the significance of the depletion region in a diode and how it affects its operation.
3. Explain the role of LEDs in displays and signage systems. What makes them more suitable for this purpose compared to other diodes?
4. How are photodiode arrays employed in medical imaging devices, such as X-ray and CT scanners?
5. Discuss the benefits of using these arrays over other light-sensing technologies

UNIT 6

AUTOMOTIVE TECHNOLOGY

Introduction to Vehicle Technology

INTRODUCTION

This unit will take you through the methods of operating the brakes (*also called actuation*) in today's automobile industry. You will explore the constructional and operational differences between mechanical, hydraulic and pneumatic braking systems. The use of brakes in vehicles dates back to the early nineteenth century when only the mechanical system was available. The system has evolved over the years with significant improvements in its design and application. No matter the type of braking system in use, it is the driver who initiates the braking action by interacting with the system through a pedal or a lever and having efficient brakes is a guarantee of safety in the use of vehicles.

At the end of this unit, you will be able to:

Differentiate between mechanical, hydraulic and pneumatic braking systems.

Key Ideas

- Brakes are essential components of any vehicle, ensuring safety and control during operation.
- The automobile braking system is one way in which friction has proved to be very useful.
- Mechanical, hydraulic, and pneumatic brakes are the most used braking systems used in automobiles
- The selection of any one braking system largely depends on its principles of operation, suitability and advantages
- **Mechanical brakes** rely on physical components; hydraulic **brakes** operate on fluid pressure; and **pneumatic brakes**, often used in larger vehicles like trucks and buses, operate on compressed or pressurised air.

METHODS OF OPERATING VEHICLE BRAKING SYSTEMS

The methods of operating the brakes of vehicles in today's world comes in various forms, including mechanical, hydraulic, pneumatic and electromagnetic systems. Every vehicle is equipped with at least one of these methods of operation, but there are hybrid systems that

operate on a combination of two or more of these methods. The most basic and common ones are discussed in this unit.

1. Mechanical Braking System Operation

The mechanical brake operating system uses physical components to transmit the driver's foot pressure exerted on the brake pedal to the brake assemblies at the wheels. The system is made up of strong parts arranged to form a mechanism that is flexible but strong to absorb or resist all forms of forces in order to transmit precise braking force to the brakes without fail.

Construction of Mechanical Brakes

The components of mechanical brakes include linkages, such as rods, levers, fulcrums, cables, cams, return springs and brake shoes. These components are assembled with appropriate leverages to adequately transfer the required braking force on the vehicle's brake drum or rotor.

Operation of Mechanical Brakes

When the driver presses the brake pedal, the pedal motion is transmitted to the linkages, which convert the pedal force into linear motion. This linear motion is then transmitted to the brake cam, rotating it and converting the linear motion into radial motion. The radial motion expands the brake shoes outward, causing them to contact the brake drum. The friction generated between the brake shoes and drum slows the drum's rotation, which in turn slows down the vehicle. When the driver releases the brake pedal, the return spring retracts the brake shoes, disengaging them from the brake drum. The drum's rotation resumes, allowing the wheel to rotate freely.

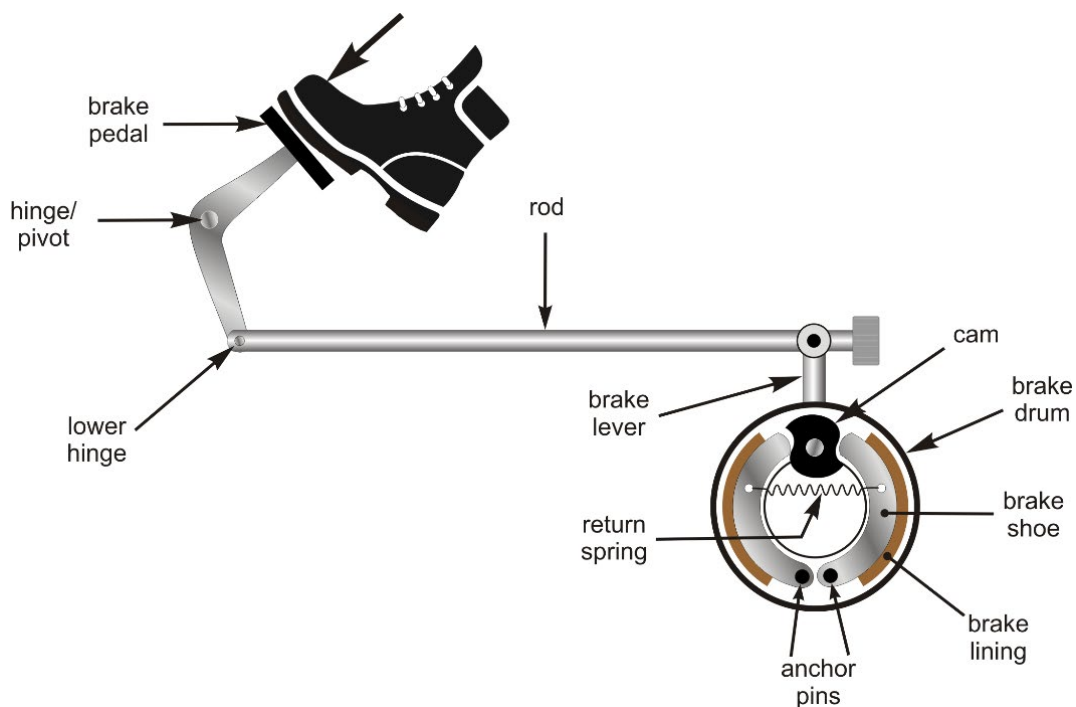

Fig. 5.1.1: A mechanical brake

Mechanical brakes are simple in design, provide reliable braking, and cost less to maintain. However, the braking force at high speeds is very limited and ineffective. While they are no longer the primary braking system in modern vehicles, mechanical brakes remain an essential component of vehicle safety and control. For this reason, they are primarily used as parking brakes (commonly called hand brakes) in modern vehicles.

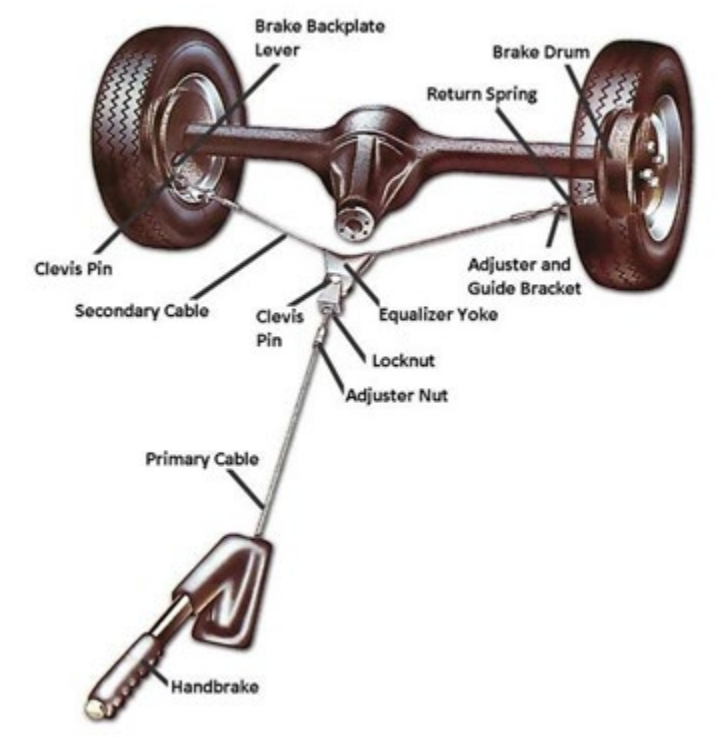

Fig. 5.1.2: A mechanical parking brake

Watch video: ‘Handbrake Car System. How it works?’ at the link below:

<https://www.youtube.com/watch?v=KmE80uW-Auo>

Activity 5.1.1

Prepare a poster of a mechanical braking system to be used as a wall hanging at the auto workshop.

Materials needed

Cardboard

Markers

Straight edge

Activity steps

Watch video: ‘How do Mechanical brakes work?’ at the link below:

<https://www.youtube.com/watch?v=6QjMCseU2hE>

after watching the video, do the following:

1. Draw a margin around the edges of the cardboard.
2. Divide the cardboard into three sections as shown below:

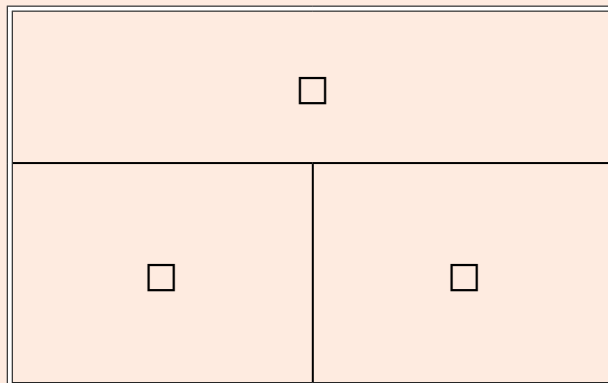

Fig. 5.1.3: Sample of activity cardboard

3. In Section 1, sketch a mechanical braking system and label the parts. Write the advantages and disadvantages of the mechanical braking system in sections 2 and 3 respectively.
4. Select an appropriate title and write it at the top of your drawing.
5. Write your name in the margin at the bottom right corner of your cardboard.

NOTE: You may do this activity as a group.

2. Hydraulic Braking System Operation

Hydraulic braking systems use fluid to transfer braking force from the brake pedal to the brakes at the wheels. Liquids have a non-compressible property, which makes it convenient to transmit the force applied on the brake pedal by the driver's foot to the brakes. The hydraulic connection forms a closed-circuit system to function properly. A good hydraulic braking system must be free from the presence of air.

Construction of hydraulic brakes

Hydraulic brakes consist of a master cylinder, which is the heart of this type of braking system. The master cylinder contains hydraulic fluid (brake fluid) which is stored in the fluid reservoir (tank). The brake pedal connects and transmits the driver's foot pressure to the piston through the pushrod. The piston compresses the brake fluid when the pedal is depressed. The brake mechanisms (wheel cylinders or callipers) at the wheels are connected to the master cylinder through the hydraulic brake lines or pipes. The wheel cylinders or callipers contain pistons which press against the brake shoes (in drum brakes) or rotor (in disc brakes) to slow down and stop the rotating wheel.

Operation of hydraulic brakes

The hydraulic braking system uses [brake fluid](#) to create pressure in a master cylinder when the brake pedal is depressed. The pressurised brake fluid multiplies and transmits the pedal force to the brake callipers or wheel cylinders via fluid lines. The pressure acts on brake

shoes or pads to push against a brake drum or rotor, thereby creating friction between the two parts. The friction slows down and stops the rotating wheel of the vehicle. When the brake pedal is released, the brake fluid returns into the master cylinder, and the pressure on the brake shoes or pads is subsequently released, causing the shoes or pads to retract from the drum or rotor to their initial position.

Hydraulic brakes provide several advantages, including increased braking force, improved cooling of the brakes, and self-adjusting capabilities. They are widely used in modern vehicles due to their reliability, efficiency, and effectiveness.

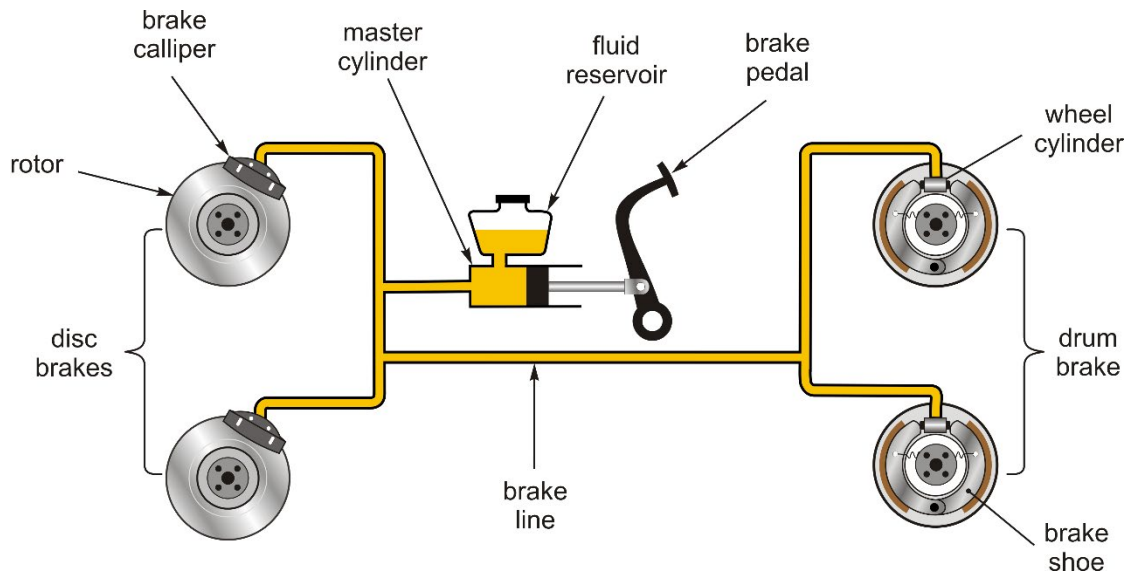

Fig 5.1.4: A hydraulic braking system

Watch video: ‘How do hydraulic brakes in cars and light vehicles work 3D animation’ at the link below:

<https://www.youtube.com/watch?v=82qBBJ8iwcc>

Activity 5.1.2

Demonstrating the principle of hydraulic braking system.

Materials needed

1. 2 hypodermic syringes of unequal sizes
2. Transparent flexible tubing
3. Sellotape
4. Water

Activity steps:

1. Select two syringes, a larger one and a smaller one.
2. Fill the syringes with water, making sure there are no air bubbles trapped in the content.

3. Fill the tubing with water and attach the two ends to the nozzles of both syringes. Make sure the tubing is tightly fitted so that no water leaks. You can use a sellotape to secure the connection.
4. **Fill the tubing and syringes with more water as shown in Fig. 5 below.**

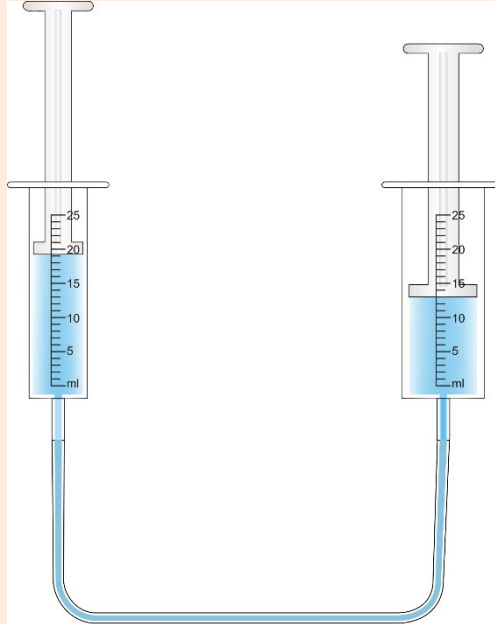

Fig. 5.1.5: Principle of hydraulic system

5. Push the plunger of the larger syringe. Observe what happens.
6. Repeat by pushing the plunger of the smaller syringe. Observe what happens.
7. Based on the experiment conducted, describe, in an essay form, the principle of operation of hydraulic system and how beneficial it can be in the design of a car's braking system.

3. Pneumatic braking system operation

Pneumatic brakes, also known as air brakes, are a type of braking system that uses compressed air to transmit pressure to the brake shoes to reduce the speed or stop the rotating wheel of the vehicle.

Pneumatic brakes are commonly used in heavy vehicles, such as trucks, buses, trailers and tankers. Due to their weight and the large goods they carry, these vehicles require very efficient braking systems to remain safe on the road. For these reasons, they are fitted with air-powered brakes. Air-powered brakes are safer than hydraulic brakes in large vehicles considering the fact that hydraulic fluids can leak and render the brakes less effective.

Another advantage of air brakes over other systems is the availability of the braking medium it uses. The air used in pneumatic systems is very cheap and abundant in the atmosphere, which enables heavy vehicles to rely on air-powered brakes to achieve efficient braking on the roads.

Construction of Air Brakes

The pneumatic braking system consists of a two-stage air compressor, driven either directly by the engine or indirectly through a belt and pulley mechanism. The compressor draws in atmospheric air, compresses it, and stores it in a reservoir (air tank). The compression process is regulated by the governor, which allows air into the reservoir until maximum pressure of about 1000 kPa (kilopascal) or 145 psi (pounds per square inch) is reached. Beyond this cylinder pressure, the unloader valve opens a vent to release excess air into the atmosphere in order to keep the system in a safe working condition.

The compressed air is then distributed to brake chambers through air lines that connect to the brake pedal (also called treadle valve or foot valve). The brake chambers are installed one for each wheel. Each brake chamber contains a diaphragm that responds to the amount of air pressure from the air lines. A pushrod connects the diaphragm to a slack adjuster which converts the linear motion of the diaphragm and pushrod into radial motion that controls the outward and inward movement of the brake shoes. A cam (called S-cam) at the end of the camshaft is responsible for applying the braking force on the brake shoes.

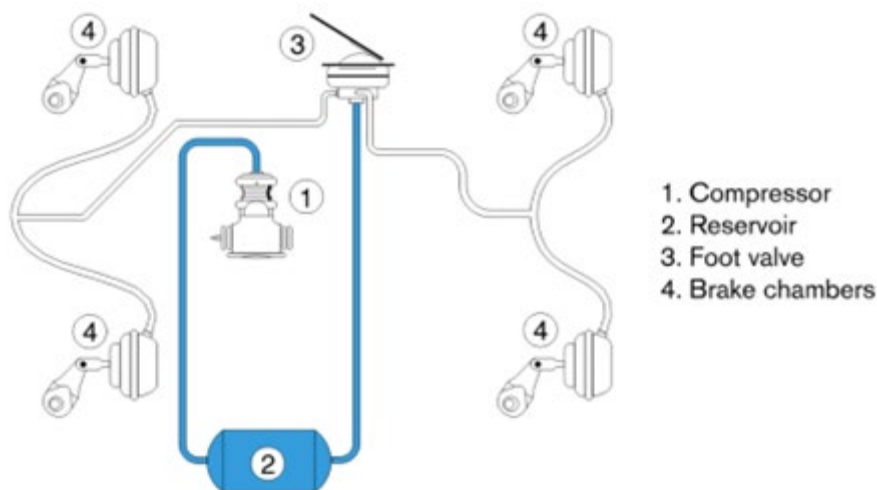

Fig. 5.1.6: Pneumatic braking

Operation of Pneumatic Brakes

The operation of pneumatic brakes begins with the air compressor, which supplies compressed air to the system. This compressed air is stored in the air tank, waiting for the driver's action. When the driver presses the foot valve, the air valve opens, allowing compressed air to flow to the brake chambers. The brake chambers receive this compressed air and convert it into mechanical force, applying pressure to the brake shoes through the pushrod and slack adjuster.

As the brake shoes receive pressure, they move outward, contacting the brake drum and applying friction to slow down or stop the wheel's rotation. As soon as the driver releases the brake pedal, the air valve closes, and the quick-release valve rapidly releases the air pressure from the brake chambers. This rapid release allows the brake shoes to retract, disengaging from the brake drum and freeing the wheel to rotate. The air pressure is then re-built in the system, ready for the next braking application.

Throughout this process, the air brake system relies on precise air pressure control and valve operation to ensure reliable and efficient braking performance. The system's automatic application feature provides additional safety by ensuring that the brakes engage automatically if air pressure drops below a certain threshold. For an efficient operation of the pneumatic braking system, the air tanks must be filled to their recommended working capacity of between 90 and 120 psi.

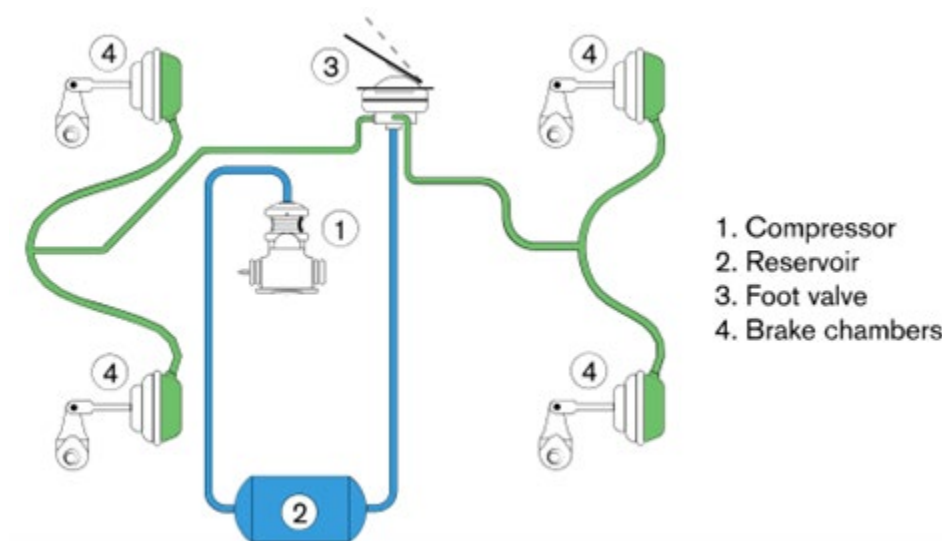

Fig. 5.1.7: Pneumatic braking system (Brakes applied)

Watch video: 'How Air Brakes Work' at the link below:

<https://www.youtube.com/watch?v=twuO2tsuNKO>

Watch video: 'S-cam Air Brakes' at the link below:

<https://www.youtube.com/watch?v=3mrUMTP4thI>

Activity 5.1.3

Using compressed air

Materials needed

Bicycle pump

Football/bicycle tyre

Activity steps

1. The teacher will organise a visit a vulcanising shop in the community to observe how tyre inflation is done.
2. Study the working of an air compressor and a reservoir.
3. Use the bicycle pump to inflate a ball or a bicycle tyre.

NOTE: Do not overinflate above the recommended pressure.

4. Check the weight of the ball or tyre before and after inflation.

5. Based on your observation and experience at the vulcanising shop, discuss the safety precautions you must follow when working with compressed air at the workshop.
6. Write down the key points of the discussion.

Extended Reading

1. [Everything you need to know about hydraulic brakes](https://www.autotrainingcentre.com/blog/infographic-everything-you-need-to-know-about-hydraulic-brakes/)
<https://www.autotrainingcentre.com/blog/infographic-everything-you-need-to-know-about-hydraulic-brakes/>
2. [How the braking system works](https://www.howacarworks.com/basics/how-the-braking-system-works)
<https://www.howacarworks.com/basics/how-the-braking-system-works>
3. [How Do Air Brakes Work? Air Brakes Explained Simply](https://www.uti.edu/blog/diesel/air-brakes)
<https://www.uti.edu/blog/diesel/air-brakes>

References

- [Day, A. \(2014\). Braking of road vehicles. Butterworth-Heinemann: Kidlington, Oxford.](#)
- [Halderman, J. D. \(2012\). automotive technology principles, diagnosis, and service \(4th ed.\) Pearson Education, Inc.: Upper Saddle River: New Jersey, USA.](#)
- [Heisler, H. \(2002\). Advanced vehicle technology \(2nd ed.\) Butterworth-Heinemann: Jordan Hill, Oxford.](#)
- [Hiller Automotive](https://www.hillerautomotive.com/post/what-is-the-principle-of-car-brakes) <https://www.hillerautomotive.com/post/what-is-the-principle-of-car-brakes>
- <https://www.howacarworks.com/basics/how-the-braking-system-works>
- [Lawes, John \(2014\). Car brakes: A guide to upgrading, repair and maintenance, The Crowood Press: Marlborough, Wiltshire.](#)
- [Muir, A. \(n.d\). How the braking system works. How a Car Works.](#)

Review Questions

1. With the aid of diagrams, differentiate between the constructional features of the mechanical, hydraulic and pneumatic braking systems.
2. With the aid of diagrams, describe how the operation of mechanical, hydraulic and pneumatic brakes differ from one another?
3. Complete table 1 below to explain the differences in the component parts of mechanical, hydraulic and pneumatic braking systems.

Table 1: differences in the parts of mechanical, hydraulic and pneumatic braking systems.

Braking system	Key Components	Force Transmission	Medium Used
Mechanical Brakes	e.g. cables,		
Hydraulic brakes	e.g. master cylinder		
Pneumatic brakes	e.g. air compressor		

4. Give any four reasons why the mechanical braking system is no longer being employed as mode of operation for the primary brakes of vehicles today.
5. Explore ten applications each of hydraulic and pneumatic principles in modern times.

Acknowledgments



Ghana Education
Service (GES)



List of Contributors

Name	Institution
Philip Kwesi Incoom	Metro Education Office, Cape Coast
Micheal Kobla Tsorgali	AAMUSTED, Kumasi
Tetteh Bruce	Koforidua SHTS
Frank Fabian Aidoo	Ga North M.E.O, Ofankor
Evans Charles Sraha	Koforidua SHTS