

SECTION

7

BASIC UAV DESIGN

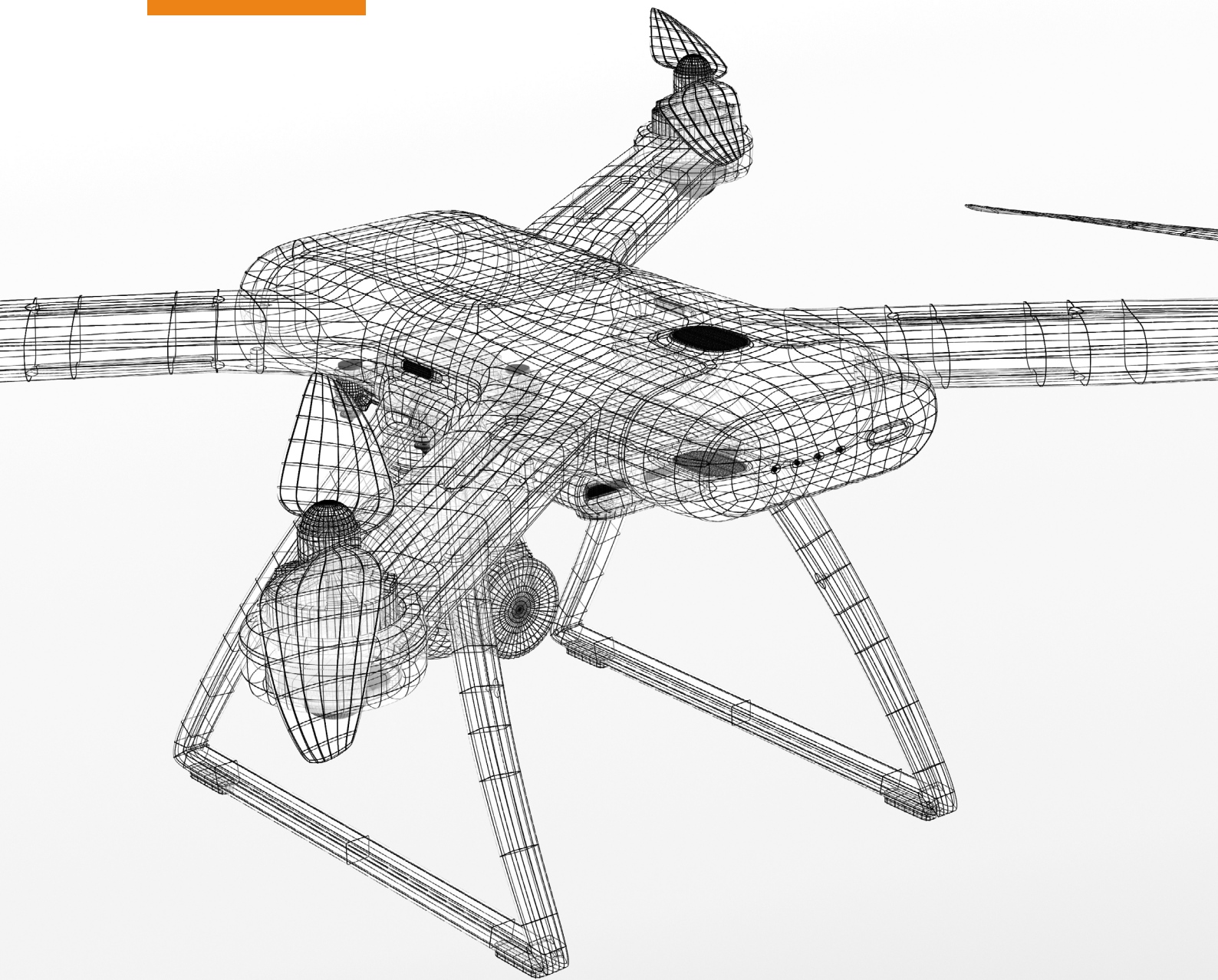

Unmanned Aerial Vehicles (UAVs)

UAV Applications

INTRODUCTION

Here is the opportunity to combine all the concepts you have learned so far to build an aircraft system! In this section, we expect you to demonstrate an understanding of basic aerospace concepts that have been taught and use such knowledge to create a model UAV. As far as possible, collaborate with your friends and teacher to fully understand the basic concepts of aerospace design, through which you can excel as an engineering student. Your teacher will lead you safely through the process of planning, designing, and building a simple UAV system. We wish you the best! Now let us begin with some basic design knowledge.

At the end of this section, you will be able to:

- Explain the principles of operation of UAVs

Key Ideas

- A **Process** is a series of actions or steps taken to achieve a particular end.
- **Engineering design** is the application of knowledge in manufacturing techniques, product development, and prototyping to develop innovations and products or to modify existing ones.
- An **Evaluation Matrix** is a table used to weigh different concepts or ideas based on a given set of criteria to select the best option.
- **Fabrication** is the process of inventing or manufacturing something.

ENGINEERING DESIGN PROCESS AND THE IMPORTANCE OF DESIGN

What is Engineering Design?

Engineering design is a step-by-step way of solving problems using engineering skills, knowledge (like mathematics, science, technology, and environmental studies), and creativity to create and improve products. Before a product is available to the public,

engineers carefully plan how to make it strong and reliable. They run several tests and make changes to the product so it can work better while using fewer resources.

Design Constraints

Many factors can affect the outcome of a design. These are called constraints. Some of these factors include cost, how easy it is to make, time, appearance, availability of materials, the skills needed, strength, and safety. Engineers must always think about these challenges and choose the best solution.

In this session, we will focus on UAV systems, although these constraints cut across every engineering process.

The Design Process

The design process is a set of steps that engineers follow to create and test new products. These steps help them find solutions to problems. The process includes the following stages:

- a. Define the problem and identify constraints:** This is the first step in the design process. It involves stating the problem to understand the challenge that needs to be solved. Engineers must also identify the constraints that may affect the solution. For example, if a farmer has a large piece of land that is being taken over by others, the problem would be finding a way to regularly check the land. The engineer designing a drone (UAV) for this purpose must consider limitations, like whether the land has a runway or where the drone will be stored, which could affect its size. Questions like whether the drone will launch and land in the same spot or be moved around are also important because they will impact its design, such as whether it needs to be modular (easily assembled and disassembled).
- b. Research the problem:** Often, the problem you are trying to solve has been attempted by others, or someone may have solved a similar issue. It is helpful to learn from their designs, improve upon them, and avoid their mistakes. The internet and experts can be great resources for this research.
- c. Brainstorming and generating concepts:** At this stage, engineers think about the information they have gathered and come up with ideas for how the solution will work and look. This is usually supported by technical drawings. It is best to come up with many ideas during this stage.
- d. Concept evaluation and prototyping:** Here, the advantages and disadvantages of each idea are compared using an evaluation matrix, and the best solution is selected. The evaluation matrix is a table that lists the concepts and criteria like cost, ease of manufacture, durability, and appearance. Each concept is evaluated based on these criteria. For example, below is a matrix comparing two design ideas, A and B, with different weights assigned to each criterion, totaling 1.

i. Ease of manufacture

Table 7.1: Scoring criteria for ease of manufacture

Number of welded joints	Score
Less than 5	5
5 – 9	4
10 – 15	3
16 – 20	2
Greater than 20	1

ii. Cost

Table 7.2: Scoring criteria for cost

Number of parts	Score
Less than 5	5
5 – 10	4
10 – 15	3
16 – 20	2
Greater than 20	1

iii. Mobility

Table 3: Scoring criteria for mobility

Mass	Score
Less than 10 kg	5
11 – 15 kg	4
16 – 20	3
21 – 25	2
Greater than 25	1

Table 4: Comparison of two designs in an evaluation matrix

Criterion	Weight	Parameter	Concept A			Concept B		
			Value	Raw score	Weighted score	Value	Raw score	Weighted score
Ease of manufacture	0.3	Number of welded joints	6	4	1.2	10	3	0.9
Cost	0.4	Number of parts	6	4	1.6	12	3	1.2
Mobility	0.3	Mass	8	5	1.5	16	3	0.9
Total	1.0				4.3			3.0

Based on this evaluation matrix, concept A is chosen for prototyping and development because it has the highest weighted score.

- e. **Testing, design, and optimisation:** This stage involves testing and improving the design. It is a crucial step where the product is tested under real-world conditions to see if it works as expected. After testing, adjustments are made to improve its performance.
- f. **Redesign and Testing:** At this stage, the product is redesigned based on the results of the tests. After making changes, the product is tested again to ensure it performs better.

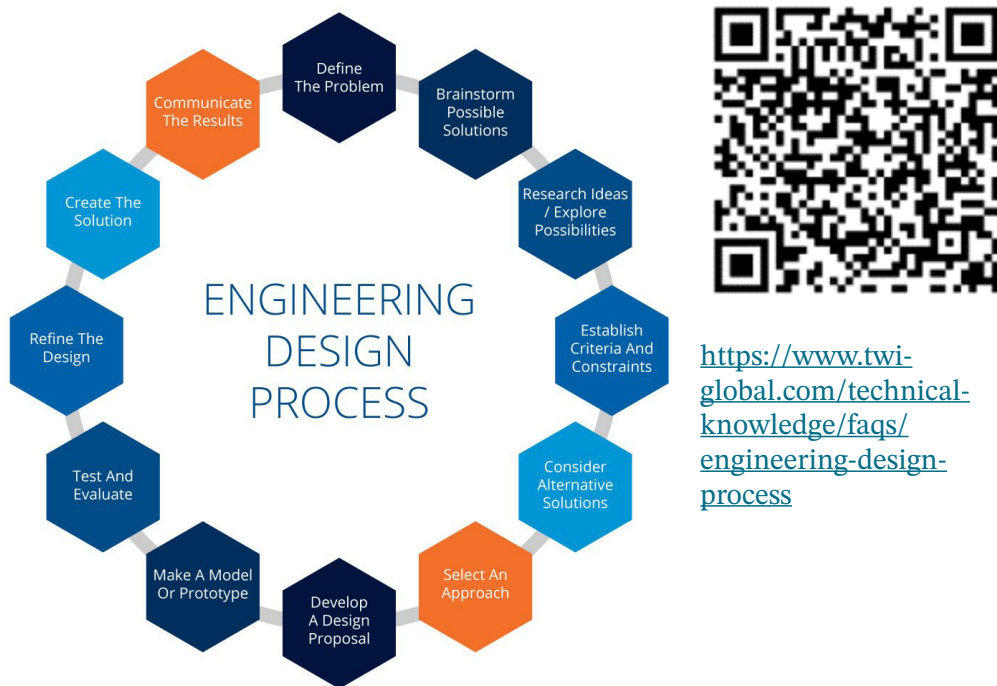

<https://www.twi-global.com/technical-knowledge/faqs/engineering-design-process>

Figure 7.1: Engineering Design Process

Activity 7.1

Use the Evaluation Matrix to pick a solution for a problem

In a small group, follow these steps;

- Identify an engineering problem in your school
- Brainstorm at least three possible solutions to the problem
- With the aid of an Evaluation Matrix, select the best option.
- Discuss the difference between design and haphazard fabrication.
- Present your work to the whole class.

INTRODUCTION TO UAV DESIGN

UAV Build

This concept will require a lot of activities in the laboratory. You will be guided through various practical activities. Please adhere to all laboratory safety rules and ensure that you protect one another whilst working. Participate fully and ask questions for clarification from your teacher where necessary. Before attempting anything that you are not sure of, confirm with a classmate or notify your teacher. Ask your peers for help to ensure you are safe during any activity. Now, enjoy the activity!

Activity 7.2

3D Simulation of Flight

- In the aerospace laboratory, practice flying on a desktop or laptop using any of the following suggested software
 - a. PicaSim
 - b. Microsoft Flight Simulator X
 - c. FlightGear
 - d. MultiFlight
 - e. XPlane10
 - f. XPlane11
 - g. RealFlight
 - h. AeroFly
 - i. FlightDeck etc.
- Practice flying the following;
 - a. Take off
 - b. Rolling
 - c. Pitching
 - d. Yawing
 - e. Coordinated turns
 - f. Recovery from stall
 - g. Engine out emergency landing
 - h. Landing on Instruments only
 - i. Landing in crosswinds
 - j. Power-on stalls
 - k. Flying in heavy precipitation (Instrument Meteorological Conditions, IMC)
 - l. Landing on aircraft carrier deck

- m. Loss of engine power on a helicopter (autorotation)
- n. Landing with asymmetric thrust (loss of engine power on one side of the aircraft)
- o. Flying in mountainous areas

Activity 7.3

UAV Build – Fixed Wing UAV

PROJECT ‘GHANA-FLY’

Follow attentively as your teacher guides you through the following;

1. Airframe Size Estimation

Wing span	150cm
Wing chord	20cm
Wing airfoil	Clarke Y airfoil
Horizontal Tail Span	52.5cm
Horizontal tail chord	15cm
Vertical tail chord	14cm
Vertical tail height	30cm
Tal airfoils	NACA 0012
Fuselage length	130cm
Wing’s trailing edge to horizontal tail	50cm
Fuselage width	15cm
Fuselage height	15cm
Fuselage shape	bulky at mid-section, tapered towards the tail and nose.

2. Electronic components needed

2.4 GHz radio transmitter and receiver	x1
2 kg + thrust brushless DC motor	x2
10-inch propellers	x5 counter-rotating pairs
60A Electronic Speed Controllers	x2
9-13 kg servo motors	x6
Servo push rods	x1 set
LiPo / Li-ion batteries (11.1V – 14.8V)	x2
<i>Optional</i> RC wheels (6cm diameter)	x6
Servo extension wires	x10 (30cm long)
Servo Y wires	x5 (10-20cm long)

3. Airframe materials:

- Styrofoam boards
- Strawboards
- ½ inch plywood board
- ¼ inch plywood board
- Hot melt glue
- 50g superglue
- Epoxy glue – resin and hardener

Procedure*Wings*

- a. Visit www.airfoiltools.com > Airfoil search
- b. Type “Clark Y” in the “Text Search” box and click “Search”
- c. Select the first result
- d. Click “Send to airfoil plotter” on the right side of the page.
- e. Enter 200 in the “Chord (mm)” box, scroll down, and click “Plot”
- f. Click “Open full-size plan in new window” and print the airfoil profile.
- g. Cut out the profile with a sharp knife or scissors.
- h. Put the cut shape onto the ¼ inch plywood board
- i. Mark out and cut ten pieces of the shape (These are the ribs for your wing)
- j. Mark out and cut 150 cm x 1.5 cm of your ½ inch plywood board (This is the main spar of your wing)
- k. Locate the point quarter of the distance from the front of your airfoils
- l. Create a small indent through this point on all airfoils.
- m. Place the airfoils on the 150 cm x 1.5 cm bar of your ½ inch plywood board at 15 cm intervals. (Congratulations! You just finished the wing skeleton!)
- n. Fill the structure with Styrofoam, and sand it to a smooth finish. You may also use your strawboard to cover the structure. (Congratulations again, your wing is almost ready!)

Tail surfaces

- a. Repeat the same procedure for the wings to fabricate the tail surfaces using the ‘NACA 0012’ airfoil instead of the ‘Clark Y’ airfoil. Use 65 mm for the chord length.

Fuselage

- a. Cut four boards of Styrofoam or foamboard 15 cm x 15 cm each.
- b. Glue them together to form a cube, with two ends open. (This is your middle fuselage)
- c. Draw a symmetrical trapezium of height 50cm, one end of width 15cm and the other end of width 8cm.

- d.** Mark out this shape on your foamboard or Styrofoam board. Cut four pieces of this. Glue them together to form a truncated pyramid. (This is the aft fuselage of your plane.)

Empennage / Tail shell

- a.** Draw a rectangle 20 cm x 8 cm. Mark and cut out four pieces of this out of styrofoam. Glue them together to form a solid shell.
- b.** Lay the structure down on its longer side
- c.** Draw a horizontal line through the middle of two opposite sides. Create a hole 15 cm x 1.5 cm symmetrically through the lines on both sides.
- d.** Insert your horizontal tail through these two holes until it aligns perfectly with the centre when viewed from the top.
- e.** Secure the horizontal tail firmly to the shell with glue.
- f.** Draw a line through the middle of the top of your tail shell, along its longer length.
- g.** Create a hole 14 cm x 1.5 cm symmetrically through this line.
- h.** Insert your vertical tail into this hole until it sits on the horizontal tail. (Make sure the vertical tail is standing at 90° to the horizontal tail.)
- i.** Secure the vertical tail firmly to the shell with glue. (Well done! Your tail section is ready!)

Nose Section

- a.** Draw a symmetrical trapezium of height 40cm, one end of width 15cm and the other end of width 6cm.
- b.** Mark out this shape on your foam board. Cut four pieces and glue them together to form a truncated pyramid. (This is the nose fuselage shell of your plane.)

Airframe Assembly

- a.** Glue the aft fuselage shell to the wing-box.
- b.** Glue the nose fuselage shell to the wing-box.
- c.** Carefully align the tail section to the aft fuselage shell and glue them. Make sure the horizontal tail aligns with centre of the wing-box.
- d.** Reinforce the structure as necessary. Pay particular attention to the strength of joints.
- e.** Create a structure for joining the wings to the fuselage (This should be removable, such that you can disassemble for transport or storage.)
- f.** Congratulations! Your airframe is now ready!

Control surfaces

- a.** Draw a line across the mid-section or centre-chord of your wing (75cm from the tips)
- b.** Along the trailing edge of the wings, locate a point 5cm from the tips. Draw a rectangle 25cm long x 5cm thick along the edge towards the centre chord. (These are your ailerons)

- c. Cut out the ailerons and attach them to the wings using hinges. (Make sure they can rotate freely to about 45° up and down)
- d. Repeat this process for the rudder and elevators
(Rudder dimensions: 20 cm x 5 cm, Elevators dimension: 20 cm x 5 cm left, 20 cm x 5 cm right.)

Electronics layout

- a. On the leading edge of the wing, mark two points 30 cm each from the centre chord towards the tips. Install your two brushless motors at these points. (Make sure the motors are parallel to the chord line of the wings when viewed from the side)
- b. Install your Electronic Speed Controllers under the wings just beneath the motors. (This will cool them during the flight)

Note: Depending on whether you are using one or two batteries, watch the video below to see the proper connections you need to make for your motors.

https://www.youtube.com/watch?v=QCSJu_qMUW0



- c. You will need a pair of counter-rotating propellers for the motors. Your motors need to be set up such that one runs opposite to the other.
Warning! Never install propellers when you are setting up your motors!
- d. Watch the following video to see how to install your servo motors. (You need two for ailerons, one for rudder, and two for elevators. Note: Install aileron motors in opposite directions. Install elevator motors in the same direction.)

<https://www.youtube.com/watch?v=CXgsFVymhLA>



Critical! Watch the following video to see the proper setup for your brushless motors, servo motors and transmitter!

<https://www.youtube.com/watch?v=zf1eud0LRKc>



- e. Congratulations! You are all set now. Let's go for a flight!

Pre - Flight Checks

These activities should be undertaken under the supervision of your teacher, to ensure the correct airfield safety checks have taken place. Do not attempt to undertake this activity without appropriate supervision.

- a.** Select a large field devoid of obstructions such as trees, power transmission lines, telephone poles, buildings etc.
- b.** Make sure all internal components such batteries and receiver are firmly secured in the fuselage.
- c.** Make sure wings are firmly attached to the fuselage
- d.** Make sure your aircraft's centre of gravity coincides with the quarter-chord of the wing
- e.** Make sure your aircraft is balanced from side to side.

Flight

- a.** Let a friend hold the aircraft with both hands above the head.
- b.** Move the control surfaces to ensure they turn in the desired directions.
- c.** Slowly push the throttle to about 80%.
- d.** With considerable muscle power, your friend throws the model pointing slightly above the horizontal.
- e.** Take over controls.
- f.** Congratulations, you are airborne now!

Piloting rules

- a.** Be responsible. Never fly your model close to people.
- b.** Always stay below 400feet or 120metres.
- c.** Never fly your model far away from you.
- d.** Do not fly in strong winds or rain.
- e.** Do not distract yourself with anything else.

Post Flight Analysis

Respond to the following questions;

- i.** What were the strengths of your model?
- ii.** What were the weaknesses of your model?
- iii.** In what ways can your model be optimised?
- iv.** Discuss your answers with the class, and take notes of feedback and other useful points raised.

Review Questions

1. You are an engineer appointed by your local government to draft a solution to the following problems in your community.
 - a. Land degradation by surface mining
 - b. Perennial flooding of farmlands

Describe the action plan you would take to tackle these problems.

2. Using 2:1 scale, build a working UAV model based on Project 'GHANA-FLY'.

Answers To Review Questions

1. Responses to both problems should be based on your learning of the engineering design process:
 - a. Define or identify a problem
 - b. Research problem
 - c. Specify requirements
 - d. Brainstorm solutions
 - e. Choose the best solution
 - f. Design and develop
 - g. Build a prototype
 - h. Test and redesign
 - i. Communicate findings
2. Refer to the build procedure and create your design.

REFERENCES AND EXTENDED READING

- <https://study.com/academy/lesson/engineering-design-definition-process.html>
- <https://www.twi-global.com/technical-knowledge/faqs/engineering-design-process>

- <https://www.youtube.com/watch?v=EU3m3KHiCPg>



- <https://www.youtube.com/watch?v=sUL-mHOX3cE>



- https://www.youtube.com/watch?v=LzZ4Oqk_J1Y



ACKNOWLEDGEMENTS



Ghana Education
Service (GES)



List of Contributors

Name	Institution
Bismark Owusu	Afua Kobi Ampem Girls SHS
Obed Frimpong	Fly Zipline
David Kofi Oppong	Kwame Nkrumah University of Science and Technology