

SECTION

5

PRINCIPLES OF
MARKING OUT,
MEASUREMENT
AND GAUGING

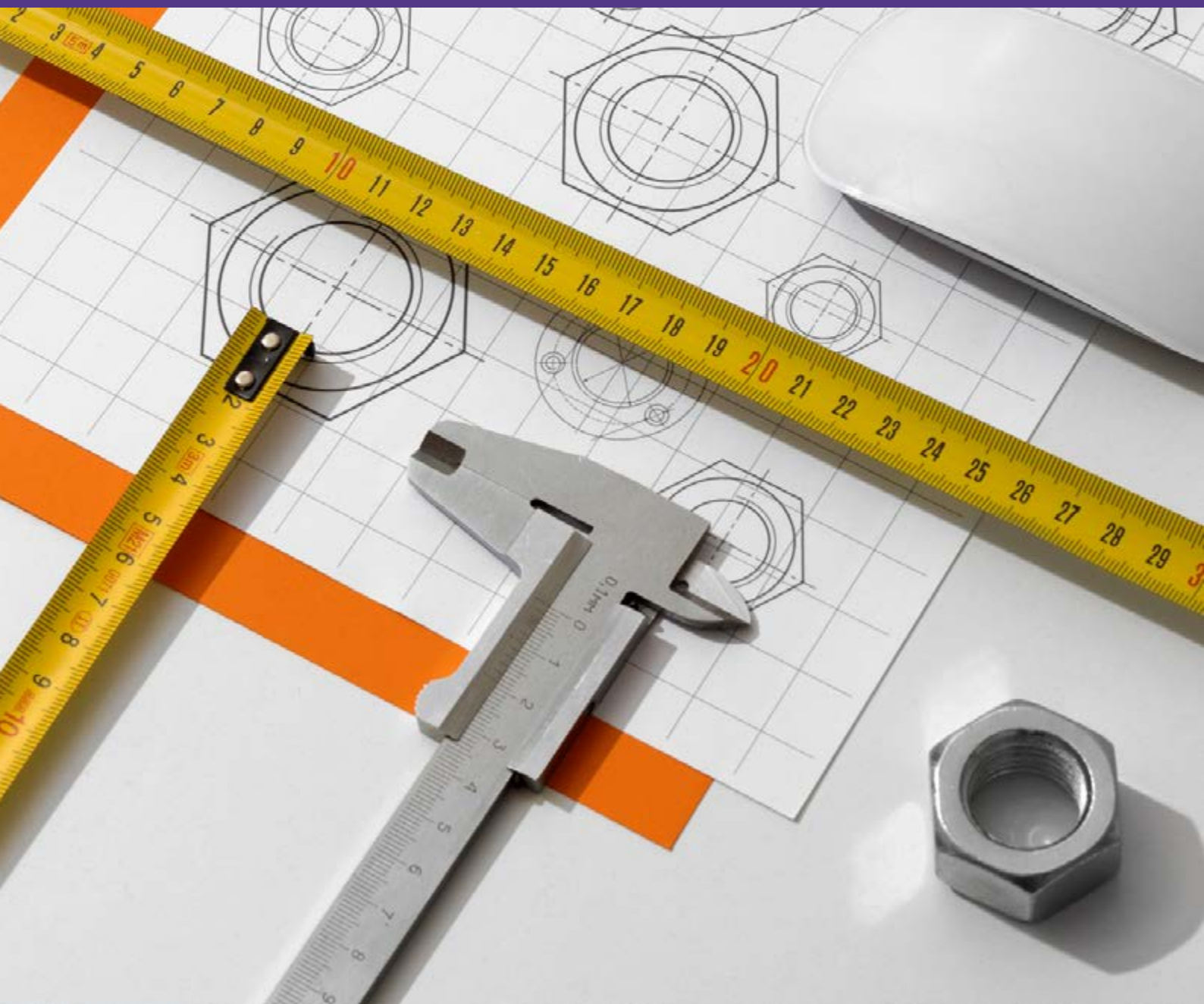

MANUFACTURING TOOLS, EQUIPMENT AND PROCESSES

Manufacturing Tools and Equipment

Introduction

In this section, we shall learn about setting datum lines for a workpiece and selecting coordinate systems when dimensioning objects. The steps and procedures for marking out a workpiece, standard units of measurement, measuring dimensions and gauging will be thoroughly discussed. At the end of this section, you will be equipped with practical skills that will enable you to mark out and differentiate between measuring and gauging. You will be exposed to hands-on activities to help you practice how to mark out to a defined shape using basic manufacturing tools.

At the end of this section, you will be able to:

- Set the datum for a workpiece and select coordinates systems for dimensioning an object.
- Produce a mark out on a workpiece.
- Understand standard units of measurement for workpieces.
- Describe and use gauges to measure the dimensions of a workpiece

Key Ideas

- Marking out is the marking of guidelines on a workpiece to assist a worker to work upon. Marking out requires accurately and precisely transferring design information from an engineering drawing onto a workpiece before any machining, cutting or fabrication.
- Datum selection and coordinate systems are very essential in marking out since they reduce errors in transferring measurement. Datum can be set out as a point, edge or centre line. Gauges such as micrometres, Vernier callipers, odd leg callipers and angle gauges are used to measure the dimensions of workpieces in the workshop.

SETTING A DATUM FOR A WORKPIECE AND SELECTING COORDINATE SYSTEMS WHEN DIMENSIONING OBJECTS

A datum is used to establish a reference position from which all dimensions are taken on a workpiece. It helps to set the reference point used to establish the coordinate system for measurement and tolerance. Datum and coordinate systems are necessary for ensuring accurate design and production of objects. This section discusses how to set the datum for a workpiece and select coordinate systems when dimensioning objects.

Datum

A datum helps to establish a reference position from which all dimensions are taken and all measurements made. A datum may be a point, an edge or a centreline, depending on the shape of the workpiece. For any plane surface, two datum are required to position a point and these are usually at right angles to each other. The selection of a datum depends on the part's function and intended use and can be influenced by the functional requirement of the product, features of the parts, stability, and the manufacturing process. A chosen datum should accurately represent the part's orientation. Point datum, edge datum and centreline datum are commonly used in most manufacturing processes.

Point Datum

A point datum is a fixed and predetermined location on the workpiece that is established when setting up a workpiece for a machining operation. The datum is fixed and serves as the reference point for all measurements and dimensioning during the manufacturing process. In many applications, such as in CNC machining and metrology, a point datum is used as the origin (0,0,0) of a coordinate system from which other measurements and dimensions are defined to ensure precision during the manufacturing process. An example of a point datum is shown in Fig. 5.1. Point datum are often marked using standard symbols on engineering drawings and workpiece surfaces. These markings help technicians to locate and reference the point datum during setup and machining processes.

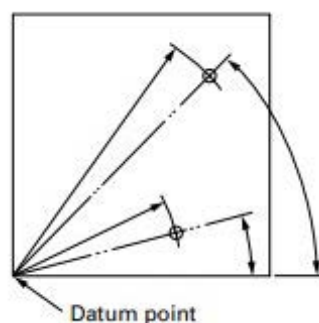

Fig. 5.1: An Example of a point datum

Edge Datum

An edge datum refers to a specific edge or surface on a workpiece that serves as a reference for measurement, alignment or machining operations to ensure accuracy and repeatability in machining operations as shown in Fig. 5.2. An edge datum can also be used as a reference plane in a coordinate system to help define the orientation and position of the workpiece or features relative to the axes of the machine. Standard symbols and markings are made on engineering drawings and the surfaces of workpiece to denote edge datum. These help machinists to locate the edge datum that serves as a guide when setting up the machine tool or workpiece and performing machining operations. The edge datum is also used in assembly and alignment processes to ensure a proper fit and functionality of machine components.

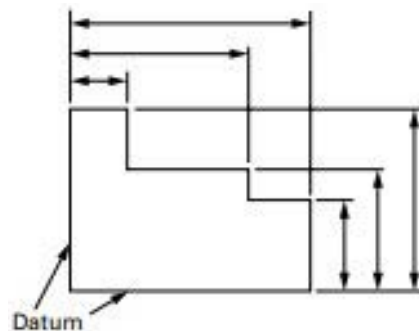

Fig. 5.2: An example of edge datum

Centreline Datum

A centreline datum is an imaginary line or axis that runs through the centre of a cylindrical or symmetrical workpiece as shown in Fig. 5.3. It serves as a reference for measurement, alignment and machining operations, especially when machining symmetrical components such as shafts, cylinders and rotational parts. It defines the central axis around which these components are symmetrically balanced. The centre line datum serves as a reference for aligning and orienting the workpiece or tooling during the setup and machining operations. An accurate establishment of the centreline datum is significant for achieving dimensional accuracy and consistency in manufacturing processes.

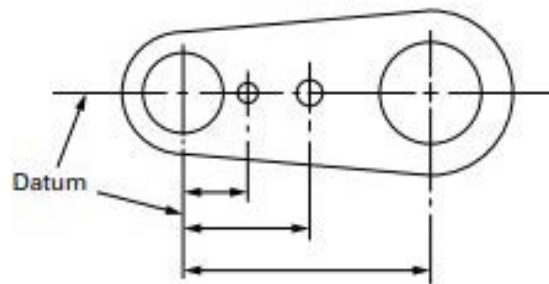

Fig. 5.3: An example of a centre line datum

Coordinate System and Dimensioning

Coordinate systems are used to define the position and orientation of the workpiece. The Cartesian coordinate or rectangular coordinate system, with X, Y, and Z axes, is commonly used when dimensioning a workpiece. In this case, the dimensions are taken relative to the datum at right angles to each other. Other coordinate systems, such as polar cylindrical or spherical coordinates, can be used in special cases.

Origin Point: The origin is the intersection point of the axes (0, 0, 0). This is the starting point for all measurements and dimensioning on the workpiece.

Activity 5.1

1. Click to watch videos to learn more about datum
 - a. <https://youtu.be/qsgIqLLdzAk>
 - b. <https://youtu.be/oviSLCTrkuk>
 - c. <https://www.youtube.com/watch?v=MxvJ9aWbiY8>
 - d. <https://youtu.be/sxXnuSpsn9E>
 - e. <https://youtu.be/OJR3HQYsTVk>
 - f. <https://youtu.be/pa2KNsVLW0o>
2. Now that you have watched these videos, write a brief report on the datum and datum setting as discussed in the videos.
3. Use the headings below to guide you in writing your report.
 - a. Title: A Report on the Datum and Datum Setting
 - b. What are datum?
 - c. Definition.
 - d. How to locate a datum?
 - e. Uses of datum.
 - f. Conclusion

Activity 5.2

Dimension a door hinge using the Cartesian coordinate system.

To perform this activity, you will need a door hinge (example is shown in Fig 5.1), rule, callipers, graph sheet and a pencil. Follow the steps below to dimension the hinge.



Fig. 5.4: An image of a hinge

1. Choose a reference corner or edge of the hinge as the origin (0, 0) of your coordinate system. This point will be used as a base for all measurements.
2. Mark the origin lightly with a pencil.
3. Draw two perpendicular lines at the left-lower corner of your graph sheet and mark the meeting point as the origin (0, 0)
4. Align the paper so that the origin of your coordinate system corresponds to a point on the grid.
5. Measure the length and width of the workpiece from the origin along the X and Y axes.
6. Record these dimensions on your coordinate grid or graph paper.
7. Identify and measure other features such as holes on the hinge.
8. Measure the distance of each hole from the origin in both X and Y directions.
9. Measure the diameter of the hole and note its centre's coordinates.
10. On your coordinate grid or graph paper, plot the measured dimensions.
11. For each feature, mark its position using the X and Y coordinates recorded.
12. Label each point or feature with its dimension and coordinate for clarity.
13. Using the plotted coordinates, create a dimensioned drawing of the workpiece.
14. Include all measurements, features, and their coordinates on the drawing.

Activity 5.3

In a group of three discuss the suitable datum for workpiece and objects of different geometry. Each learner should collect three (3) different items of different materials and geometry.

Items needed are graph sheet, digital callipers, scribe, pencil, ruler and measuring tape. To continue this exercise, first discuss the following to ensure you all have a good understanding of datum:

- Point Datum
- Edge Datum
- Centreline Datum

Perform the following activities with the workpiece.

1. Setup Point Datum

- a. Choose a workpiece with a distinct feature where a point datum can be set.
- b. Choose a reference point on the workpiece (e.g., a corner, a hole-centre, or a predefined mark).
- c. Use a scribe or pencil to clearly mark the datum point on the workpiece.
- d. Measure the distance from this point to other key features on the workpiece and record these dimensions.

2. Setup Edge Datum

- a. Choose a workpiece with a defined edge.
- b. Select one edge of the workpiece as the reference edge.
- c. Clearly mark or highlight this edge using a scribe or pencil.
- d. Measure distances perpendicular and parallel to the datum edge and record these dimensions.

3. Setup Centreline Datum

- a. Select a Workpiece: Choose a workpiece with a symmetrical or cylindrical feature.
- b. For symmetrical workpiece, find and mark the centreline. For cylindrical workpiece, this would be the axis of the cylinder.
- c. Draw or scribe the centreline clearly on the workpiece.
- d. Measure distances from the centreline to other features or edges and record these measurements.

4. Create a Datum Layout

- a. Using coordinate grid paper or a sketch, draw the workpiece and plot the locations of the point datum, edge datum, and centreline datum.
- b. Label each datum and show its relation to other features on the workpiece.

Now that you have worked with the workpiece, have a group discussion on the importance of each type of datum and how they can affect the accuracy of measurements and write a brief report. The report must also contain the challenges faced in setting up datum and how they were addressed.

PRODUCE A MARK OUT ON A WORKPIECE

Marking out is the process of accurately and precisely transferring design information onto the surface of a workpiece before any machining or fabrication takes place. This is made possible using measuring and marking out tools. We will learn about tools that are used when marking out and the marking out process in this lesson.

Marking-out tools

Marking-out tools generally comprise measuring tools and scribes. The measuring tools are used to provide guidelines and accurate measurements for the marking-out process. Some measuring tools include straight edges, dividers, callipers, steel squares, combination squares and many more. These measuring tools are used together with scribes to mark out design geometries on a workpiece.

Straight Edge

It is used when marking out a straight line between two points. It is also used together with squares to draw lines at right angles.



Fig. 5.1: Straight edge tool

Dividers

Dividers are used to mark out shapes onto sheet metals. They work best if a small indent is placed on the sheet metal using a centre punch for one of the legs to rest in.



Fig. 5.2: A pair of dividers

Steel square

The flat steel square and steel try square are used to lay out right angles (90°) and can also be used as a scale. They are important tools for accurate layout work in pattern drafting and come in various sizes.

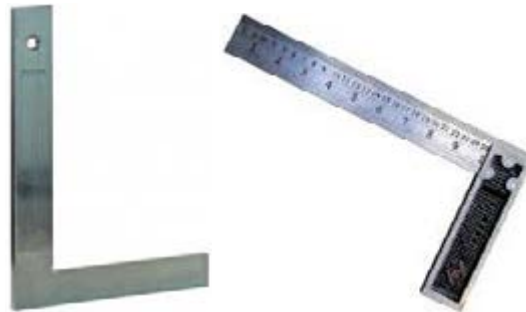

Fig. 5.3: (a) Flat steel square and (b) Steel try square

Callipers

Callipers can be inside or outside callipers. Inside callipers are used to measure the diameter of holes or widths of keyways and slots. Outside callipers are used to measure the outside dimensions of either a flat or round stock. It may also be used to check the parallelism of surfaces.



Fig. 5.4: (a) Inside calliper and (b) Outside calliper)

Scriber

Scribers are used together with steel squares and straight edges to mark lines on a worksheet. They are generally made of steel with one end straight and the other end bent at right angles.



Fig. 5.5: Scriber

Combination set

The combination set is important when making and taking measurements on a workpiece. It has four main parts namely: the steel rule, square head, protractor head and centre head. The steel rule is used in measuring lengths, widths and depths of the workpiece; the square head is used for measuring and marking out perpendicular lines and right angles on a workpiece; the protractor head is used for measuring and marking angles; the centre head is used to locate the centre of cylindrical and circular workpiece.



Fig. 5.6: Combination set

Steps for Marking Out on a Workpiece

1. Understand the engineering drawing or design specifications of the workpiece. This will help you understand the dimensions, tolerances and features that need to be marked on the workpiece.
2. Select the appropriate marking-out tools based on the material of the workpiece and the required precision. Always ensure that marking tools are clean and properly calibrated.
3. Clean the surface of the workpiece to remove any dirt, debris or oil to ensure proper adhesion of the markings and prevent errors.
4. Identify the reference points or features that need to be marked. These might include hole centres, edges, corners, curves and intersections.
5. Accurately transfer measurements from the engineering drawing to the workpiece using the selected marking tools.
6. Double-check all measurements and reference points to avoid mistakes before continuing the marking-out process.
7. Mark out areas of the workpiece that require cutting, machining or drilling. Clearly indicate all dimensions and locations where material needs to be removed.
8. Mark out the necessary points that need alignment or symmetry to ensure accurate assembly or fitting.
9. Inspect all mark-out areas to ensure clarity and accuracy. Make changes where necessary.
10. Consider protecting your markings with marking pens or tapes to ensure durability and avoid the markings being erased.

Tolerance

Tolerance refers to the permissible deviation from a specified dimension in manufacturing processes. There are two main types of tolerance: dimensional tolerance and geometric tolerance. Dimensional tolerance specifies the allowable difference in linear dimensions, such as length, width and thickness, while geometric tolerance specifies the allowable difference in geometric features, such as form, profile, orientation and location.

In a marking-out operation in the workshop, tolerance plays a crucial role in ensuring that components fit together correctly, meeting functional requirements and dimensional constraints. Tolerance impacts the standardisation of parts or assemblies, affecting manufacturing costs significantly. Proper tolerance allocation is essential to control the accumulation of deviations across multiple machining operations called tolerance stack-up. It is essential to measure and verify dimensions against the specified tolerances using precision measuring tools such as callipers, micrometres or height gauges during a marking out process. Checking dimensions and tolerances at various stages of marking out helps identify any discrepancies early on, allowing adjustments to be made before machining or fabrication begins.

Information on tolerance is mostly provided on engineering drawings using standardised symbols, abbreviations and tolerancing methods. Specifications of tolerance must be accurately interpreted and applied during marking out to achieve the desired level of precision and quality in the final product. It is important to consider how individual tolerances stack up during marking out, to ensure that the cumulative variation remains within acceptable limits for the overall assembly. Effective tolerance management ensures product quality, functional capability, manufacturability and cost-effectiveness in the production process.

Activity 5.4

Click to watch the following videos about marking tools.

- a. <https://youtu.be/EpeT4Ku43ow>
- b. <https://youtu.be/NZMTLkVdS5E>

Now that we have watched the videos, let us reflect on the knowledge acquired. Prepare a presentation and present them to your colleagues. After the presentation, encourage your colleagues to ask questions for clarity and on things they did not understand. Explain to your colleagues with your understanding and refresh the content if needed. Use the guide below to prepare your presentation.

A Presentation on Marking-Out Tools Used in Manufacturing

- Introduction
- Define marking-out tools
- Examples of marking-out tools

A table of marking-out tools and their uses in manufacturing

S/N	Tool	Uses
1		
2		
3		

Conclusion

Activity 5.5

The teacher will allocate you to join a group where you will mark out and cut rectangular, cylindrical and conical shapes from metal sheets using the necessary marking-out tools.

The teacher will have set up multiple marking stations in the classroom or workshop, each equipped with different types of workpieces (e.g., wooden blocks, metal plates), marking tools and geometries (rectangular, cylindrical or conical) to be cut. In your group rotate among the marking stations to mark out and cut the necessary geometry in each station using the workpiece at each station and the right marking tool at each station. Follow the “Steps for marking out on a workpiece” above during this task.

UNDERSTAND STANDARD UNITS OF MEASUREMENT FOR WORKPIECES

The Standard units of measurement serves as the foundation for quantifying and comparing physical quantities across various fields and disciplines. It is important that as manufacturers we understand and appreciate the significance of standard units of measurement. These standardised units provide a common language for expressing measurements, enabling precision, consistency and accuracy in scientific, industrial and everyday applications. This lesson delves into the significance and practical applications of standard units of measurement, examining their role in facilitating commerce, engineering, science, manufacturing and everyday life.

Systems of Measurements

The systems of measurement are groups of units of measurement and conventions (rules) relating to each other. Systems of measurement are important in science, commerce, industry and everyday life. There are several systems of measurement used around the world. Some of the most common systems of measurement used in manufacturing

include the metric system/ international system of units (SI), US customary systems and imperial system. Table 19.1 shows some basic units of measurement for imperial and metric systems.

- a. **Metric System/ International System of Units (SI):** This is the most widely used system of measurement globally. It's a decimal-based system, meaning all units relate to each other by factors of 10. This makes it incredibly convenient for calculations and conversions. It is a coherent system based on seven fundamental units: metre (length), kilogramme (mass), second (time), ampere (electric current), kelvin (temperature), mole (amount of substance) and candela (luminous intensity). All other units in the SI system are derived from these fundamental units.
- b. **US Customary System:** This system is primarily used in the United States and to a lesser extent in Liberia and Myanmar. It uses units like inches, feet, miles, pounds, ounces, gallons and Fahrenheit for temperature.
- c. **Imperial System:** This system is historically based on the British Imperial System and is still used in some countries formerly part of the British Empire, such as Ghana (commonly used in most industries but rarely used in educational institutions), Canada and historically in the United Kingdom. It has units similar to the US Customary System but with some variations.

The imperial system has a single set of units for fluid ounces, pints, quarts and gallons whereas the US system has two sets of volume units: one for dry goods (cups, pints, quarts, gallons) and another for liquids (fluid ounces, pints, quarts, gallons). The size of a US fluid ounce is slightly larger than an imperial fluid ounce.

Table 5.1: Basic units of measurement for imperial and metric systems

Unit of Measurement	System of Measurement	
	Metric System (SI Units)	Imperial System
Length	Millimetre (mm)	Inch (in)
	Centimetre (cm)	Foot (ft)
	Metre (m)	Yard (yd)
	Kilometre (km)	Mile (mi)
Mass	Milligramme (mg)	Ounce (oz)
	Gramme (g)	Pound (lb)
	Kilogramme (kg)	Stone (st)
	Tonne (t)	Ton (short ton)

Unit of Measurement	System of Measurement	
	Metric System (SI Units)	Imperial System
Volume	Millilitre (ml)	Fluid ounce (fl oz)
	Litre (l)	Pint (pt)
	Cubic centimetre (cc or cm ³)	Quart (qt)
	Cubic metre (m ³)	Gallon (gal)

Line and End Measurements

Sometimes, distances must be measured between two lines, two surfaces, between a line and a surface or between two points. When the distance between two engraved lines is used to measure the length, it is called line standard or line measurement. An example of standard line measurement is the use of a ruler or a tape measure to determine the length of an object in inches, centimetres or millimetres. The rule with divisions marked with lines is widely used. When the distance between two flat parallel surfaces is considered a measure of length, it is known as end standard or end measurement. The end standards are extensively used for precision measurement in workshops. The most common examples are measurements using slip gauges, end bars, ends of micrometre anvils, Vernier callipers, etc. For an accurate measurement, it is necessary to select a measuring device that suits a particular measuring situation. For example, for a direct measurement of the distances between two edges, a rule is not suitable because it is a line-measuring device.

Table 5.2: Compares Line Measurements and End Measurements.

Characteristics	Line standard	End standard
Principle of measurement	Distance between two engraved lines is used as a measure of length	Distance between two flat and parallel surfaces is used as a measure of length
Accuracy of measurement	Limited accuracy of ± 0.2 mm; magnifying lens or microscope is required for high accuracy	High accuracy of measurement; close tolerances up to ± 0.0005 mm can be obtained
Ease and time of measurement	Measurements made using a scale are quick and easy	Measurements made depend on the skill of the operator and are time-consuming
Wear Markings on the scale are not subjected to wear.	Wear may occur on leading ends, which results in under-sizing	Measuring surfaces are subjected to wear
Alignment	Alignment with the axis of measurement is not easy, as they do not contain a built-in datum	Alignment with the axis of measurement is easy, as they possess a built-in datum

Characteristics	Line standard	End standard
Manufacture	The manufacturing process is simple	The manufacturing process is complex
Cost	Cost is low	Cost is high
Parallax effect	Subjected to parallax effect	No parallax error; their use depends on the feel of the operator
Wringing	Does not exist	Slip gauges are wrung together to build the required size
Examples	Scale	Slip gauges, end bars, ends of micrometre anvils, and Vernier callipers

Measurement of Length

Length is used to measure the dimensions of a workpiece, including its width, height and depth. It is fundamental for defining the size and shape of a part involving quantifying the distance between two points or the extent of an object along a straight line. The universal standard unit of length is the metre. However, the millimetre is used in most workshops due to the sizes of workpieces handled in the workshop. Steel rule, Vernier callipers, micrometres, tape measures and dial indicators are examples of instruments used to measure the length of a workpiece in the workshop. However, the selection of a specific measuring instrument for a given measurement task is contingent upon the requisite accuracy of the measurement. For example, the rule is not applicable for measuring a linear distance of 20.55 mm, given that its minimum measurable increment is 0.5 mm rather than 0.55 mm. Hence, in this case, the rule can accurately measure 20.5 and not 20.55 mm. Table 5.3 shows the conversion of length measurement between different units.

Table 5.3: Length unit conversion

Millimetre (mm)	1
Centimetres (cm)	0.1
Metres (m)	0.001
Kilometres (km)	0.000001
Inches (In)	0.03937
Feet (ft)	0.003281
Yards (yd)	0.001094
Miles (mi)	6.21e-07

Measurement of Diameter

Measurement of diameter involves calculating the distance across the widest part of a circular or cylindrical object. This concept represents a fundamental component of metrology, which finds application across a broad spectrum of disciplines such as engineering, manufacturing and scientific research.

Diameter measurement is fundamental for assessing the size, shape and alignment of cylindrical components, such as pipes, shafts, bearings and cylinders.

The instruments that are commonly used for measuring diameter include callipers, micrometres, dial indicators and specialised tools such as diameter tapes and bore gauges. These instruments allow for accurate and precise measurement of diameter, ensuring proper fit, alignment and functionality of cylindrical objects. In manufacturing, measurement of diameter is essential for quality control and process optimisation. This ensures that machined parts and components meet design specifications and tolerances.

Measurement of Angle

Measurement of angle involves quantifying the rotation or inclination between two intersecting lines or surfaces. Understanding and measuring angles is essential for design and manufacturing tasks. Angles are typically measured in degrees ($^{\circ}$), radians (rad) or other units, depending on the application.

A full circle is divided into 360 degrees, with each degree representing 1/360th of the circle's circumference. Radians, on the other hand, are based on the ratio of the arc length to the radius of a circle and are commonly used in trigonometry and calculus.

Common instruments used for measuring angles include protractors, bevel protractors, combination squares, sine bars, angle blocks, goniometers, theodolites and digital angle finders. These instruments allow for accurate and precise measurement of angles, enabling tasks such as layout, alignment and geometric calculations. Proper calibration, technique and instrument selection are essential to ensure reliable and accurate angle measurements.

Measurement of Volume

Measurement of volume plays an essential role in various scientific, industrial and everyday applications. Volume refers to the amount of space occupied by a three-dimensional object or substance, and accurate measurement is essential for tasks ranging from scientific research and engineering design to manufacturing and commerce.

- a. **Definition and Units:** Volume is typically measured in cubic units, such as cubic metres (m^3), cubic centimetres (cm^3), cubic inches (in^3) or litres (L). The choice of unit depends on the scale of the object or substance being measured and the desired level of precision.

- b. **Direct Measurement:** The most straightforward method of measuring volume involves direct measurement using physical instruments such as graduated cylinders, beakers or volumetric flasks. These containers are marked with calibrated volume graduations, allowing the volume of liquids or bulk solids to be read directly from the scale.
- c. **Displacement Method:** The displacement method is commonly used to measure the volume of irregularly shaped objects or substances. It involves immersing the object in a known volume of liquid (often water) and measuring the change in volume caused by the displacement of the liquid. The volume of the object is then calculated based on the difference in the initial and final volumes of the liquid.
- d. **Geometric Formulae:** For regular geometric shapes such as cubes, spheres, cylinders and cones, volume can be calculated using specific geometric formulae derived from their dimensions. These formulae express volume as a function of length, width, height or radius, depending on the shape of the object.

Measurement of Mass

The measurement of mass is a fundamental aspect of metrology that plays a crucial role in scientific research, industrial processes, commerce and everyday life. Mass refers to the quantity of matter contained in an object, and accurate measurement is essential for tasks ranging from scientific experiments and manufacturing processes to trade and compliance with regulatory standards.

- a. **Definition and Units:** Mass is typically measured in units such as grammes (g), kilogrammes (kg), ounces (oz), or pounds (lb). The choice of unit depends on the scale of the object being measured and the desired level of precision. The International System of Units (SI) defines kilogramme as the base unit of mass.
- b. **Direct Measurement:** The most common method of measuring mass involves direct measurement using a balance or scale. Balances are calibrated instruments that compare the mass of an object to a standard mass, such as weights or calibration masses. The mass of the object is determined by achieving equilibrium between the unknown mass and the standard mass.
- c. **Electronic Scales:** Modern electronic scales use load cells or strain gauges to measure the force exerted by an object due to gravity. This force is then converted into mass using calibration factors and displayed digitally. Electronic scales offer high precision and accuracy and are widely used in laboratory, industrial and commercial settings.
- d. **Weighing Methods:** Different weighing methods are employed depending on the nature of the object being measured. For example, analytical balances are used for precise measurements of small masses in laboratory settings while platform scales are suitable for larger masses such as industrial materials or produce.
- e. **Calibration and Traceability:** Calibration of weighing instruments is essential for ensuring accuracy and traceability in mass measurements. Calibration involves comparing the performance of a weighing instrument to a known standard and adjusting it if necessary to minimise measurement errors. Calibration procedures

are typically conducted according to established standards and guidelines to maintain consistency and reliability.

- f. **Density and Volume Relationships:** Mass measurements are often related to volume measurements through the concept of density, which is the mass of a substance per unit volume. By measuring both mass and volume, density can be calculated, providing valuable information about the composition and properties of materials.

Errors in Measurements

Errors in measurements refer to discrepancies between the measured value and the true value of a quantity being measured. These errors can arise from a variety of sources and can affect the accuracy, precision and reliability of measurement results. Understanding the different types of errors is essential for identifying and minimising their impact on measurement outcomes. Here's an overview of the types of errors in measurements:

- a. **Systematic Errors:** Systematic errors are consistent and repeatable deviations from the true values that occur consistently in the same direction. These errors can result from flaws in measurement instruments, calibration issues, environmental factors or systematic biases in the measurement process. Systematic errors can lead to inaccuracies in measurement results that persist across multiple measurements and are not reduced by averaging.
- b. **Random Errors:** Random errors are unpredictable fluctuations in measurement values that occur randomly and vary in magnitude and direction. These errors can result from factors such as fluctuations in environmental conditions, inherent variability in measurement instruments, or human factors such as inconsistent technique or observation. Random errors can be reduced by taking multiple measurements and averaging the results to minimise the effect of individual fluctuations.
- c. **Instrumental Errors:** Instrumental errors are caused by deficiencies in the measurement instrument itself, such as inaccuracies in the scale readings, zero errors or miscalibrations. These errors can lead to systematic deviations from the true value and can be minimised through regular calibration and maintenance of measurement instruments.
- d. **Observational Errors:** Observational errors occur due to limitations in human perception, judgment or interpretation during the measurement process. These errors can result from factors such as parallax, misreading of scale markings or subjective bias in recording measurement values. Observational errors can be minimised by ensuring proper training, standardising measurement procedures and using appropriate observational techniques.
- e. **Environmental Errors:** Environmental errors are caused by fluctuations or variations in environmental conditions, such as temperature, humidity, pressure or electromagnetic interference. These factors can affect the performance of measurement instruments and lead to inaccuracies in measurement results. Environmental errors can be minimised by controlling environmental conditions, using temperature-stabilised measurement environments or applying correction factors based on environmental monitoring.

- f. **Human Errors:** Human errors result from mistakes or oversights made by individuals involved in the measurement process, such as incorrect data entry, calculation errors or procedural mistakes. These errors can introduce inaccuracies and inconsistencies in measurement results and can be minimised through proper training, adherence to standard operating procedures and double-checking of measurements.
- g. **Gross Errors:** Gross errors are large and obvious mistakes in measurement values that are often caused by equipment malfunction, procedural errors or human mistakes. These errors can be identified and corrected through careful inspection and validation of measurement data.

Activity 5.6

1. Make a search on the internet or watch the videos or read from the textbook on Standard units of measurement using the links and the book provided.
 - a. https://www.youtube.com/watch?v=yP_2QQQIlvk
 - b. <https://www.youtube.com/watch?v=Y4h3UmDmx34>
 - c. <https://www.youtube.com/watch?v=Z8dqhQubv7s>
2. Prepare a presentation on the standard units of measurement, explaining why these units of measurement are used in the manufacturing industry. Then deliver this presentation to your teacher and classmates.
3. Your teacher will give you some selected objects to measure. Measure the length, diameter, volume and mass of these objects using respective measuring instruments and present their results in class.
4. Join a discussion with your class on the importance of using standard measurements (standardisation) in the manufacturing industry.
5. Prepare a report on the headings below and present your findings to your class or peers
 - a. Line and End Measurements
 - b. Errors in Measurements

MEASURING DIMENSIONS USING GAUGES

This lesson the importance of the use of gauges and instruments for the accurate measurement of dimensions in manufacturing and engineering processes. It is important that as manufacturers we understand and appreciate the significance of gauges. Among the array of tools available for this purpose, gauges stand out as essential instruments for capturing dimensions with unmatched accuracy. This lesson delves into measuring dimensions using gauges for ensuring adherence to specifications, identifying deviations and maintaining uniformity throughout the production cycle

Micrometre screw gauge

A micrometre screw gauge is a precision instrument used to measure dimensions with great accuracy, often to the nearest thousandth of a millimetre or micron (μm). A typical micrometre screw gauge has parts as shown in Fig. 5.7 and explained below:

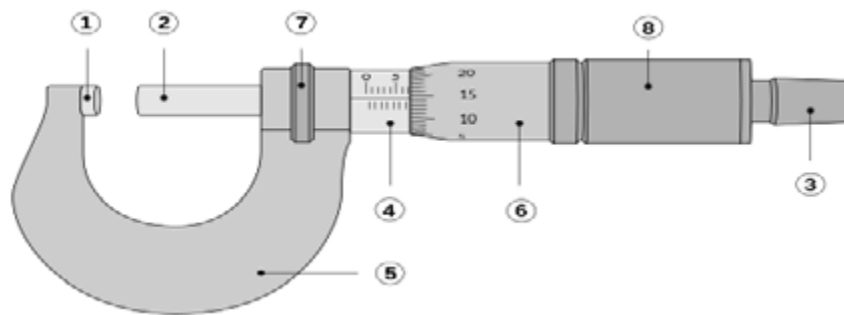

Fig. 5.7: Parts of a micrometre screw gauge

1. **Anvil:** The shiny part that the spindle moves toward, and that the sample rests against.
2. **Spindle:** The shiny cylindrical component that the thimble causes to move toward the anvil.
3. **Ratchet stop:** Device on end of the handle that limits applied pressure by slipping at a calibrated torque.
4. **Sleeve, barrel or stock:** The stationary round component with the linear scale on it. In some instruments, the scale is marked on a tight-fitting but movable cylindrical sleeve fitting over the internal fixed barrel. This allows zeroing to be done by slightly altering the position of the sleeve.
5. **Frame:** The C-shaped body that holds the anvil and barrel in constant relation to each other. It is thick because it needs to minimise flexion, expansion and contraction, which would distort the measurement.
6. **Thimble scale:** Rotating graduated markings.
7. **Lock nut, lock-ring or thimble lock:** The knurled component (or lever) that one can tighten to hold the spindle stationary such as when momentarily holding a measurement.
8. **Thimble:** The component that one's thumb turns.

Steps in using the micrometre

1. Open the micrometre and ensure it's clean and calibrated.
2. Place the workpiece between the anvil (fixed jaw) and the spindle (moveable jaw).
3. Rotate the thimble (or digital display) to move the spindle until it touches the workpiece.
4. Make final adjustment using the Ratchet and tighten the lock nut.
5. Read the measurement from the scale or digital display.
6. To ensure accuracy, make several measurements at different locations and calculate the average.

Vernier Calliper

A Vernier calliper is a versatile measuring tool with both inside and outside jaws and a Vernier scale for high-precision measurements. It can measure external dimensions, internal dimensions and depth. Fig. 5.8 shows a Vernier calliper with labelled parts. The parts labelled are described below:

1. Outside large jaws: used to measure the external diameter of an object (like a hollow cylinder) or width of an object (like a rod) or the diameter of an object (like a sphere).
2. Inside small jaws: used to measure the internal diameter of an object (like a hollow cylinder or pipe).
3. Depth probe/rod: used to measure the depths of an object (like a small beaker) or a hole.
4. Main scale (Metric): marked every millimetre and helps to measure the length correctly up to 1 mm.
5. Main scale (Imperial): marked in inches and fractions.
6. Vernier scale (Metric): gives interpolated measurements to 0.1 mm or better.
7. Vernier scale (Imperial): gives interpolated measurements in fractions of an inch.
8. Retainer: used to block movable part to allow the easy transferring of a measurement.

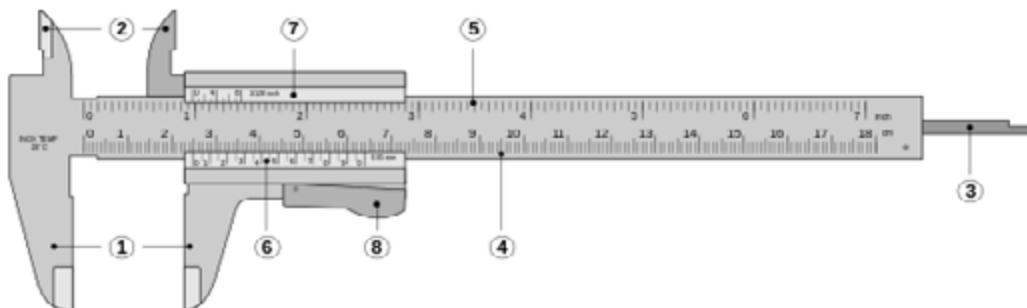

Fig. 5.8: Parts of a Vernier calliper.

Using the Vernier calliper

1. Open the calliper and ensure it's clean and calibrated.
2. For external measurements, place the workpiece between the jaws, aligning it perpendicular to the jaws' axis.
3. Close the jaws gently until they touch the workpiece.
4. Read the measurement from the Vernier scale and the main scale.
5. For internal measurements, use the inner jaws.
6. For depth measurements, use the depth probe.

Reading from the Vernier calliper

To read the measurement readings from the Vernier calliper properly, you need to remember two things. For example, if a Vernier calliper outputs a measurement reading of 2.13 cm, this means that:

- The main scale contributes the main number(s) and one decimal place to the reading (E.g., 2.1 cm, where 2 is the main number and 0.1 is the one decimal place number).
- The Vernier scale contributes the second decimal place to the reading (E.g. 0.03 cm)

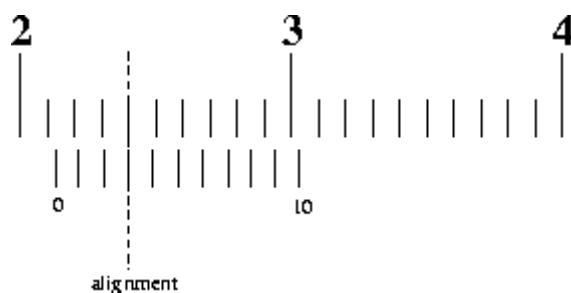

Fig. 5.9: Sample reading from a Vernier calliper

Let's examine Fig. 5.9 for the image of the Vernier calliper reading above. A two-step method can be used to get the measurement reading from this:

1. To obtain the main scale reading: Look at the image above. 2.1 cm is to the immediate left of the zero on the Vernier scale. Hence, the main scale reading is 2.1 cm.
2. To obtain the Vernier scale reading: Look at the image above and look closely for an alignment of the scale lines of the main scale and Vernier scale. In the image above, the aligned line corresponds to 3. Hence, the Vernier scale reading is 0.03 cm.
3. To obtain the final measurement reading, we will add the main scale reading and Vernier scale reading together. This will give $2.1 \text{ cm} + 0.03 \text{ cm} = 2.13 \text{ cm}$.

Angle Gauge

An angle gauge, often referred to as a protractor or bevel protractor, is a tool used to measure angles in a workshop accurately. It is typically a semicircular or full-circle instrument with a calibrated scale, and it can be used for both internal and external angle measurements.

Using the angle gauge

1. Inspect and prepare the angle gauge. Ensure that it is clean.
2. Select the correct type of angle gauge.
3. Position the angle gauge on the workpiece in such a way that the centre point (the pivot point of the gauge) aligns with the vertex of the angle you want to measure.
4. Align one of the gauge's arms or blades with one of the lines forming the angle. Ensure that the blade lies along the line.

Activity 5.7

Aim: How to read a Vernier calliper

Steps to be followed:

1. Familiarise yourself with the Parts:
 - **Main Scale:** The fixed part with graduated markings.
 - **Vernier Scale:** The sliding part that provides a more precise measurement.
 - **Jaws:** Used for measuring the external and internal dimensions.
2. Close the calliper to ensure that the zero mark on the main scale aligns with the zero mark on the vernier scale. If they don't align, you may need to calibrate it.
3. Open the jaws and place the object between them.
4. Close the jaws gently until they make contact with the object.
5. Look at the main scale and note the value just before the zero of the vernier scale. This gives you the whole number measurement.
6. Identify the line on the vernier scale that aligns perfectly with any line on the main scale. This gives you the decimal portion of the measurement.
7. Count the number of divisions on the vernier scale to determine the fraction of the smallest main scale division.
8. Add the main scale reading and the vernier scale reading together for the final measurement.
9. Write down your measurement with the appropriate units (usually millimetres).

Example

- Main scale reads 4 mm.
- The 0.5 mm line on the vernier scale aligns perfectly with a line on the main scale.
- Final measurement = 4 mm + 0.5 mm = 4.5 mm.

Care and maintenance

- Always ensure the calliper is clean before use.
- Hold the calliper firmly but not too tight to avoid damaging it or the object being measured.
- Practice with different objects to become proficient.

With these steps, you should be able to read a vernier calliper confidently.

Activity 5.8

Aim: How to read a micrometre screw gauge

1. Familiarising yourself with the parts:
 - **Frame:** The body that holds everything together.
 - **Anvil:** The stationary part that holds one side of the object.
 - **Spindle:** The movable part that closes in on the object.
 - **Sleeve:** The stationary scale marked in millimetres.
 - **Thimble:** The rotating scale that provides the fractional measurement.
2. Gently close the micrometre screw gauge without applying excessive pressure. Check that the zero mark on the thimble aligns with the zero mark on the sleeve. If they don't align, you may need to calibrate it.
3. Place the object between the anvil and the spindle.
4. Turn the thimble to close the gap until the object is snugly held, but avoid excessive force to prevent damage.
5. Look at the main scale (sleeve) and note the last whole number before the thimble scale starts to cover it. This gives you the whole millimetre measurement.
6. Check the scale on the thimble to find which line aligns with the line on the sleeve. This number represents the fractional part of the millimetre.
7. Each division on the thimble typically represents 0.01 mm (if it's a standard metric micrometre).
8. Add the sleeve reading (whole mm) and the thimble reading (fractional mm) to get the total measurement.
9. Write down the measurement clearly, including the unit (usually in millimetres).

Example

- Sleeve reads 5 mm.
- The 0.25 mm mark on the thimble aligns with a line on the sleeve.
- Final measurement = 5 mm + 0.25 mm = 5.25 mm.

Care and maintenance

- Make sure the micrometre is clean and free of debris.
- Always handle it care to avoid misalignment or damage.
- Practice with various objects to get comfortable with readings.

By following these steps, you'll be able to use a micrometre screw gauge effectively and safely.

Activity 5.9

Visit the school machine shop, for more practical test on how to use the micrometre screw gauge and the Vernier calliper. The workshop attendant/craft master will take you through the correct application of these instruments.

On your own use the gauges to measure and state the diameter/thickness/length of the following

- diameter of different rods
- thickness of different metal plates
- length of bolt

Take a video or picture of yourself taking these measurements during the practical session.

Activity 5.10

Prepare a presentation on the different measuring gauges and their uses in the workshop. Deliver this presentation to your teacher and class when asked.

Review Questions

REVIEW QUESTIONS 5.1

1. List the different ways to set out a datum on a workpiece.
2. What is the primary purpose of establishing a datum on a workpiece when manufacturing a product?
3. Explain how coordinate systems contribute to the dimensioning of a workpiece.

REVIEW QUESTIONS 5.2

1. What factors should be considered when selecting an appropriate marking-out tool for a metal sheet workpiece?
2. Explain the importance of marking out in the manufacturing industry.
3. List the parts of a product that can be marked out on a worksheet.

REVIEW QUESTIONS 5.3

1. Explain the importance of marking out in the manufacturing industry.
2. How can markings made with pens or tapes on a workpiece be protected to ensure that the markings are not erased during the manufacturing process?
3. Identify three (3) potential sources of error when using standard units of measurement, and how can they be minimised or corrected
4. Explain the difference between the metric system and the imperial system of measurement,
5. Explain why standard units of measurement are important in the manufacturing industry
6. Describe the steps involved in accurately using a Vernier calliper to measure the dimensions of a cylindrical object
7. You need to measure the diameter of a metal rod to an accuracy of 0.01 mm. Which gauge would be most appropriate: a steel ruler, a Vernier calliper, or a micrometre? Explain your answer.

Extended Reading

1. Madsen, D., & Madsen, D. (2016). Engineering Drawing and Design ([edition unavailable]). Cengage Learning EMEA. Retrieved from <https://www.perlego.com/book/2707133/engineering-drawing-and-design-pdf> (Original work published 2016)
2. Chapman, W. (1972). Workshop Technology Part 1 (5th ed.). Routledge. <https://doi.org/10.4324/9781315030449>
3. <https://byjus.com/jee/measurement-errors/>
4. Bewoor, A.K., & Kulkarni, V.A. (2018). Metrology and Measurement. CRC Press.
5. Hocken, R.J., & Walter, D.J. (2015). Coordinate Measuring Machines and Systems, Second Edition. CRC Press
6. Sirohi, R.S., & Juneja, K.L. (2011). Introduction to Engineering Metrology. New Age International

ACKNOWLEDGEMENTS



LIST OF CONTRIBUTORS

Name	Institution
Engr. Ali Morrow Fatormah	Mfantsipim School, Cape Coast
Ebenezer Adusei	Kumasi Technical University
Benjamin Atribawuni Asaaga	Kwame Nkrumah University of Science and Technology