

SECTION

7

BASIC ELECTRONICS



VIGOUR BEHIND LIFE

Consumer Electronics

INTRODUCTION

Hello learner, have you ever visited a radio, television or computer repair shop? What are some of the electronic components you remember from your JHS basic electronics lessons?

This section will equip you with an understanding of household electronic devices, their electronic component composition, the uses of these components, and the ability to design a basic amplifier. You will therefore be introduced to household electronic devices such as old/spoilt/abandoned televisions, radios, microwaves, and refrigerators, where available or watch videos about their internal electronic components. You will explore and be introduced to the internal electronic components of the devices like resistors, capacitors, transistors, diodes, and integrated circuits. You will also be guided to design a basic amplifier using electronic components.

At the end of the section, you will be able to

Explain the uses of electronic components in household electronic devices and amplifiers.

KEY IDEAS

- **Electronics:** This is a branch of physics that deals with the emission, behaviour, and effects of electrons. Electronics is concerned with the design of circuits using transistors and microchips, and with the behaviour and movement of electrons in a semiconductor, conductor, vacuum, or gas.
- **Circuit:** A circuit is a closed loop or pathway through which electric current flows.

USES OF ELECTRONIC COMPONENTS IN HOUSEHOLD ELECTRONIC DEVICES

Overview of Electronics

In simple terms, electronics involves manipulating electrical signals to perform specific functions or tasks. It covers many areas, including designing, developing, and manufacturing electronic devices and systems.

Electronics have transformed our lives with the use of smartphones, computers, televisions, kitchen appliances, and medical equipment. Some common components of electronic devices include resistors, capacitors, transistors, and integrated circuits, which are combined to create complex electronic systems. These systems can perform amplification, signal processing, data storage, communication, and control tasks. Electronics is a continuously evolving field with regular advancements and innovations.

Let us now discuss the unique functions of the electronic components in any electronic device.

Electronic Components and Their Uses

Activity 7.1: Electronic components

Fill in the table below with any information that you recall from JHS about the electrical components listed.

After you have filled out as much as you can, watch the video linked below to help you fill out the rest of the table.

https://www.youtube.com/watch?v=XfQs-PQaC_E



Table 7.1: Electronic components, their symbols and functions

Electronic Component	Circuit Symbol	Function
 Resistor		

Electronic Component	Circuit Symbol	Function
 <p>Capacitor</p>		
 <p>Diodes</p>		
 <p>Transistors</p>		
 <p>Inductors</p>		
 <p>Light-emitting diodes (LEDs)</p>		

Activity 7.2: Some common examples of household electronic devices

Having gone through the electronic components, let us remind ourselves that examples of household electronic devices are televisions, refrigerators and washing machines. Discuss with your friend and add to the list.

Consider which of the above-named circuit components may make up the circuitry for the household appliances you have identified. For example, would you expect to find a resistor inside a washing machine? How about an LED? In a pair or group, make a concept map of your thoughts.

If possible, find an old/broken electrical appliance and take it apart to investigate the components inside it.

Now, let us discuss the design of circuits involving transistors and switches.

Designing Circuits Involving Transistors and Switches

A circuit is a closed loop or pathway through which electric current flows. It consists of components like resistors, capacitors, inductors, and power sources connected by conductive wires or traces on a circuit board. Complete the following activity in a group.

Activity 7.3: Experiment on how to build an LED circuit

Aim: To build an LED circuit

Apparatus: Breadboard, LED (Light Emitting Diode), resistor (330 Ohms or appropriate value for the LED), 9V battery and battery clip (or a suitable power supply, connecting wires (jumper wires), multimeter (optional, for testing), switch (optional, to control the LED)

Procedures:

1. Place the breadboard on a flat surface for easy component insertion.
2. Place the LED on the breadboard with the positive anode (longer leg) in one row and the negative cathode (shorter leg) in another row.
3. Connect one end of the resistor to the same row as the anode of the LED.
4. Connect the other end of the resistor to an empty row.
5. Attach the battery clip to the 9V battery.
6. Connect the red wire (positive) from the battery clip to the row with the free end of the resistor.

7. Connect the black wire (negative) from the battery clip to the row with the cathode of the LED.
8. Insert the switch into the breadboard.
9. Connect one terminal of the switch to the row with the free end of the resistor.
10. Connect the other terminal of the switch to the row with the red wire from the battery clip.
11. Double-check all connections.
12. Connect the battery clip to the 9V battery.
13. If using a switch, toggle it to the “on” position.
14. Observe the LED lighting up, indicating a successful circuit.

NB: *if the LED doesn't light up:*

- a. Check all connections for loose wires.
- b. Ensure the LED is correctly oriented (anode to positive, cathode to negative).
- c. Verify the resistor value is appropriate for the LED and power supply.
- d. Use a multimeter to check for continuity and correct voltage levels.

Activity 7.4: Experiment on how to build an electrical circuit

Observe the image in **Fig. 7.1** (note that the reference/link below shows the image as an animation) and carefully complete the experiment that follows.

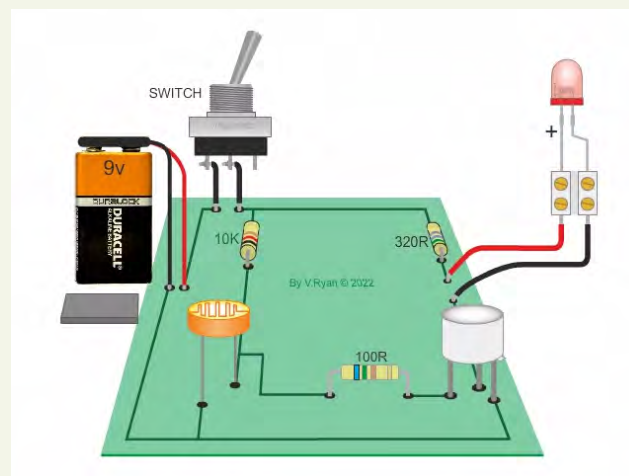

Fig. 7.1: Light dependent resistors.

https://www.technologystudent.com/elec_flash/ldrsensor1.gif

Aim: To build a light-dependent resistor circuit.

Apparatus: Breadboard, LDR (light-dependent resistor), 10k Ohm resistor, LED, 330 Ohm resistor, 9V battery and battery clip, jumper wires.

Procedures:

1. Connect one end of the LDR to the battery's positive terminal.
2. Connect the other end of the LDR to one end of the 10k Ohm resistor.
3. Connect the other end of the 10k Ohm resistor to the battery's negative terminal.
4. Connect the junction of the LDR and the 10k Ohm resistor to the base of an NPN transistor (if using).
5. Connect the transistor emitter to the battery's negative terminal.
6. Connect the collector of the transistor to one end of the 330 Ohm resistor.
7. Connect the other end of the 330 Ohm resistor to the anode (positive terminal) of the LED.
8. Connect the cathode (negative terminal) of the LED to the negative terminal of the battery.
9. The LED should light up when the ambient light levels fall below a certain threshold.
10. Discuss with your group a useful application of this circuit in day-to-day life.

Method of Building an Amplifier

Having looked at the systematic ways of circuit design, let us discuss ways by which you can build an amplifier.

An amplifier is a device that increases the strength (amplitude) of a signal or sound. It takes a weak input signal and produces a stronger output signal, usually with the same waveform but a larger amplitude. Amplifiers are essential in various electronic devices such as audio systems, radios, televisions, and telecommunications equipment to boost signals for better transmission.

Now go through the following process as we build an amplifier. Find further information in **Annex 7.2**.

1. **Determine the Amplifier Type**
2. **Select your Components**

3. Design the Amplifier Circuit
4. Calculate Component Values
5. PCB Layout

Audio frequency (AF) Amplifiers

Activity 7.5 : How to build a simple audio amplifier

- Study the image in Figure 7.2.
- Are you able to identify any of the electronic components?
- Share your response with your friend.

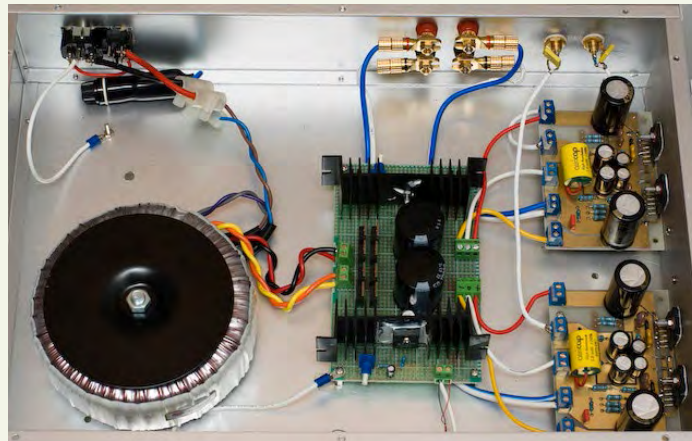

Fig. 7.2: Diagram of Audio Frequency Amplifier

Activity 7.6: Experiment on how to Build a Simple Audio Amplifier

Apparatus: LM386, 10 μF electrolytic capacitor (2 pieces), 0.047 μF ceramic capacitor (1 piece), 10 Ohm resistor (1 piece), 1k Ohm resistor (1 piece), potentiometer (10k Ohm, for volume control), speaker (8 Ohms, small size), audio input jack (3.5mm stereo jack), battery (9V battery with battery clip), breadboard or PCB (Printed Circuit Board), connecting wires, soldering kit (if using PCB)

Procedure:

1. Place the LM386 IC in the middle of the breadboard or PCB for easy wiring.
2. Connect the 9V battery clip to the breadboard or PCB.
3. Connect the positive terminal of the battery clip to pin 6 of the LM386.

4. Connect the negative terminal of the battery clip to the ground rail on the breadboard or PCB.
 5. Connect the audio input jack's ground (sleeve) to the ground rail on the breadboard.
 6. Connect the audio input jack's left or right channel (tip or ring) to one terminal of the 10k Ohm potentiometer.
 7. Connect the wiper (middle terminal) of the potentiometer to pin 3 of the LM386.
 8. Connect a 10 μF electrolytic capacitor between pin 7 and the ground.
 9. Ensure the negative leg of the capacitor goes to the ground.
 10. Connect a 10 μF electrolytic capacitor between pin 1 and pin 8 of the LM386 to set the gain to 200. Ensure the negative leg is on pin 1.
 11. Connect a 0.047 μF capacitor between pin 5 of the LM386 and one terminal of the 10 Ohms resistor.
 12. Connect the other terminal of the 10 Ohm resistor to the speaker's positive terminal.
 13. Connect the negative terminal of the speaker to the ground rail on the breadboard or PCB.
 14. Connect a 220 μF capacitor's positive leg to pin 5 of the LM386 and its negative leg to the junction between the 0.047 μF capacitor and the 10 Ohm resistor.
 15. Double-check all connections to ensure they are correct.
 16. Attach the 9V battery to the battery clip.
 17. Plug an audio source into the input jack and adjust the potentiometer to control the volume.
 18. You should hear the amplified audio through the speaker.
- NB: The concentration should be on the audio amplifier.**





Activity 7.7: Designing your own circuit



In a group of no more than 5 learners, design a circuit to meet a need to fulfil a particular function (for example, a circuit that will light up an LED when the temperature exceeds a certain value or a circuit that will smooth the output of an AC signal).

ANNEXES

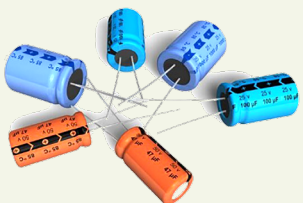
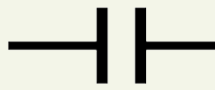
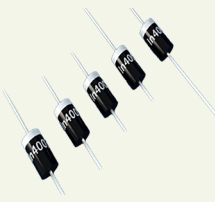
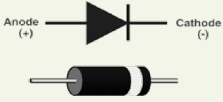
Annex 7.1 – Solutions to some activities

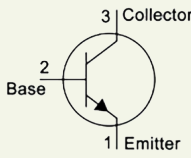
Activity 7.1

Electronic Component	Circuit Symbol	Function
 <p>Resistor</p>		<p>This device restricts the flow of electric current in a circuit, helping to control voltage levels and protect sensitive parts.</p>
 <p>Capacitor</p>		<p>It stores energy in the form of electrical charge and releases the energy when needed. They are commonly used for smoothing voltage fluctuations and filtering out noise in power supplies.</p>
 <p>Diodes</p>		<p>Diodes allow electric current to flow in only one direction and are often used to convert AC (alternating current) to DC (direct current) in power supplies.</p>
 <p>Transistors</p>		<p>These amplify or switch electronic signals. They are crucial in amplifiers, computers, and various digital devices.</p>

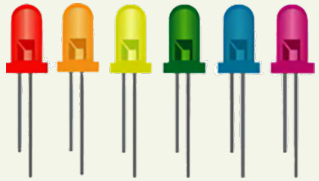
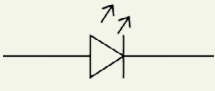
Electronic Component	Circuit Symbol	Function
 <p>Inductors</p>		Inductors store energies in a magnetic field and are commonly used in filters, transformers, and power supplies.
 <p>Light-emitting diodes (LEDs)</p>		They convert electricity into light. They are extensively used in household electronics for indicators.

Activity 7.2

- Microwave ovens
- Air conditioners
- Vacuum cleaners
- Gaming consoles, etc.

Activity 7.4

This circuit would be used in automatic street lighting.

Annex 7.2 – Further information on Electronic Components

How to Design a Circuit

Designing circuits involving transistors and switches typically involves several steps. The following is the general outline of the process:

Define the Objective

- i. It is important to clearly define the purpose of your circuit, for instance an LED circuit.
- ii. Determine what function or task you want the circuit to accomplish.

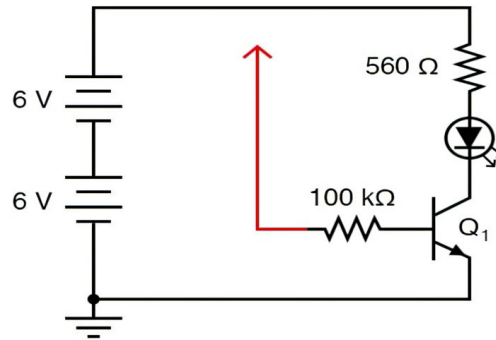

Fig. 7.3: Circuit diagram of transistor as a switch

Circuit Analysis

Use the image in Figure 8 as an example to analyse circuits.

- i. Identify the components and their connections needed to achieve the desired functionality.
- ii. Consider the input and output requirements, power supply, voltage levels, and specific constraints.

Transistor Selection

- i. Select the appropriate transistor type (s) for your design based on your circuit analysis. Common types include bipolar junction transistors (BJTs) and field-effect transistors (FETs).
- ii. Consider factors such as current handling capacity, voltage ratings, speed, and other specifications relevant to your circuit.

Component Sizing

In component sizing

- i. Determine the values of resistors, capacitors, and other components required to bias and drive the transistors properly.
- ii. Calculate or choose appropriate component values based on the desired performance and the transistor's datasheet specifications.

Circuit Simulation

Utilise circuit simulation software such as Linear Technology Spice (LTspice) or Proteus to simulate and validate your circuit's performance. This can help identify potential issues, optimise component values, and achieve the desired functionality.

Printed circuit board (PCB) Layout

If you plan to create a (PCB) for your design, create a layout incorporating the components, their connections, and proper trace routing. Consider factors such as component placement, signal integrity, and thermal considerations.

Prototype and Testing

- i.** Build a physical prototype of your circuit using the designed PCB or a breadboard.
- ii.** Test how the circuit function, perform and check whether it is reliable.
- iii.** Make any necessary adjustments or modifications based on the test results.

Documentation

Document your circuit design, including schematics, component values, and any specific design considerations. This documentation will be useful for future reference, troubleshooting, or sharing your design with others

Process Of Building An Amplifier Circuit

Determine the Amplifier Type

Decide on the type of amplifier you want to build, such as a class A, class AB, class D, or a specific audio amplifier design. Each type has its characteristics and applications.

Select your Components

Choose the necessary components for your amplifier design. This typically includes transistors (bipolar junction transistors or MOSFETs), resistors, capacitors, and possibly transformers or inductors, depending on the amplifier type. Refer to an amplifier circuit diagram or schematic for component values and specifications.

Design the Amplifier Circuit

Create a circuit diagram or schematic based on the selected amplifier type and component choices. This diagram will illustrate how the components are connected and the flow of signals through the amplifier.

Calculate Component Values

Determine the values of resistors, capacitors, and other components based on the desired performance and the amplifier design specifications. This may involve biasing, gain, stability, and frequency response calculations.

PCB Layout

If you plan to create a printed circuit board (PCB) for your amplifier, design the layout incorporating the components and their connections. Pay attention to proper trace routing, ground planes, and thermal considerations to ensure optimal performance and reliability.

EXTENDED READING

- Search internet resources such as Khan Academy, All About Circuits, or Electronics Hub for self-study and exploration.
- Draw different circuit diagrams involving LEDs, capacitors, connecting wires, dry cells, diodes, and resistors.
- <https://technologystudent.com/elec1/ldr1.htm>
- Basic Electronic Components – <https://www.eleccircuit.com/quick-learn-basic-electronic-components/>
- https://www.elenco.com/wp-content/uploads/2017/10/ECK-10_REV-O-2.pdf

REVIEW QUESTION

Review Questions 7.1

1. You are assigned to design and build a basic audio amplifier circuit that can amplify a weak audio signal from a microphone to drive a small speaker.
2. Describe the key electronic components you would use in your amplifier circuit and their roles (e.g., transistors, resistors, capacitors).
3. Explain how you would use these components to achieve the desired amplification.
4. What considerations would you take into account regarding power supply requirements and component ratings?
5. Discuss any additional features you might include in your design to improve sound quality or functionality (e.g., tone control, volume control).

Considerations:

- Specify the expected input and output signal levels.
- Describe how you would test and troubleshoot the amplifier circuit once built.

REFERENCES

1. <https://www.instructables.com/Simple-Audio-Amplifier-Using-Single-Transistor/>
2. Mojtaba A and Teeba Y. (2022) - The electronic Components and their applications; AUIQ, Al-Ayen University. DOI:10.13140/RG.2.2.23840.66566
3. <https://arl.human.cornell.edu/linked%20docs/Make%20-%20Electronics.pdf>
4. Paul H. and Winfield H. (1989); “The Art of Electronics” (2nd Edition, 2015)
5. Albert Malvino and David Bates (2014); “Electronic Principles”
6. Charles K. Alexander and Matthew N.O. Sadiku (2017); “Fundamentals of Electric Circuits”
7. Paul Scherz and Simon Monk (2016); “Practical Electronics for Inventors”

ACKNOWLEDGEMENTS



Ghana Education
Service (GES)



List of Contributors

Name	Institution
Prof. Christian A. Krueger	UCC, Cape Coast
Emmanuel O. Ocquaye	GES, Science Education Unit, Accra
Rev. Thomas K. Arboh	Police Education Directorate, Accra
Samuel Bismark Larbi	Mfantsipim School, Cape Coast