

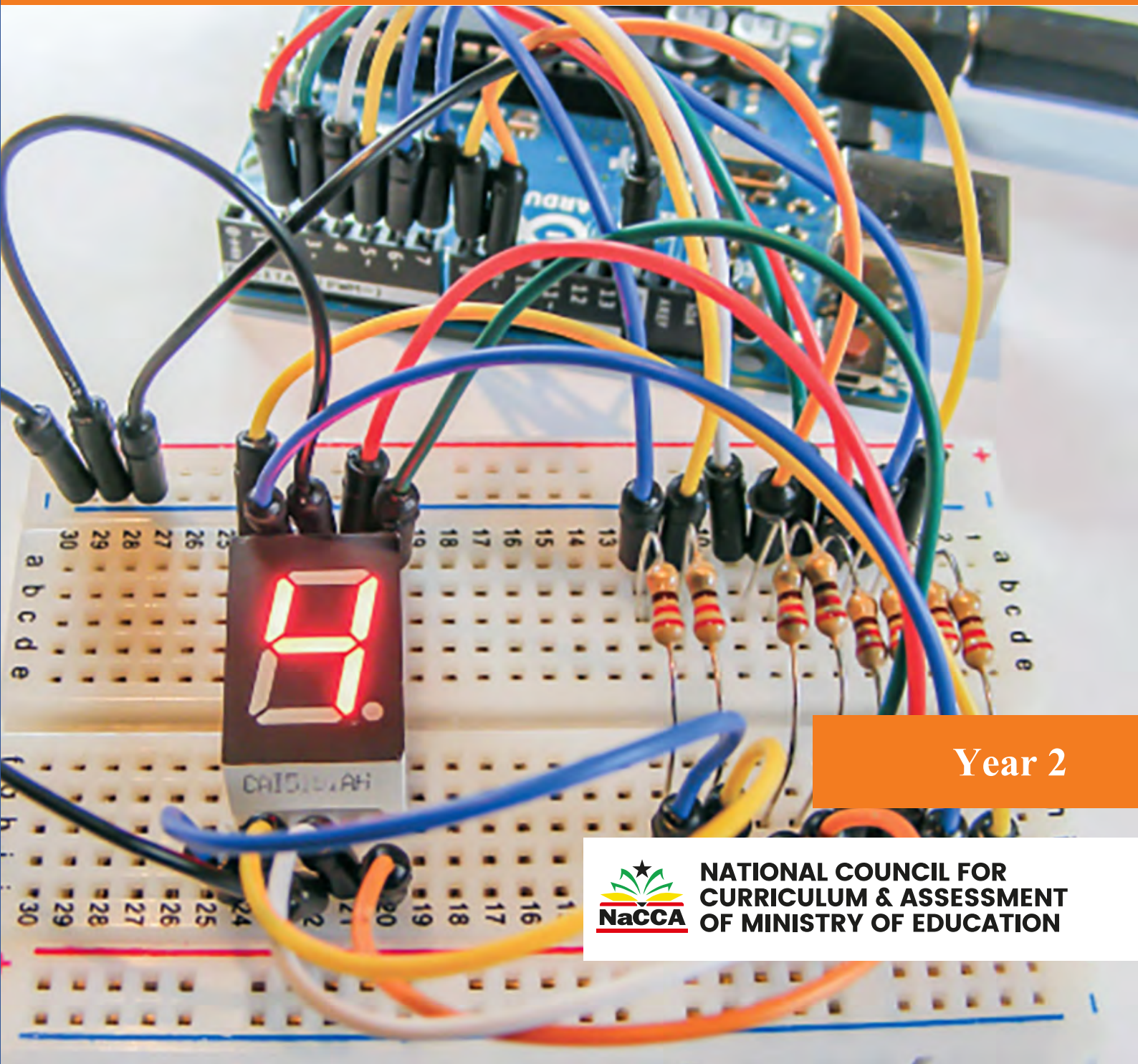

MINISTRY OF EDUCATION

# GENERAL SCIENCE for Senior High Schools

TEACHER MANUAL



Year 2



NATIONAL COUNCIL FOR  
CURRICULUM & ASSESSMENT  
OF MINISTRY OF EDUCATION

# MINISTRY OF EDUCATION



REPUBLIC OF GHANA

## **General Science** for Senior High Schools **Teacher Manual** Year Two



**NATIONAL COUNCIL FOR  
CURRICULUM & ASSESSMENT  
OF MINISTRY OF EDUCATION**

## GENERAL SCIENCE TEACHER MANUAL

Enquiries and comments on this manual should be addressed to:

The Director-General  
National Council for Curriculum and Assessment (NaCCA)  
Ministry of Education  
P.O. Box CT PMB 77  
Cantonments Accra

Telephone: 0302909071, 0302909862

Email: [info@nacca.gov.gh](mailto:info@nacca.gov.gh)

website: [www.nacca.gov.gh](http://www.nacca.gov.gh)



©2025 Ministry of Education

This publication is not for sale. All rights reserved. No part of this publication may be reproduced without prior written permission from the Ministry of Education, Ghana.

# Contents

<b>INTRODUCTION</b>	<b>IX</b>
<b>ACKNOWLEDGEMENTS</b>	<b>X</b>
<b>SECTION 1: NATURE OF DIFFERENT LIQUIDS IN LIFE</b>	<b>1</b>
Strand: Exploring Materials	1
Sub-Strand: Science and Materials in Nature	1
<b>Week 1</b>	<b>3</b>
Focal Area: Acids, Alkalis/Bases and Water	3
<b>Week 2</b>	<b>15</b>
Focal Area: Application of Acid and Bases in Salt Formation	15
<b>Week 3</b>	<b>23</b>
Focal Area: Using the pH Scale to Identify the Concentration of Acids and Bases/Alkalis Solution	23
<b>Week 4</b>	<b>36</b>
Focal Area: pH Measurement	36
Marking Scheme for the Demonstration Assessment Task	48
Marking Scheme for the Discussion Assessment Task	48
Marking Scheme for the Class Exercise Assessment Task	50
Appendix A: Individual Portfolio for Learners' Academic Achievements	51
Appendix B: Group Project on Concept Map	60
<b>SECTION 2: HUMAN EXCRETORY ORGANS</b>	<b>63</b>
Strand: Processes for Living	63
Sub-Strand: Essentials for Survival	63
<b>Week 5</b>	<b>65</b>
Focal Area: Understanding the Structure and Function of Human Excretory Organs	65
<b>Week 6</b>	<b>72</b>
Focal Area: Understanding the Structure and Function of Human Excretory Organs	72
<b>Week 7</b>	<b>81</b>
Focal Area: Processes of Removing Waste from the Human Body via the Kidneys	81

<b>Week 8</b>	<b>88</b>
Focal Area: Processes of Removing Waste from the Human Body	88
<b>Week 9</b>	<b>92</b>
Focal Area: Disorders of the Human Excretory System	92
Rubrics for the Presentation Assessment Task	106
Appendix D: Mid of Semester Examination	110
<b>SECTION 3: GASEOUS EXCHANGE IN HUMANS</b>	<b>120</b>
Strand: Processes for Living	120
Sub-Strand: Essentials for Survival	120
<b>Week 10</b>	<b>122</b>
Focal Area: Movement of Air in Humans and its Importance	122
<b>Week 11</b>	<b>131</b>
Focal Area 1: Structure of the Lungs and Aerobic Respiration	131
<b>Week 12</b>	<b>138</b>
Focal Area: Effect of Smoke and Common Respiratory Disorders and their Impact on Health	138
Rubrics for the Essay Type Assessment Task	156
Rubrics for the Practical Assessment Task	159
Appendix D: End of Semester Examination	164
<b>SECTION 4: CONCEPTS OF ELECTRICITY</b>	<b>168</b>
Strand: Vigour Behind Life	168
Sub-Strand: Powering the Future With Energy Forms	168
<b>Week 13</b>	<b>170</b>
Focal Area: the Concept of Electrical Energy and Power	170
<b>Week 14</b>	<b>191</b>
Focal Area: Energy Audits and Savings Plans	191
<b>Week 15</b>	<b>201</b>
Focal Area: Principle of Transformer and its Function	201
Marking Scheme for the Computational Assessment Task	206
Marking Scheme for the Gamification Assessment Task	207
Appendix E: Individual Project	208
<b>SECTION 5: BUOYANCY FORCE</b>	<b>216</b>
Strand: Vigour Behind Life	216
Sub-Strand: Forces Acting on Substances and Mechanisms	216
<b>Week 16</b>	<b>218</b>
Focal Area: the Relationship Between Upthrust and the Law of Floatation	218

Marking Scheme for the Case Study Assessment Task	224
<b>SECTION 6: ELECTRONICS</b>	<b>225</b>
Strand: Vigour Behind Life	225
Sub-Strand: Consumer Electronics	225
<b>Week 17</b>	<b>227</b>
Focal Area: Principle of Doping Behaviour About Semiconductors	227
<b>Weeks 18 &amp; 19</b>	<b>235</b>
Focal Area: Experimenting With Led and Diode Circuits to Build Phone Chargers	235
Marking Scheme for the Test of Practical Assessment Task	240
Marking Scheme for the Checklist Assessment Task	241
Appendix F: Mid of Semester Examination	242
<b>SECTION 7: PATHOGENIC DISEASES</b>	<b>244</b>
Strand: Relationships With the Environment	244
Sub-Strand: the Human Body and Health	244
<b>Week 20</b>	<b>246</b>
Focal Area: Pathogenic Diseases	246
<b>Week 21</b>	<b>256</b>
Focal Area: Pathogenic Diseases Within the Community	256
Marking Scheme for the Group Simulation Assessment Task	274
<b>SECTION 8: INDIGENOUS BEVERAGES</b>	<b>283</b>
Strand: Relationships With the Environment	283
Sub-Strand: Technology in Local Industries	283
<b>Week 22</b>	<b>285</b>
Focal Area: the Science Involved in the Production of Indigenous Beverages	285
<b>Week 23</b>	<b>291</b>
Focal Area: Production of Indigenous Beverages Such As Asaana	291
<b>Week 24</b>	<b>294</b>
Focal Area: Production of Indigenous Beverages Such As Sobolo	294
Marking Scheme for the Field Trip Assessment Task	297
Marking Scheme for the Homework Assessment Task	298
Appendix G: End of Semester Examination	299
<b>BIBLIOGRAPHY</b>	<b>303</b>

# List of Figures

Fig. 2.1: Reaction between dilute sulphuric acid and Zinc	18
Fig. 2.2: Reaction acetic acid and carbonate	19
Fig. 4.1: Diagram of pH meter.	42
Fig. 5 1: Diagram of excretory organs	65
Fig. 5. 2: A labelled diagram of skin	67
Fig. 5.3: A well labelled diagram of the liver	72
Fig. 5.4: A well labelled diagram of liver	73
Fig. 5.5: A Diagram of segments of the liver	74
Fig. 7. 1: A diagram showing the position of the kidney in human	81
Fig. 7. 2: A well-labelled diagram showing the parts of the human kidney	82
Fig.7. 3: A well-labelled diagram showing the parts of the human nephron	83
Fig. 9.1: Diagram showing a healthy and unhealthy kidney	92
Fig.9. 3: Diagram showing various skin disease	96
Fig.9. 4: Diagram of liver disorders	100
Fig. 10.1: A diagram showing Breathing in air	122
Fig.10.2 : A diagram of the bronchial tree of the lungs	123
Fig. 10.3a: A concept map of air pathways through the lungs	123
Fig. 10.3b: A diagram showing the respiratory pathways	123
Fig. 10. 4: A diagram of the mechanism of Inhalation and Exhalation	125
Fig. 10.5: Diagram showing excretion of waste by the lungs	126
Fig. 10.6: Diagram showing respiration in the lungs	128
Fig. 11.1: A well-labelled diagram of the lung.	131
Fig. 11.2: A diagram of the breathing process.	135
Fig. 12.1: A diagram showing smokers' lung versus healthy lung	139
Fig. 12.3: diagram showing normal and asthmatic lungs.	144
Fig. 12.4: A diagram of a pneumonia lung.	149
Fig. 12.5: A diagram showing a cancerous lung	153
Fig. 13.1a, b, c, d: Diagram showing creating a lemon battery	173
Fig. 13.1: A simple series circuit	178
Fig.13.2: diagram of electric circuit Fig.13.3: diagram of a schematic electric circuit	179

Fig. 13.4: Diagram of resistors in series	179
Fig. 18: Diagram of current in a series circuit.	180
Fig.13.4 : Analogue electric meter	194
Fig. 13.5: Digital electric meter	195
Fig. 15.1: A well-labelled diagram of a Transformers	201
Fig. 16.1: A picture of an aluminium foil-made canoe	221
Fig.18.1: Picture of voltage regulator	235
Fig 18.2: Diagram of breadboard circuit	236

# List of Tables

Table 1.1: lists of a few common organic acids along with their sources.	3
Table 1.2: lists of a few significant mineral acids along with their formulas.	3
Table 1.3: Uses of acids	5
Table 1.4: Uses of Bases / Alkalis	8
Table 1.5: Similarities between acids and bases	12
Table 2.1: Uses of salt	20
Table 4.1: Types of pH meters based on Portability	38
Table 4.2: Types of pH meters based on Usage	38
Table 4. 3: Applications of pH Meters	40
Table 4.4: Types of pH Indicators	42
Table 4.5: pH indicator	43
Table 5.1: shows excretory organs and their excretory products	66
Table 5.2: shows parts of the skin and their function:	67
Table 5.3: Functions of the Human Skin	68
Table 7.1: Parts and function of the kidney	82
Table 7.2: parts of nephron and their function:	83
Table 10.1: Difference between inhalation and exhalation	125
Table 11.1: Parts of the lungs and their function	132
Table 11.2: Features associated with different parts of the lungs	133
Table 11.3: Difference between breathing and respiration.	134
Table 13.1: Components of electrical circuit, their function and their circuit symbol	170
Table 13.2: The table shows common issues of household appliances and their troubleshooting steps	186
Table 20.1: Symptoms of some common virus diseases, the causative organism, mode of transmission and preventive measures against the disease	252
Table 20.2: Symptoms of some common bacterial diseases, the causative organism, mode of transmission and preventive measures against the disease.	253
Table 20.3: Symptoms of some common protozoan (phylum or grouping of phyla which comprises the single-celled microscopic animals, which include amoebas, flagellates, ciliates, sporozoans, and many other forms) diseases, the causative organism, mode of transmission and preventive measures against the disease.	253
Table 20.4: Symptoms of some common Helminthic worm diseases, the causative organism, mode of transmission and preventive measures against the disease	254

# Introduction

The National Council for Curriculum and Assessment (NaCCA) has developed a new Senior High School (SHS) curriculum which aims to ensure that all learners achieve their potential by equipping them with 21st Century skills, competencies, character qualities and shared Ghanaian values. This will prepare learners to live a responsible adult life, further their education and enter the world of work.

This is the first time that Ghana has developed an SHS Curriculum which focuses on national values, attempting to educate a generation of Ghanaian youth who are proud of our country and can contribute effectively to its development.

This Teacher Manual for General Science is a single reference document which covers all aspects of the content, pedagogy, teaching and learning resources and assessment required to effectively teach Year Two of the new curriculum. It contains information for all 24 weeks of Year Two including the nine key assessments required for the Student Transcript Portal (STP).

Thank you for your continued efforts in teaching our children to become responsible citizens.

It is our belief that, if implemented effectively, this new curriculum will go a long way to transforming our Senior High Schools and developing Ghana so that we become a proud, prosperous and values-driven nation where our people are our greatest national asset.

# Acknowledgements

Special thanks to Professor Samuel Ofori Bekoe, Director-General of the National Council for Curriculum and Assessment (NaCCA) and all who contributed to the successful writing of the Teacher Manuals for the new Senior High School (SHS) curriculum.

The writing team was made up of the following members:

National Council for Curriculum and Assessment	
Name of Staff	Designation
Eric Amoah	Deputy Director-General, Technical Services
Reginald Quartey	Ag. Director, Curriculum Development Directorate
Anita Cordei Collison	Ag. Director, Standards, Assessment and Quality Assurance Directorate
Rebecca Abu Gariba	Ag. Director, Corporate Affairs
Anthony Sarpong	Director, Standards, Assessment and Quality Assurance Directorate
Uriah Kofi Otoo	Senior Curriculum Development Officer (Art and Design Foundation & Studio)
Nii Boye Tagoe	Senior Curriculum Development Officer (History)
Juliet Owusu-Ansah	Senior Curriculum Development Officer (Social Studies)
Ayuuba Sullivan Akudago	Senior Curriculum Development Officer (Physical Education & Health)
Godfred Asiedu Mireku	Senior Curriculum Development Officer (Mathematics)
Samuel Owusu Ansah	Senior Curriculum Development Officer (Mathematics)
Thomas Kumah Osei	Senior Curriculum Development Officer (English)
Godwin Mawunyo Kofi Senanu	Assistant Curriculum Development Officer (Economics)

National Council for Curriculum and Assessment	
Name of Staff	Designation
Joachim Kwame Honu	Principal Standards, Assessment and Quality Assurance Officer
Jephtar Adu Mensah	Senior Standards, Assessment and Quality Assurance Officer
Richard Teye	Senior Standards, Assessment and Quality Assurance Officer
Nancy Asieduwaa Gyapong	Assistant Standards, Assessment and Quality Assurance Officer
Francis Agbalenyo	Senior Research, Planning, Monitoring and Evaluation Officer
Abigail Birago Owusu	Senior Research, Planning, Monitoring and Evaluation Officer
Ebenezer Nkuah Ankamah	Senior Research, Planning, Monitoring and Evaluation Officer
Joseph Barwuah	Senior Instructional Resource Officer
Sharon Antwi-Baah	Assistant Instructional Resource Officer
Dennis Adjasi	Instructional Resource Officer
Samuel Amankwa Ogyampo	Corporate Affairs Officer
Seth Nii Nartey	Corporate Affairs Officer
Alice Abbew Donkor	National Service Person

Subject	Writer	Designation/Institution
Additional Mathematics	Dr. Nana Akosua Owusu-Ansah	University of Education Winneba
	Gershon Kwame Mantey	University of Education Winneba
	Innocent Duncan	KNUST Senior High School
Agricultural Science	David Esela Zigah	Achimota School
	Prof. J.V.K. Afun	Kwame Nkrumah University of Science and Technology
	Issah Abubakari	Half Assini Senior High School
	Mrs. Benedicta Carbilba Foli	Retired, Pope John SHS and Minor Seminary

Subject	Writer	Designation/Institution
Agriculture	Esther Fobi Donkor	University of Energy and Natural Resources, Sunyani
	Prof. Frederick Adzitey	University for Development Studies
	Eric Morgan Asante	St. Peter's Senior High School
Automotive and Metal Technology	Dr. Sherry Kwabla Amedorme	Akenten Appiah Menka University of Skills Training and Entrepreneurial Development (AAMUSTED)
	Kunquuri Philip	Kumasi Senior High Technical School
	Emmanuel Korletey	Benso Senior High Technical School
	Philip Turkson	G E S
Electrical and Electronics Technology	Walter Banuenumah	Akenten Appiah Menka University of Skills Training and Entrepreneurial Development (AAMUSTED)
	Akuffo Twumhene Frederick	Koforidua Senior High Technical School
	Gilbert Second Odjamgba	Ziavi Senior High Technical School
Building Construction and Woodwork Technology	Wisdom Dzidzienyo Adzraku	Akenten Appiah Menka University of Skills Training and Entrepreneurial Development (AAMUSTED)
	Michael Korblah Tsorgali	Akenten Appiah Menka University of Skills Training and Entrepreneurial Development (AAMUSTED)
	Dr. Prosper Mensah	CSIR-FORIG
	Isaac Buckman	Armed Forces Senior High Technical School
	Firmin Anewuoh	Presbyterian College of Education, Akropong-Akuapem
	Lavoe Daniel Kwaku	Sokode Senior High Technical School

Subject	Writer	Designation/Institution
Arabic	Dr. Mohammed Almu Mahaman	University for Development Studies
	Dr. Abas Umar Mohammed	University of Ghana
	Mahey Ibrahim Mohammed	Tijjaniya Senior High School
Art and Design Studio and Foundation	Dr. Ebenezer Acquah	University of Education Winneba
	Seyram Kojo Adipah	GES - Ga East Municipal Education Directorate
	Dr. Jectey Nyarko Mantey	Kwame Nkrumah University of Science and Technology
	Yaw Boateng Ampadu	Prempeh College
	Kwame Opoku Bonsu	Kwame Nkrumah University of Science and Technology
	Angela Owusu-Afriyie	Opoku Ware School
Aviation and Aerospace Engineering	Opoku Joel Mintah	Altair Unmanned Technologies
	David Kofi Oppong	Kwame Nkrumah University of Science and Technology
	Sam Ferdinand	Afua Kobi Ampem Girls' Senior High School
Biology	Paul Beeton Damoah	Prempeh College
	Jo Ann Naa Dei Neequaye	Nyakrom Senior High Technical School
	Abraham Kabu Otu	Prampram Senior High School
Biomedical Science	Dr. Dorothy Yakoba Agyapong	Kwame Nkrumah University of Science and Technology
	Davidson Addo	Bosomtwe Girls STEM SHS
	Jennifer Fafa Adzraku	
Business Management	Ansbert Baba Avole	Bolgatanga Senior High School
	Dr. Emmanuel Caesar Ayamba	Bolgatanga Technical University
	Faustina Graham	Ghana Education Service, HQ
Accounting	Nimako Osei Victoria	SDA Senior High School, Akyem Sekyere
	Emmanuel Kodwo Arthur	ICAG
	Bernard Adobaw	West African Examination Council

Subject	Writer	Designation/Institution
Chemistry	Awumbire Patrick Nsobila	Bolgatanga Senior High School
	Paul Michael Cudjoe	Prempeh College
	Bismark Kwame Tunu	Opoku Ware School
	Michael Amissah	St. Augustine's College
Computing and Information Communication Technology (ICT)	Raphael Dordoe Senyo	Ziavi Senior High Technical School
	Kwasi Abankwa Anokye	Ghana Education Service, SEU
	Osei Amankwa Gyampo	Wesley Girls High School, Kumasi
	Dr. Ephriam Kwaa-Aidoo	University of Education Winneba
	Dr. Gaddafi Abdul-Salaam	Kwame Nkrumah University of Science and Technology
Design and Communication Technology	Gabriel Boafo	Kwabeng Anglican Senior High Technical School
	Joseph Asomani	Akenten Appiah Menka University of Skills Training and Entrepreneurial Development (AAMUSTED)
	Phyllis Mensah	Akenten Appiah Menka University of Skills Training and Entrepreneurial Development (AAMUSTED)
Economics	Dr. Peter Anti Partey	University of Cape Coast
	Charlotte Kpogli	Ho Technical University
	Salitsi Freeman Etonam	Anlo Senior High School
Engineering	Daniel Kwesi Agbogbo	Kwabeng Anglican Senior High Technical School
	Prof. Abdul-Rahman Ahmed	Kwame Nkrumah University of Science and Technology
	Valentina Osei-Himah	Atebubu College of Education
English Language	Esther Okaitsoe Armah	Mangoase Senior High School
	Kukua Andoh Robertson	Achimota School
	Beatrice Antwiwaa Boateng	Oti Boateng Senior High School
	Perfect Quarshie	Mawuko Girls Senior High School

Subject	Writer	Designation/Institution
French	Osmanu Ibrahim	Mount Mary College of Education
	Maurice Adjetey	Retired, CREF
	Mawufemor Kwame Agorgli	Akim Asafo Senior High School
General Science	Dr. Comfort Korkor Sam	University for Development Studies
	Robert Arhin	SDA Senior High School, Akyem Sekyere
Geography	Raymond Nsiah-Asare	Methodist Girls' High School
	Prof. Ebenezer Owusu-Sekyere	University for Development Studies
	Samuel Sakyi-Addo	Achimota School
Ghanaian Languages	David Sarpei Nunoo	University of Education Winneba
	Catherine Eku Mensah	University of Cape Coast
	Ebenezer Agyemang	Opoku Ware School
Government	Josephine Akosua Gbagbo	Ngleshie Amanfro Senior High School
	Augustine Arko Blay	University of Education Winneba
	Samuel Kofi Asafua Adu	Fettehman Senior High School
History	Dr. Anitha Oforiwah Adu-Boahen	University of Education Winneba
	Prince Essiaw	Enchi College of Education
Management in Living	Grace Annagmeng Mwini	Tumu College of Education
	Dorcas Akosua Opoku	Winneba Secondary School
Clothing and Textiles	Jusinta Kwakyewaa (Rev. Sr.)	St. Francis Senior High Technical School
	Rahimatu Yakubu	Potsin T.I Ahmadiyya SHS
Food and Nutrition	Ama Achiaa - Afriyie	St. Louis SHS
	Lily-Versta Nyarko	Mancell Girls' Senior High Technical School
Literature-in-English	Blessington Dzah	Ziavi Senior High Technical School
	Juliana Akomea	Mangoase Senior High School

Subject	Writer	Designation/Institution
Manufacturing Engineering	Benjamin Atribawuni Asaaga	Kwame Nkrumah University of Science and Technology
	Dr. Samuel Boahene	Kwame Nkrumah University of Science and Technology
	Ali Morrow Fatormah	Mfantsipim School
Mathematics	Edward Dadson Mills	University of Education Winneba
	Zakaria Abubakari Sadiq	Tamale College of Education
	Collins Kofi Annan	Mando Senior High School
Music	Pros Cosmas W. K. Mereku	University of Education Winneba
	Prof. Emmanuel Obed Acquah	University of Education Winneba
	Joshua Amuah	University of Ghana
	Benjamin Ofori	CRIG Primary School, Akim Tafo
	Davies Obiri Danso	New Juaben Senior High School
Performing Arts	Dr. Latipher Amma Osei Appiah-Agyei	University of Education Winneba
	Prof. Emmanuel Obed Acquah	University of Education Winneba
	Chris Ampomah Mensah	Bolgatanga Senior High School
Core Physical Education and Health	Dr. Mary Aku Ogum	University of Cape Coast
	Paul Kofi Yesu Dadzie	Accra Academy
Elective Physical Education and Health	Sekor Gaveh	Kwabeng Anglican Senior High Technical School
	Anthonia Afosah Kwaaso	Jukwa Senior High School
Physics	Dr. Linus Kweku Labik	Kwame Nkrumah University of Science and Technology
	Henry Benyah	Wesley Girls' High School, Cape Coast
	Sylvester Affram	Kwabeng Anglican Senior High School

Subject	Writer	Designation/Institution
Christian & Islamic Religious Studies	Dr. Richardson Addai-Mununkum	University of Education Winneba
	Dr. Francis Opoku	Valley View University College
	Dr. Francis Normanyo	Mount Mary College
	Dr. Haruna Zagoon-Sayeed	University of Ghana
	Kabiru Soumana	GES
	Seth Tweneboea	University of Education Winneba
Religious and Moral Education	Anthony Mensah	Abetifi College of Education
	Joseph Bless Darkwa	Volo Community Senior High School
	Clement Nsorwineh Atigah	Tamale Senior High School
Robotics	Dr. Eliel Keelson	Kwame Nkrumah University of Science and Technology
	Isaac Nzoley	Wesley Girls' High School, Cape Coast
Social Studies	Mohammed Adam	University of Education Winneba
	Simon Tengan	Wa Senior High Technical School
	Dr. Adwoa Dufie Adjei	University Practice Senior High School
	Dr. Isaac Atta Kwenin	University of Cape Coast
Spanish	Setor Donne Novieto	University of Ghana
	Franklina Kabio-Danlebo	University of Ghana
	Mishael Annoh Acheampong	University of Media, Art and Communication
Technical Support	Benjamin Sundeme	St. Ambrose College of Education
	Dr. Isaac Amoako	Atebubu College of Education
	Eric Abban	Mt. Mary College of Education



# SECTION 1: NATURE OF DIFFERENT LIQUIDS IN LIFE

## Strand: Exploring materials

### Sub-Strand: Science and materials in nature

**Learning Outcome:** Describe the nature and uses of different liquids in the life of humans.

**Content Standard:** Demonstrate understanding of liquids in the life of humans.

#### Hint



Remind learners to create a portfolio by the end of week 3. Refer to Appendix A for sample portfolio assessment to be submitted in week 22.

Learners should be assigned a group project in week 2 to be submitted in week 5. Refer to Appendix B at the end of this section for more information on the project.

## INTRODUCTION AND SECTION SUMMARY

This section explores the fundamental concepts of acids, bases (including alkalis), and their interactions with water. It delves into applying acids and bases to form salts, an essential chemical process with numerous practical applications. A key focus is using the pH scale to identify and measure the concentration of acids and bases in various solutions. Understanding the pH scale is crucial for determining the acidity or alkalinity of substances, which has significant implications in chemistry, biology, medicine, and environmental science. Through these topics, learners will comprehensively understand acid-base reactions, pH measurement, and their practical applications in everyday life and industrial processes.

The weeks covered by the section are:

Week 1: *Differentiate among acids, bases and water.*

Week 2: *Apply the knowledge of acids and bases in analysing the formation of salts and their uses.*

Week 3: *Describe how to measure the concentration of solutions and how to use the pH scale to identify the concentration of acids and bases/alkalis.*

*Week 4: Describe how to measure the concentration of solutions and how to use the pH scale to identify the concentration of acids and bases/alkalis.*

## **SUMMARY OF PEDAGOGICAL EXEMPLARS**

This section outlines diverse pedagogical strategies for teaching acids, bases, and pH scales. Mixed-ability groups engage in collaborative research on household items to understand their acidic or basic nature, fostering peer learning and presentations. Activity-based learning involves hands-on pH testing and experiments to explore acid-base reactions. Project-based learning encourages critical analysis of acids and bases' effects on materials. Case studies link classroom concepts to real-world applications, while experiential learning emphasises practical experiments on neutralisation and salt formation. Problem-based learning and comparative analysis develop problem-solving skills and critical thinking, with learners calculating solution concentrations and evaluating pH measurement methods. Demonstrations and simulations enhance understanding through visual aids and practical practice. These varied approaches promote active learning, teamwork, and deeper comprehension of acids, bases, and the pH scale.

## **ASSESSMENT SUMMARY**

To evaluate the understanding and skills developed through these activities, multiple assessment methods will be employed. For group/collaborative learning, presentations and mini projects will be assessed on content accuracy, depth of research, and clarity of explanation. Activity-based learning will be assessed through practical experiments, with focus on correct execution, observations, and conclusions drawn. Project-based learning will involve evaluating research quality, critical analysis, and presentation skills. Case study discussions will be assessed on participation and understanding of real-world applications. Experiential learning will be assessed by observing hands-on experiments, accurate recording of results, and balanced chemical equations. Talk for learning will be evaluated through participation in discussions and comprehension of the pH concept. Hands-on activities will be assessed on correct preparation and calculation of solution concentrations. Problem-based learning will be assessed by accuracy in solving real-world scenarios. Demonstrations and comparative analysis will focus on method understanding, measurement accuracy, and analysis of strengths and limitations. Teachers can consult the Teacher Assessment Manual and Toolkits (TAMT) (NaCCA, MoE, 2003) for guidance on effectively utilising various assessment strategies.

**WEEK 1****Learning Indicators:** *Differentiate among acids, bases and water***FOCAL AREA: ACIDS, ALKALIS/BASES AND WATER****Acids**

The Latin word “acre,” which means sour, is where the word “acid” originates. When something dissolves in water and, by doing so, releases hydrogen ions ( $H^+$ ), it is known as an acid. A chemical that contributes protons or hydrogen ions to a solution is called an acid. A substance that turns red litmus paper is an acid. Plants contain certain acids and mammals can create them; these are known as organic acids.

**Table 1.1:** *lists of a few common organic acids along with their sources.*

Organic acid	Source
Formic acid	Bees (sting)
Lactic acid	Milk, Yoghurt
Citric acid	Unripe lemon and grapefruit
Palmitic acid	Palm oil
Amino acid	Eggs, meat
Acetic acid	Vinegar
Salicylic acid	Aspirin
Tartaric acid	Grapes
Ascorbic acid	Citrus fruit
Stearic acid	Shea butter, cocoa butter

Other acids are derived from minerals and are referred to as mineral or inorganic acids. Some of these are laboratory produced acids that are created chemically.

**Table 1.2:** *lists of a few significant mineral acids along with their formulas.*

Mineral / inorganic acid	Source
Hydrochloric acid (HCl)	Gastric juice in the stomach
Sulphuric acid ( $H_2SO_4$ )	Sulphur dioxide released by volcanoes and industrial processes)
Nitric acid ( $HNO_3$ )	Forms in the atmosphere during thunderstorms and is a component of acid rain
Phosphoric acid ( $H_3PO_4$ )	Present in rainwater, carbonated drinks,

## Properties of acids

### Physical properties

1. Acid solutions that are diluted taste sour.
2. Acids have a pH level less than 7
3. Many acids are corrosive.

### Chemical properties

1. Strong acids conduct electricity in aqueous solution.
2. They react with bases to form salt and water.

Example,

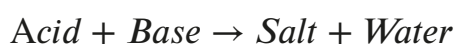
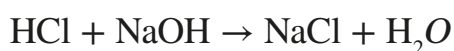

3. Dilute acids react with metallic salts (carbonates) to form salts, water, and Carbon dioxide.

Example,



4. They react with metals to produce hydrogen gas.

Example,

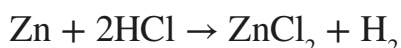

## EXPERIMENT 1.1 – Experiment to show that acid turns blue litmus paper red

**Aim:** To show that acid turns blue litmus paper red.

**Apparatus:** Blue litmus paper strips, clear plastic cups (3-4), droppers or pipettes, water, vinegar (a weak acid), lemon juice (another weak acid), baking soda solution (for comparison - optional).

### Procedure

- i. Label the cups as “vinegar,” “lemon juice,” “water,” and “baking soda”.
- ii. Pour a small amount of each liquid into its corresponding cup.
- iii. Use blue litmus paper to test each liquid in its corresponding cup.

**Observation:** Learners write their observations.

## Safety Precautions

- i. Always wear safety goggles to protect your eyes.
- ii. Handle acids with care, even weak ones. Dilute solutions are recommended.
- iii. Wash hands thoroughly after handling chemicals

## EXPERIMENT 1.2 - Experiment to show that acid is sour

**Aim:** Demonstration to show that acid tastes sour.

**Apparatus:** Test tube, water, dilute acetic acid (acquired for use in cooking), tasting spoons (one per student), litmus paper.

### Procedure

- i. Fill a test tube halfway with water after cleaning it.
- ii. Fill it with a few drops of diluted acetic acid.
- iii. Shake vigorously and use your thumb to close the test tube's mouth.
- iv. Smell the moist thumb / tasting spoons (one per student).
- v. Test the liquid using litmus paper to see if it is acidic.

**Observation:** Record the observations.

### Safety Precautions

Do not taste any chemicals in a lab setting unless instructed by your teacher. Wash hands thoroughly before and after the experiment.

**Table 1.3: Uses of acids**

Hydrochloric	Nitric	Sulphuric	Acetic
<ul style="list-style-type: none"> <li>- for cleaning rust from the surface of metals.</li> <li>- for purification of common salt (NaCl).</li> </ul>	<ul style="list-style-type: none"> <li>- in the manufacture of fertilizers like ammonium nitrate.</li> <li>- for the manufacture of explosives.</li> </ul>	<ul style="list-style-type: none"> <li>- as a dehydrating agent.</li> <li>- in manufacturing fertilizers like ammonium phosphate, Calcium ammonium phosphate, Calcium superphosphate, etc.</li> </ul>	<ul style="list-style-type: none"> <li>- in the preparation of pickles.</li> <li>- in the manufacture of synthetic fibre.</li> </ul>

Hydrochloric	Nitric	Sulphuric	Acetic
<ul style="list-style-type: none"> <li>- to make Aqua Regia (<math>3\text{HCl} + \text{HNO}_3</math>) used to dissolve noble metals such as Gold.</li> <li>- for making glucose from starch.</li> <li>- for the proper digestion of food in our stomach.</li> </ul>	<ul style="list-style-type: none"> <li>- in the manufacture of dyes, plastics and artificial silk.</li> <li>- for etching designs on metals like copper, brass and bronze.</li> </ul>	<ul style="list-style-type: none"> <li>- in manufacturing celluloid plastic, artificial silk, paints, drugs, and detergents.</li> <li>- in lead storage batteries.</li> </ul>	

Other acids are used in:

1. Petrol refinery
2. Manufacturing explosives
3. Soap making
4. Fuel in rocket
5. Food preservation
6. To remove rust.

## Bases

A base is a compound that turns red litmus paper blue and has a pH greater than 7. Bases that are soluble in water are called alkalis and can be obtained from plants' ashes. The word alkali has been taken from the Arabic word "qali", which means "from ashes".

Alkalis/bases are the compounds which produce hydroxide ions ( $\text{OH}^-$ ) in their aqueous solutions. Sodium hydroxide ( $\text{NaOH}$ ), Potassium hydroxide ( $\text{KOH}$ ), Calcium hydroxide  $\text{Ca}(\text{OH})_2$ , etc., are examples of bases/alkalis.

For example, Sodium hydroxide  $\text{NaOH}$  (aq), in its aqueous solutions, dissociates as:



**Common household bases:** ammonia, baking soda, washing soda (sodium carbonate), soap, detergents, shampoo, borax, chlorine bleach, milk of magnesia, toothpaste, egg whites, chalk, drain, cleaner, antacids and plaster.

There are two types of bases, namely organic bases and inorganic bases:

1. Organic bases occur naturally in plants and animals. They produce KOH (Potassium hydroxide). The decomposition of organic matter produces  $\text{NH}_3$  (ammonia).

Examples: petre, wood ash, cocoa peels, wasp stings.

2. Inorganic bases are bases prepared in the laboratory.

Examples: KOH (Potassium hydroxide),  $\text{NH}_4\text{OH}$  (ammonium hydroxide),  $\text{Ca}(\text{OH})_2$  (Calcium hydroxide).

## Properties

### Physical properties

1. Bases often taste bitter and are found in foods less frequently than acids. Many bases, like soaps, are slippery to the touch.
2. Bases also change the colour of indicators. Litmus turns blue in the presence of a base.

### Chemical properties

1. Bases react with acids in the neutralisation reaction of salt and water.

Example.

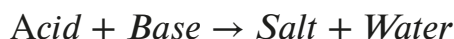
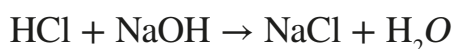

2. Bases conduct electricity when dissolved in water.
3. Bases and alkalis react with ammonium salt on heating to produce ammonium gas.

Example.

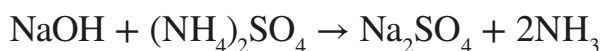

3. Bases do not react with metals like acids do.

## EXPERIMENT 1.3 – Experiment to show that bases change the colour of indicators.

**Aim:** To observe the colour change of indicators in the presence of bases.

**Apparatus:** Litmus paper, universal pH indicator solution, aqueous solutions of bases (NaOH, KOH,  $\text{NH}_4\text{OH}$ ), dropper, small containers or wells, safety goggles and gloves

### Procedure

- i. Prepare small samples of each base solution in separate containers.

- ii. Dip litmus paper into each base solution and observe the colour change. Litmus paper turns blue in the presence of bases.
- iii. Add a few drops of universal pH indicator into each base solution and observe the colour change.

**Observation:** Record and compare the colour changes observed with the indicators.

**Explanation:** Bases change the colour of indicators due to their ability to accept protons ( $H^+$  ions) and remove them from solution by creating  $H_2O$ .

**Table 1.4:** Uses of Bases / Alkalis

Household Cleaning Products	Alkalis such as Sodium hydroxide (lye) and Potassium hydroxide are key ingredients in many household cleaning products like soaps, detergents, and drain cleaners. They help to break down fats and oils through saponification and emulsification processes.
Industrial Applications	In industries, alkalis are used in the production of various chemicals. For example, Sodium hydroxide is crucial in manufacturing paper, textiles, and detergents. Potassium hydroxide is used in the production of biodiesel and pharmaceuticals.
Water Treatment	Alkalis are used to adjust water pH in both industrial processes and municipal water treatment facilities. They help neutralise acidic water and reduce its corrosive effects on pipes and equipment.
Food Industry	Alkalis, such as Sodium hydroxide, are used in food processing, particularly in chocolate and cocoa products. They help with the alkalisation process, affecting the final product's flavour and texture.
Medicine and Pharmaceuticals	Some alkalis, like Magnesium hydroxide (milk of magnesia) and Sodium bicarbonate (baking soda), are used as antacids to neutralise excess stomach acid and relieve indigestion and heartburn.
Soil Amendment	Certain alkalis, such as Calcium hydroxide (lime), are used in agriculture to adjust soil pH. This helps to optimise nutrient availability to plants and improve crop yields.

Neutralisation of Acids	Alkalis neutralise acids in various chemical processes and industrial settings. This neutralisation reaction produces water and salt, which can be easier to handle and dispose of than acidic wastes.
Environmental Applications	Alkalis are employed in environmental remediation efforts, such as neutralising acidic mine drainage and treating industrial wastewater to remove heavy metals.

## Water

### Role of water in the dissociation of acids and bases

If a dry strip of blue litmus paper is brought near the mouth of the test tube containing dry HCl gas, its colour does not change. When the paper is moistened with a drop of water and again brought near the mouth of the test tube, its colour turns red. It shows that there are no  $H^+$  ions in dry HCl gas. Only when it dissolves in water do  $H^+$  ions form.

Similar behaviour is exhibited by bases. No colour change is observed if we take a pallet of dry NaOH in a dry atmosphere and quickly bring a dry strip of red litmus paper in contact. NaOH is a hygroscopic compound that soon absorbs moisture from the air and becomes wet. When this happens, the colour of the red litmus paper immediately changes to blue. Thus, although  $OH^-$  ions are present in dry solid NaOH, they are not free (they remain stuck in the ionic lattice structure) and do not show a basic nature. When meeting water,  $OH^-$  ions become free and show the basic nature by changing red litmus blue.

From the above discussion, different substances' acidic and basic characteristics can be observed only when dissolved in water.

**Explanation:** When an acid like sulphuric acid or a base like Sodium hydroxide is dissolved in water, the solution is hotter. This shows that the dissolution process is exothermic. A part of the thermal energy released during the dissolution process is used to overcome the forces holding the hydrogen atom or hydroxyl group in the molecule of the acid or the base, breaking the chemical bond holding them and resulting in the formation of free  $H^+_{(aq)}$  and  $OH^-_{(aq)}$  ions.

### EXPERIMENT 1.4 - Experiment on the neutralisation reaction between acids and bases

**Aim:** To demonstrate the neutralisation reaction between acids and bases.

**Materials:** Dilute hydrochloric acid (HCl), aqueous solutions of bases (NaOH, KOH,  $NH_4OH$ ), pH paper or universal indicator paper, beakers, stirring rod, safety goggles and gloves

## Procedure

- i. Label three separate beakers for each base solution.
- ii. Test the pH of this solution to confirm it is basic.
- iii. Add a small amount of dilute HCl to each beaker containing a base solution.
- iv. Stir the mixture gently with a stirring rod.
- v. Test the pH of the resulting solution using pH paper or universal indicator paper.

**Observation:** Record the pH and observe any colour changes indicating neutralisation.

**Discuss:** The formation of salt and water as products of neutralisation reactions between acids and bases.

## Safety Precautions:

- i. Always wear safety goggles and gloves when handling chemicals.
- ii. Conduct experiments in a well-ventilated area or under a fume hood.
- iii. Dispose of chemical waste properly according to laboratory safety guidelines.

## EXPERIMENT 1.5 – Experiment to demonstrate that an acid solution in water conducts electricity and that a basic solution in water conducts electricity

**Aim:** Demonstrate that acidic and basic solutions in water conducts electricity.

**Apparatus:** Battery (e.g., 9V battery), two electrical wires with alligator clips or stripped ends, LED bulb (optional, for visual indication), two graphite rods or Carbon electrodes (or any conductive material like Copper wire), distilled water, acidic solution (e.g., vinegar or lemon juice), base solution (e.g., Sodium hydroxide solution or baking soda solution), light bulb holder (optional, if using a light bulb).

## Procedure

- i. Take two graphite rods (or any conductive material like copper wire) and attach wires to each rod using alligator clips or by stripping the ends of the wires and wrapping them securely around the rods.
- ii. Attach one wire from the battery (negative terminal) to one electrode (let us call this electrode A).
- iii. Attach the other wire from the battery (positive terminal) to the other electrode (electrode B).

- iv. Connect the wires via an LED bulb, a light bulb or an ammeter.
- v. Dilute your acidic solution (e.g., vinegar or lemon juice) with distilled water. The reason for a dilution is that ensures the solution is conductive but not too strong. A 1:10 dilution (acid) should work well.
- vi. Insert both electrodes (A and B) into the acid solution.
- vii. Repeat this process using pure distilled water (ensuring the electrodes have been cleaned of any acidic solution remaining on them).
- viii. Repeat this process using the base solution (ensuring the electrodes have been cleaned of any acidic solution remaining on them).

**NB:** Ensure the electrodes do not touch each other in the solution.

### Observation

- i. If the acid solution is conductive, the circuit will be complete through the solution. You can observe the following:
  - ii. LED Bulb: If an LED bulb is connected in series with the circuit, it should light up when the circuit is completed through the conductive solution.
  - iii. Light Bulb Holder: Alternatively, you can use a light bulb holder to test conductivity. Insert the light bulb into the holder and connect the circuit through the solution. If the solution conducts electricity, the light bulb should light up.
- iv. If an ammeter is used, the current reading should be recorded.
- v. Compare the results from both experiments.

### Explanation

- Ionisation of Acids: When acids (like acetic acid in vinegar) dissolve in water, they release Hydrogen ions ( $H^+$ ). These ions are responsible for carrying electric current through the solution. The flow of electricity from the battery through one electrode, the conductive acid solution, and the other completes the circuit. This flow is what causes the LED bulb to light up or the light bulb to glow.
- Ionization in Basic Solution: Basic solutions (like NaOH or  $NaHCO_3$  dissolved in water) produce hydroxide ions ( $OH^-$ ) when dissolved. These ions are responsible for conducting electric current through the solution. The visual indication of the light bulb lighting up confirms that the basic solution conducts electricity due to the presence of ions ( $OH^-$  and possibly other ions from the base) in the solution.

## Safety precautions

- i. Handle acids with care to avoid skin contact or ingestion.
- ii. Use gloves and goggles for safety.
- iii. Ensure all electrical connections are secure and the setup is stable to prevent spills or accidents.
- iv. Gases will be given off at the electrodes; ensure this experiment is well-ventilated.

**Table 1.5:** Similarities between acids and bases

Similarities	Differences
Most strong acids and bases are both corrosive. They tend to corrode or rust metals and can burn skin.	An acid changes the colour of blue litmus paper to red, and a base changes the colour of red litmus paper to blue.
Common household items are often acids or bases.	Acids donate protons, whereas bases accept them.
Both are classified based on strength, concentration, basicity and acidity	Acids are also classified based on source and the presence of Oxygen.
Acids and bases react with water.	Acids have a pH of less than 7, bases have a pH of more than 7.
Both acids and bases are electrolytes, meaning they're good conductors of electricity	Acids taste sour, bases taste bitter.
Acids and bases both produce ions in water solutions (acids release Hydrogen ions ( $H^+$ ), whereas bases release hydroxide ions ( $OH^-$ ))	
The process of mixing acid or a base in water is exothermic and releases some heat.	

## Learning Tasks

1. Identify household items that contain acids.
2. Identify examples of substances that dissolve in water.

3. Conduct a series of experiments to identify acids, bases and some of their properties.

## PEDAGOGICAL EXEMPLARS

### 1. Talk-for Learning

- a. Introduce the concept of acids and bases, giving recognisable examples of each to aid comprehension. Ask learners to participate in a class discussion whereby they suggest further examples of acids and bases and explain their justification for categorising them as such.
- b. Provide learners with a summary of the key properties of acids and bases. Learners should use this information to aid them in categorising a list of familiar substances into acids or bases.
- c. Provide scaffolding support for learners who may face challenges and assign roles such as group leader and secretary to group members. This approach promotes 21st-century skills and national core values, while also considering cross-cutting issues such as Gender Equality and Social Inclusion (GESI) and Social and Emotional Learning (SEL)

### 2. Collaborative Learning

- a. Put learners into mixed-ability groups of no more than 4 people. Assign each group a specific common household product which may be an acid or a base. Ask them to research why they are acidic or basic and how this links with their use in the household (e.g., properties, reactions, applications). Learners should produce written or oral presentations which should be shared with the class.
- b. Let learners research to explore the effects of acids and bases on common materials (e.g., metals, household items).
- c. Learners are given a table of common uses of a) acids and b) bases and use this as a scaffold to research and fill in some additional details about the specifics of how acids and bases are used in these contexts.
- d. Provide scaffolding support for learners who may face challenges and assign roles such as group leader and secretary to group members. This approach promotes 21st-century skills and national core values, while also considering cross-cutting issues such as Gender Equality and Social Inclusion (GESI) and Social and Emotional Learning (SEL)

### 3. Activity-based Learning

- a. Task learners in their groups to perform hands-on experiments or demonstrations related to acid-base reactions and water properties.
  - i. Suggested experimental procedures are outlined in the content above.

- ii. Learners should be encouraged to critique the experimental procedure and should be empowered to suggest improvements to it. More able learners could be tasked with designing their own experiments.
  - iii. Learners should be encouraged to record the results of their investigation in a coherent, systematic, and detailed manner. Where applicable they should plot data on an appropriate graph (for example, a bar graph of current against material could be plotted if an ammeter is used in experiment 5).
- b. Provide scaffolding support for learners who may face challenges and assign roles such as group leader and secretary to group members. This approach promotes 21st-century skills and national core values, while also considering cross-cutting issues such as Gender Equality and Social Inclusion (GESI) and Social and Emotional Learning (SEL)

## KEY ASSESSMENT

**Level 1:** List five household items that contain acids.

**Level 2:** In a tabular form, outline two differences between organic and inorganic acids.

**Level 3:** Describe the role of water in the dissociation of acids and bases

### Hint



The recommended mode of assessment for week 1 is **class exercise**. Use the level 2 question as a sample question.

**WEEK 2**

**Learning Indicator:** Apply the knowledge of acids and bases in analysing the formation of salts and their uses

**FOCAL AREA: APPLICATION OF ACID AND BASES IN SALT FORMATION****Salts**

A salt is a compound formed by neutralising an acid with a base. Salts are ionic compounds made of a cation other than an  $H^+$  ion and an anion other than an  $OH^-$  ion. Substances (compounds) contain acids' negative ions and bases' positive ions. A large variety of compounds exists as salts. Sodium chloride is a common salt that we use in our food. Example of Salts:

1.  $CuSO_4$  – Copper (II) Sulphate
2.  $ZnNO_3$  – Zinc (I) nitrate
3.  $NaCl$  – Sodium Chloride
4.  $K_2CO_3$  – Potassium carbonate
5.  $Fe_2(SO_4)_3$  – Iron (III) sulphate
6.  $NH_4NO_3$  – Ammonium nitrate
7.  $NaNO_3$  – Sodium nitrate
8.  $KCl$  – Potassium Chloride
9.  $KNO_3$  – Potassium nitrate
10.  $NH_4Cl$  – Ammonium Chloride
11.  $CaCl_2$  – Calcium Chloride
12.  $CaSO_4$  – Calcium sulphate
13.  $Na_2CO_3$  – Sodium carbonate
14.  $CaCO_3$  – Calcium carbonate
15.  $NaHCO_3$  – Sodium Hydrogen carbonate

**Formation of salts**

Salts are formed in many reactions involving acids and bases. The products of this reaction are typically salt and water.

## 1. By neutralisation of acids and bases

Salts are the product (besides water) of a neutralisation reaction.

### *General Equation*

The general equation for the reaction between an acid (HA) and a base (BOH) is:



For example;

Base Acid Salt Water

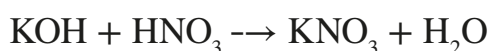
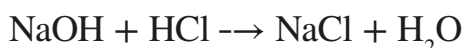

In both of the above cases, we can see that the positively charged cation of the salt comes from the base. Therefore, it is called the ‘base radical’. The negatively charged anion of the salt comes from the acid. It is, therefore, called the ‘acid radical’ of the salt.

For example, in the salt NaCl, the cation  $\text{Na}^+$  comes from the base NaOH and its basic radical, and the anion  $\text{Cl}^-$  comes from the acid HCl and is its ‘acid radical’.

## EXPERIMENT 2.1 – Experiment to show the formation of salt

**Aim:** Demonstration of salt formation

**Apparatus:** Vinegar (acetic acid solution), baking soda (Sodium bicarbonate), two clear glass or plastic cups, stirring rod or spoon, pH paper or universal indicator paper (optional, for pH testing)

### Procedure

- i. Pour a small amount of vinegar (acetic acid solution) in one cup and label A. This will act as your acid solution.
- ii. Add a small baking soda (Sodium bicarbonate) to the other cup and label B. This will act as your base.
- iii. Slowly pour the base (baking soda) into the acid solution (vinegar).
- iv. Stir the mixture gently with a stirring rod or spoon.

### Observe

Noticing bubbling or fizzing, indicating the release of Carbon dioxide gas. This is a characteristic neutralisation reaction between an acid and a base.

The mixture may also feel slightly warmer due to the exothermic nature of the neutralisation reaction.

After mixing thoroughly, you will have formed a solution containing Sodium acetate (salt), water, and carbon dioxide gas:

### Optional: pH Testing

If you have pH paper or universal indicator paper, dip it into the solution before and after the reaction to test its pH. After neutralisation, the pH should be closer to neutral (around pH 7), indicating the formation of a salt solution. The solution will not be exactly 7 unless perfectly equal molar amounts of the acid and base have been combined.

### Safety precautions

Vinegar and baking soda are generally safe household materials. However, handle them carefully to avoid spills and clean up any mess promptly.

Wear safety goggles when handling larger quantities of chemicals or if performing an experiment in a laboratory setting.

This experiment will produce CO<sub>2</sub> gas, ensure it is done in a ventilated area.

## 2. By action of acids on metals

In a reaction between an acid and a metal, salt is produced along with hydrogen.

Metal + Acid  $\rightarrow$  Salt + Hydrogen

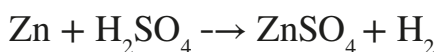

### EXPERIMENT 2.2 – Experiment to show the reaction of acids with metals

**Aim:** To show the reaction of acids with metals

**Apparatus:** A test tube, zinc granules, dilute H<sub>2</sub>SO<sub>4</sub>, matchbox and a test tube holder.

#### Procedure

- i. Add a few zinc granules to a test tube.
- ii. Add dilute sulphuric acid carefully along the sides of the test tube.
- iii. Bring a burning matchstick near the mouth of the test tube

#### Observation

When dilute sulphuric acid is added to zinc granules, hydrogen gas is formed. The gas bubbles rise through the solution.

When the burning matchstick is brought near the mouth of the test tube the gas in the test tube burns with a ‘pop’ sound. This confirms that the gas that evolved is hydrogen gas.

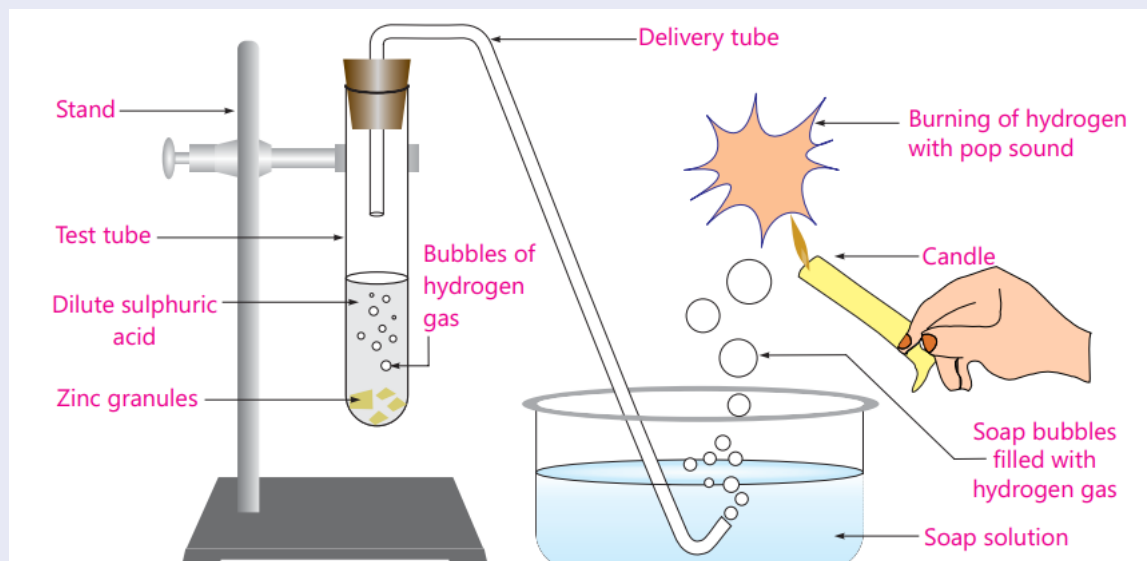
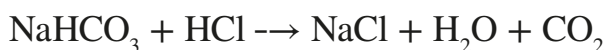
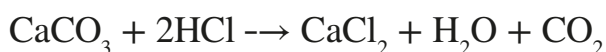

**Fig. 2.1:** Reaction between dilute sulphuric acid and Zinc

### 3. By action of acids on metal carbonates and hydrogen carbonates

Salts are produced in reactions between acids, metal carbonates, or metal hydrogen carbonates (bicarbonates) along with water and carbon dioxide.

Metal carbonate/metal Hydrogen carbonate + Acid  $\rightarrow$  Salt + water + carbon dioxide



#### EXPERIMENT 2.3 – Experiment to investigate the reaction of acids with metal carbonates and metal hydrogen carbonates

**Aim:** To study the reaction of acids with metal carbonates and metal hydrogen carbonates.

**Materials Needed:** One test tube, one boiling tube fitted with a cork, thistle funnel and delivery tube, Sodium carbonate, Sodium Hydrogen carbonate, dilute HCl and freshly prepared lime water.

#### Procedure

- i. Add about 0.5 g sodium carbonate to the boiling tube.
- ii. Take about 2 mL of freshly prepared lime water in a test tube

## Observation

- i. Observe the reaction and note the formation of bubbles ( $\text{CO}_2$  gas).
- ii. Record the formation of any gas, precipitates, or changes in the solution.

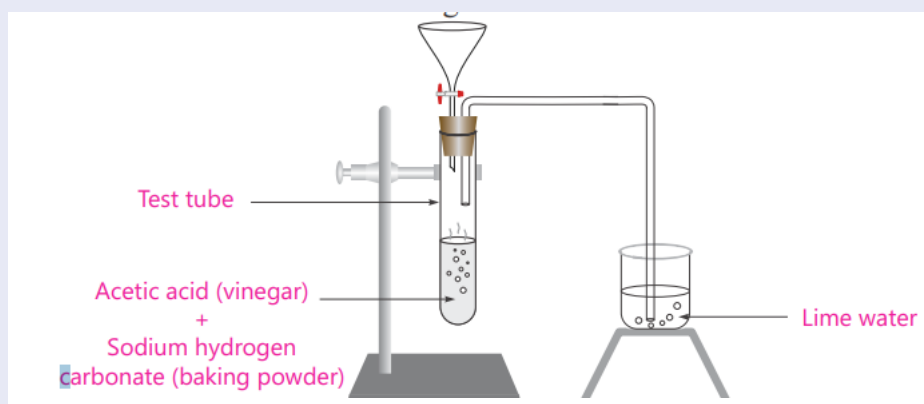

**Fig. 2.2:** Reaction of acetic acid and carbonate

## Types of Salts

**Neutral Salts:** Formed from the reaction between a strong acid and a strong base, resulting in a neutral pH.

**Acidic Salts:** Formed from the reaction between a strong acid and a weak base, resulting in a pH lower than 7.

**Basic Salts:** Formed from the reaction between a weak acid and a strong base, resulting in a pH higher than 7.

## Properties of salts

1. Salt and Water: soluble salts dissolve in water to form solutions.
2. Salt and Acids: strong acids react with salt to form salt, water and carbon dioxide.

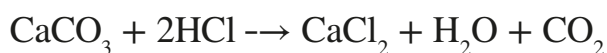

3. Salt and Alkalis: Alkalis react with salt to form salt, water and ammonia.

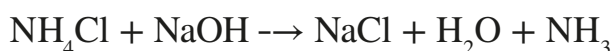

4. Action on Heat: Salts decompose on heating to form oxygen gas.

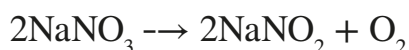

5. Neutral salts do not affect litmus paper.

**Table 2.1:** *Uses of salt*

Use	Explanation
Seasoning and flavouring	Salt is most known for its use as a seasoning to enhance the flavour of food. It is used in cooking, baking, and as a table condiment.
Preservation	Salt cures and preserves food items such as meats and fish. It draws out moisture, inhibiting bacteria growth and prolonging shelf life.
Industrial Uses	Salt is a key raw material for the chemical industry, used to produce Chlorine, Sodium hydroxide (caustic soda), and other chemicals essential for manufacturing processes.
Water Treatment	Salt is used in water softening systems to remove hardness ions (Calcium and Magnesium ions) from water, which improves its suitability for various industrial and household purposes.
Textile Industry	In dyeing and textile printing processes, salt is used as a mordant (fixative) to help dyes adhere to fibres and achieve desired colours.
Fertilisers	Salt is a component of many fertilisers, providing plants with essential nutrients such as sodium and chloride. It is particularly important for crops that require these nutrients in their growth.
Road De-icing	Winter maintenance: salt is widely used for de-icing roads and sidewalks during winter to prevent slippery conditions for pedestrians and vehicles.
Personal Care	Salt is used in various personal care products, such as bath salts and exfoliating scrubs, due to its cleansing properties. It is also used in soda acid fire extinguishers.

### Learning Task

1. State at least 3 uses of salt.
2. Describe and give an example of a neutralisation reaction.
3. Perform an experiment to demonstrate the formation of salt.

## PEDAGOGICAL EXEMPLARS

### 1. Talk-for Learning

- a. Explain the three types of reaction by which salts can form and give learners at least two examples of chemical equations demonstrating each type.
- b. Ask learners to discuss in pairs what might be meant by ‘acidic’, ‘neutral’ and ‘basic’ salts. Ask some learners to share their thoughts with the class and provide feedback to address any misconceptions.
- c. Explain the 5 properties of salts, asking the pupils to summarise these in short bullet points.

### 2. Collaborative Learning

- a. Learners working in mixed groups should be guided to research uses of salts in the home, in industry or in any other fields.
- b. Let each group present their findings to the class to the class, fostering teamwork and a deeper understanding through peer teaching.
- c. The teacher should promote discussion to enhance understanding and address any misconceptions.
- d. Provide scaffolding support for learners who may face challenges and assign roles such as group leader and secretary to group members. This approach promotes 21st-century skills and national core values, while also considering cross-cutting issues such as Gender Equality and Social Inclusion (GESI) and Social and Emotional Learning (SEL)

### 3. Activity-Based Learning

- a. Guide learners to conduct hands-on experiments (as outlined in the content above) on acids and bases to observe the properties of salt and salt formation, resulting in the production of  $\text{CO}_2$  and  $\text{H}_2$ . These gases should then be tested to confirm their presence.
- b. Encourage them to record observations, draw conclusions based on their experiments, and present their findings.
- c. Have them write balanced chemical equations for each reaction and discuss the role of acids, bases, and water. This hands-on approach reinforces theoretical concepts with practical application.
- d. Provide scaffolding support for learners who may face challenges and assign roles such as group leader and secretary to group members. This approach promotes 21st-century skills and national core values while also considering cross-cutting issues such as Gender Equality and Social Inclusion (GESI) and Social and Emotional Learning (SEL)

## KEY ASSESSMENT

**Level 1:** Define the term neutralisation reaction.

**Level 2:** Explain at least three uses of salt.

**Level 3**

1. Perform hands-on experiments to show salt formation in the laboratory.
2. Write a report on the experiment on salt formation.

### Hint



The recommended mode of assessment for week 2 is **report writing**. Use the level 3 question 2 as a sample question.

## WEEK 3

**Learning Indicator:** Describe how to measure the concentration of solutions and how to use the pH scale to identify the concentration of acids and bases/alkalis.

### FOCAL AREA: USING THE PH SCALE TO IDENTIFY THE CONCENTRATION OF ACIDS AND BASES/ALKALIS SOLUTION

The pH is defined as the hydrogen ( $H^+$ ) ion concentration of a solution (substance).

The scale used to measure the strength of the acidic or alkaline solution is known as the pH scale. A solution's pH can be found with a universal indicator, pH paper, or other specific indicators.

pH is measured on a scale of 0 to 14. The solutions with equal concentrations of Hydrogen ions ( $H^+$ ) and hydroxide ions ( $OH^-$ ) are neutral. They have  $pH = 7$ .  $pH = 7$  is the midpoint of the pH scale. The solutions with higher concentrations of Hydrogen ions will have lower than 7 pH values. The solutions with lower concentrations of Hydrogen than hydroxide ions will have greater than 7 pH values. Solutions with lower pH values are stronger acids. The solutions with higher pH values are stronger alkalis. The higher the pH value of the solutions, the higher concentration of hydroxyl ions as compared to Hydrogen ions.

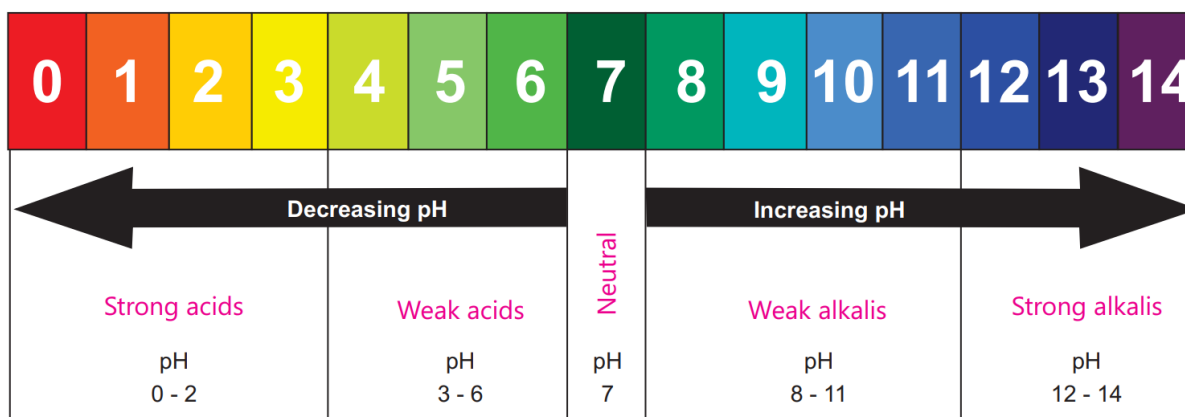

### Solutions

A solution is a homogeneous mixture of two or more substances.

**Solvent:** The component in the greatest quantity in a solution (e.g., water in saltwater).

**Solute:** The component present in a lesser quantity in a solution. It is the substance that dissolves in the solvent. (e.g., salt in saltwater)

**Gaseous solution:** A gaseous solution is a solution in which the solvent is a gas. The solute may be liquid, solid, or gas in these solutions. For example, a mixture of Oxygen

in Nitrogen gas, chloroform in Nitrogen gas, and camphor in Nitrogen gas are all gaseous solutions.

**Liquid solution:** The solution in which the solvent is a liquid is known as a liquid solution. The solute in these solutions may be gas, liquid, or solid.

For example, ethanol in water is a liquid solution, as is Oxygen dissolved in water.

**Solid solution:** A solid solution is a solution in which the solvent is a solid. The solute may be gas, liquid, or solid.

For example, a solid solution of Copper in Gold, a solution of Hydrogen in Palladium, an amalgam of Mercury with Sodium and Copper dissolved in Gold are all examples of solid solutions.

### EXPERIMENT 3.1- Preparation of a solution

Preparing solutions with a specific concentration is a fundamental skill in chemistry.

**Apparatus:** Solute (the substance being dissolved), solvent (the liquid in which the solute dissolves), balance (to measure the mass of the solute accurately), volumetric flask (a flask with a marking that indicates the final volume of the solution), graduated cylinder (to measure the solvent accurately), stirring rod or magnetic stirrer (to facilitate dissolving the solute), distilled or deionized water (recommended as solvent for most chemical solutions), safety glasses and gloves (for handling chemicals)

#### Procedure

1. Calculate the amount of solute needed:

Know the desired concentration of the solution (often expressed in molarity, mol/dm<sup>3</sup>) and the volume of solution you want to prepare (in litres, L).

Use the following formula to calculate the mass (m) of solute required:

$$m = C \times V \times M$$

Where:

m = Mass of solute in grams (g)

C = concentration of the desired solution (mol/dm<sup>3</sup>)

V = Volume of the solution in dm<sup>3</sup>

M = molar mass

NB: Molar mass of the solute in grams per mole (g/mol). See section below for **How to calculate the molar mass of a solute.**

2. Carefully weigh out the calculated mass of the solute using a balance.

3. Rinse the volumetric flask with a small amount of solvent to remove impurities.
4. Dissolve solute in a beaker using distilled water
5. Transfer the weighed solute into the volumetric flask using a funnel.
6. Add a small amount of solvent to the flask and swirl or stir gently to dissolve the solute.
7. If you used a weighing boat or other container to hold the solute, rinse it with a small amount of solvent to ensure it is transferred to the flask.
8. Gradually add distilled water to the flask, swirling constantly to ensure complete dissolution. Be careful not to fill the flask beyond the mark.
9. Wipe the outside of the flask with a clean, dry cloth to remove any solvent drips.
10. Make final adjustments to the volume:
11. Using a dropper, carefully add solvent one drop at a time until the bottom of the meniscus (the curved surface of the liquid at the top) exactly touches the graduation mark on the volumetric flask. The meniscus should be at eye level for accurate reading.
12. Secure the volumetric flask with a stopper and invert it several times to ensure homogeneous mixing of the solution.

### Precautions

1. Ensure the chosen solute is soluble in the selected solvent at the desired concentration.
2. Always wear gloves and safety glasses when handling chemicals. For specific handling precautions, refer to safety data sheets (SDS).
3. Use clean and calibrated instruments for accurate measurements.
4. Distilled water (especially for dissolving less soluble solutes) is used to improve the dissolution process.

### How to calculate the molar mass of a solute

To calculate the molar mass of a solute, you need to sum the atomic masses of all the atoms in its chemical formula.

1. Write the Chemical Formula: Identify the chemical formula of the solute.
2. Find the Atomic Mass of Each Element: Use the periodic table to find the atomic mass of each element in the compound. The atomic mass is usually given in atomic mass units (amu) or grams per mole (g/mol).

3. **Multiply the Atomic Mass by the Number of Atoms:** For each element in the compound, multiply its atomic mass by the number of atoms of that element in the formula.
4. **Sum the Total Masses:** Add the total masses of all the elements together to get the molar mass of the solute.

### Example 1

Calculate the molar mass of sodium chloride (NaCl).

1. **Chemical Formula:** NaCl
2. **Find the Atomic Masses:**
  - Sodium (Na): 23.0 g/mol
  - Chlorine (Cl): 35.5 g/mol
3. **Multiply by the Number of Atoms:**
  - Sodium:  $23.0 \text{ g/mol} \times 1 = 23.0 \text{ g/mol}$
  - Chlorine:  $35.5 \text{ g/mol} \times 1 = 35.5 \text{ g/mol}$
4. **Sum the Total Masses:**

$$\text{Molar Mass of NaCl} = 23.0 \text{ g/mol} + 35.5 \text{ g/mol} = 58.5 \text{ g/mol}$$

Hence, the molar mass of NaCl is 58.5 g/mol.

### Example 2

Calculate the molar mass of glucose ( $\text{C}_6\text{H}_{12}\text{O}_6$ )

1. **Chemical Formula:**  $\text{C}_6\text{H}_{12}\text{O}_6$
2. **Find the Atomic Masses:**
  - Carbon (C): 12.0 g/mol
  - Hydrogen (H): 1.0 g/mol
  - Oxygen (O): 16.0 g/mol
3. **Multiply by the Number of Atoms:**

$$\text{Molar Mass of } \text{C}_6\text{H}_{12}\text{O}_6$$

$$= \text{Molar Mass of } \text{C}_6\text{H}_{12}\text{O}_6 = (72.06 \times 6) \text{ g/mol} + (12.12 \times 12) \text{ g/mol} + (96.00 \times 6) \text{ g/mol}$$

$$= 180.18 \text{ g/mol}$$

Hence, the molar mass of glucose ( $\text{C}_6\text{H}_{12}\text{O}_6$ ) is 180.18 g/mol.

## Concentration of a solution

Concentration (C) is the amount of a substance in a certain volume of solution.

The composition of a solution can be described by expressing its concentration. The latter can be expressed either qualitatively or quantitatively. For example, qualitatively, we can say that the solution is dilute (i.e., a relatively very small quantity of solute) or concentrated (i.e., a relatively very large quantity of solute). But in real life, these kinds of descriptions can add to a lot of confusion and, thus, there is a need for a quantitative description of the solution. We can describe the concentration of the solution quantitatively in several ways:

**(i) Mass percentage (w/w):** The mass percentage of a component of a solution is defined as:

$$\text{Mass \% of a component} = \frac{\text{Mass of the component solution (g)}}{(\text{Total mass of the solution (g)})} \times 100$$

For example, if a solution is described as 10% glucose in water by mass, 10 g of glucose is dissolved in 90 g of water, resulting in a 100 g solution. Concentration, described by mass percentage, is commonly used in industrial chemical applications.

### Example 1

A 50.0 g NaCl is dissolved in water to make a 500 g solution. What is the percentage of NaCl in the solution?

### Solution

$$\begin{aligned} & \frac{\text{Mass of the component solution (g)}}{\text{The total mass of the solution}} \times 100 \\ &= \frac{50.0}{500.0} \times 100 \\ &= 10.0\% \text{ NaCl (w/w)} \end{aligned}$$

### Example 2

What is the mass % of NaOH in a solution prepared by dissolving 10.0 g NaOH in 100 g water?

### Solution

$$\begin{aligned} & \frac{\text{Mass of the component solution (g)}}{\text{Total mass of the solution}} \times 100 \\ &= \frac{\text{mass of solute (g)}}{\text{mass of solute (g) + mass of solvent (g)}} \times 100 \\ &= \frac{10.0}{10.0\text{g} + 100.0\text{g}} \times 100 \\ &= 9.09\% \text{ NaOH (w/w)} \end{aligned}$$

**Example 3**

Neosporin antibiotic is a 3.5% (w/w) neomycin solution. How many grams of neomycin are in 50 g of ointment?

**Solution**

$$\frac{x \text{ g}}{50.0 \text{ g}} \times 100 = 3.5$$

$$= \frac{3.5}{100} \times 50 \text{ g}$$

$$= 1.75 \text{ g neomycin}$$

**(ii) Volume percentage (v/v):** The volume percentage is defined as:

$$= \frac{\text{Volume of solute}}{\text{Total volume of the solution}} \times 100$$

For example, a 10% ethanol solution in water means that 10 mL of ethanol is dissolved in water, resulting in a total volume of 100 cm<sup>3</sup>. Solutions containing liquids are commonly expressed in this unit (note 1 mL = 1 cm<sup>3</sup>).

**Example 1**

What is the volume % of rose extract in a solution prepared by dissolving 14.0 cm<sup>3</sup> rose extract in a solvent to make 200 cm<sup>3</sup> of solution?

**Solution**

$$\frac{\text{Volume of solute}}{\text{Total volume of the solution}} \times 100$$

$$= \frac{14.0 \text{ cm}^3}{200.0 \text{ cm}^3} \times 100$$

$$= 7.0\% \text{ Rose solution (v/v)}$$

**Example 2**

What is the volume of Bromine (Br<sub>2</sub>) in 250 cm<sup>3</sup> of 4.8% v/v of Br<sub>2</sub> solution in Carbon tetrachloride?

**Solution**

$$\frac{x}{250 \text{ cm}^3} \times 100 = 4.8$$

$$x = \frac{4.8}{100} \times 250 \text{ cm}^3$$

$$= 12.0 \text{ cm}^3$$

**(iii) Mass by volume percentage (w/v):** The mass-by-volume percentage is another unit commonly used in medicine and pharmacy.

$$\text{Formula} = \frac{\text{Mass of Solute (g)}}{(\text{Volume of the solution(mL)})} \times 10$$

### Example 1

What is the mass/volume % of glucose solution prepared by dissolving 50 g glucose in enough water to make 1000 cm<sup>3</sup> of solution?

### Solution

$$\frac{\text{Mass of Solute (g)}}{\text{Volume of the solution(cm}^3)} \times 100$$

$$= \frac{50.0\text{g}}{1000 \text{ cm}^3} \times 100$$

$$= 5.0 \% \text{ glucose (w/v)}$$

### Example 2

How many grams of clindamycin antibiotics are in a 45 cm<sup>3</sup> capsule of the 1.0% (m/v) clindamycin?

### Solution

$$\frac{x}{45 \text{ cm}^3} \times 100 = 1.0$$

$$x = \frac{1}{100} \times 45 \text{ cm}^3$$

$$= 4.5 \text{ g of clindamycin}$$

### iv) Molarity (concentration in moles per dm<sup>3</sup>)

Concentration (C) expresses the moles of solute in dm<sup>3</sup> of solution. The most common solution concentration unit used in chemistry is concentration (C)

1. Determine the amount (number of moles) of solute:

If you have the mass of the solute, you can calculate the moles using the molar mass of the solute. The formula is:

$$\text{Amount of solute (n)} = \frac{\text{mass of solute(n)}}{\text{molar mass of solute(M)}}$$

2. Measure the volume of the solution:

Measure the solution's volume in dm<sup>3</sup>. If you have the volume in cm<sup>3</sup>, convert it to dm<sup>3</sup> by dividing it by 1000.

**3. Calculate the concentration:**

Use the formula to find the molarity.

$$\text{Concentration (C)} = \frac{\text{amount of solute (n)}}{\text{(Volume of solution in dm}^3 \text{ (V))}}$$

**Example 1**

Let's say you have a solution that dissolved 5 grams of Sodium Chloride (NaCl) in enough water to make a 500 cm<sup>3</sup> solution. Follow the steps to find the concentration of the solution.

**1. Calculate the number of moles of the solute**

First, find the molar mass of NaCl. Sodium (Na) has a molar mass of approximately 23 g/mol, and Chlorine (Cl) has a molar mass of approximately 35.5 g/mol.

$$\text{Molar mass of NaCl} = 23\text{g/mol} + 35.5\text{g/mol} = 58.5\text{g/mol}$$

Next, calculate the amount of NaCl in moles:

$$\text{Amount of NaCl} = \frac{\text{mass of NaCl}}{\text{molar mass of NaCl}}$$

$$\text{Amount of NaCl} = \frac{5\text{g}}{58.5\text{g/mol}}$$

$$\text{Amount of NaCl} = 0.0855\text{moles}$$

**2. Convert the volume to dm<sup>3</sup>:**

$$\begin{aligned} 500 \text{ cm}^3 &= \frac{500}{1000} \text{ dm}^3 \\ &= 0.5 \text{ dm}^3 \end{aligned}$$

**3. Calculate the concentration:**

$$C = \frac{\text{amount of solute}}{\text{Volume of solution in dm}^3}$$

$$\frac{0.0855 \text{ moles}}{0.5 \text{ dm}^3}$$

$$\text{Concentration (C)} = 0.171 \text{ mol/dm}^3$$

## Calculate the amount of substance in moles by rearranging the formula for molarity

### Example

Let us say you have a solution with a concentration of  $0.5 \text{ mol/dm}^3$  and a volume of  $250 \text{ cm}^3$ .

1. Convert the volume to  $\text{dm}^3$ :  $250 \text{ cm}^3$

$$= \frac{250}{1000} = 0.25 \text{ dm}^3$$

2. Use the formula to calculate the moles:

Amount of substance in moles = Concentration  $\times$  Volume

$$= 0.5 \text{ mol/dm}^3 \times 0.25 \text{ dm}^3$$

$$= 0.125 \text{ mol}$$

Hence, there are 0.125 moles of solute in the solution.

## EXPERIMENT 3.2 - Experiment to prepare a salt solution

**Apparatus:** Table salt (NaCl), distilled water, balance (to measure mass), volumetric flask (or a beaker and graduated cylinder), stirring rod

### Procedure

1. Calculate the Required Mass of Solute: Decide on the concentration (C) and volume (V) of the solution you want to prepare.

Use the formula:

$$n = C \times V$$

Calculate the mass using the molar mass of NaCl ( $23.0(1) + 35.5(1) = 58.5 \text{ g/mol}$ )

$$\text{Mass (g)} = \text{Moles} \times \text{Molar Mass (g/mol)}$$

**For example**, to prepare a  $0.5 \text{ mol/dm}^3$  solution of a NaCl solution:

$$n = C \times V$$

$$n = 1 \text{ mol} \times 0.5 \text{ dm}^3 = 0.5 \text{ moles}$$

$$m = n \times M$$

$$\text{Mass} = 0.5 \text{ moles} \times 58.5 \text{ g/mol} = 29.25 \text{ g}$$

2. Use the balance to measure 29.25 g of NaCl.
3. Add the NaCl to the volumetric flask or beaker.

4. Add distilled water gradually while stirring until the total volume reaches 0.5 litres.
5. Stir the solution until all the salt is completely dissolved.
6. Label the flask with the concentration and the date.

## Dilution of solution

Dilution of a solution is the addition of distilled water to decrease the solute concentration in the solution.

### EXPERIMENT 3.3 - Experiment to show the dilution of a solution

**Aim:** To dilute a stock solution

**Apparatus:** Stock solution of known concentration, distilled water, volumetric flask, pipette or burette.

#### Procedure

1. Calculate the Volume of Stock Solution Needed

Use the dilution formula:

$$C_i V_i = C_f V_f$$

Where:

$C_i$  is the concentration of the stock solution,

$V_i$  is the volume of the stock solution,

$C_f$  is the desired concentration,

$V_f$  is the final volume.

For example, to prepare 100 cm<sup>3</sup> of a 0.1 mol/dm<sup>3</sup> solution from a 1 mol/dm<sup>3</sup> stock solution:

$$C_i = 1 \text{ mol/dm}^3$$

$$V_i = ?$$

$$C_f = 0.1 \text{ mol/dm}^3$$

$$V_f = 100 \text{ cm}^3 \text{ (0.1 dm}^3\text{)}$$

$$C_i V_i = C_f V_f$$

$$V_i = C_f V_f / C_i$$

$$V_i = \frac{0.1 \times 0.1}{1}$$

$$= \frac{0.01 \text{ ML}}{1 \text{ M}} = 0.01 \text{ dm}^3$$

$$= 0.01 \times 1000 = 10 \text{ cm}^3$$

2. A 10cm<sup>3</sup> pipette or burette measures 10 cm<sup>3</sup> of the 1mol/dm<sup>3</sup> stock solution.
3. Transfer 10 cm<sup>3</sup> of the stock solution into a 100 cm<sup>3</sup> volumetric flask using a funnel.
4. Add distilled water to the flask until the total volume reaches 100 cm<sup>3</sup> mark.
5. Cap the flask and invert it several times to ensure thorough mixing.
6. Label the flask with the new concentration.

## EXPERIMENT 3.4 - Experiment to show the preparation of sugar solution

**Aim:** Prepare a sugar solution

**Apparatus:** Granulated sugar (sucrose, C<sub>12</sub>H<sub>22</sub>O<sub>11</sub>), distilled water, balance, volumetric, flask or beaker, stirring rod.

### Procedure

1. Calculate the Required Mass of Solute: Decide on the solution's molarity (M) and volume (V).
  - i. Use the molar mass of sucrose (342.3 g/mol) to calculate the mass:
  - ii. Amount substance in moles =  $M \times V$
  - iii. Mass = Moles  $\times$  Molar Mass
  - iv. For example, to prepare 1 dm<sup>3</sup> of a 0.5 mol/dm<sup>3</sup> sucrose solution:
  - v. Moles =  $0.5 \text{ mol/dm}^3 \times 1 \text{ dm}^3 = 0.5 \text{ moles}$
  - vi. Mass =  $0.5 \text{ moles} \times 342.3 \text{ g/mol} = 171.15 \text{ g}$
  - vii. Measure 171.15 g of sucrose.
2. Add the sugar to a volumetric flask or beaker. Gradually add distilled water while stirring until the total volume reaches 1 litre.
3. Stir until all the sugar is completely dissolved.
4. Label the container with the concentration and date.

### Learning Tasks

1. Describe the pH scale.
2. Prepare a salt solution.
3. Prepare a sugar solution.
4. Calculate the concentration of solutions in a variety of units.

## PEDAGOGICAL EXEMPLARS

### 1. Talk-for Learning

- a. Begin with a class discussion, using questions to prompt their thinking, for example:
  - i. What do you know about acids and bases?
  - ii. Where have you seen acids or bases being used before?
  - iii. Where have you seen acids or bases in films/TV/books/comics?
  - iv. Why is pH important in everyday life?
- b. Use visual aids, such as pH scale diagrams and videos, to illustrate the concept of the pH scale.
- c. Put learners in mixed groups to think of the definition of pH and share their views with the class for discussion. Ensure that you challenge any misconceptions and give them an accurate definition at the end.
- d. Go through worked examples of calculating concentration using the 4 different methods highlighted above. Dedicate particular time to the concept of molarity, ensuring that learners can locate the molar mass of an element and calculate the molar mass of a compound. This could be quickly formatively assessed by creating a multiple-choice quiz for learners to select the molar mass of different compounds.
- e. Provide scaffolding support for learners who may face challenges and assign roles such as group leader and secretary to group members. This approach promotes 21st-century skills and national core values, while also considering cross-cutting issues such as Gender Equality and Social Inclusion (GESI) and Social and Emotional Learning (SEL)

### 2. Activity-based Learning

- a. Organise a laboratory session where learners in mixed groups prepare solutions of different concentrations (dilute, concentrated) using laboratory techniques (see experiments outlined in content above). Provide them with instructions, equipment (beakers, pipettes), and materials (acids, bases, water) to practice proper solution preparation methods and calculations.
- b. Provide scaffolding support for learners who may face challenges and assign roles such as group leader and secretary to group members. This approach promotes 21st-century skills and national core values, while also considering cross-cutting issues such as Gender Equality and Social Inclusion (GESI) and Social and Emotional Learning (SEL)

### 3. Problem-Based Learning

- a. Present learners with real-world scenarios and mathematical problems where they need to calculate the concentration of solutions in various units (including and particularly molarity). Provide relevant data (mass, volume, molar mass) and guide learners through calculating solution concentrations independently or in small groups. Encourage critical thinking and application of mathematical concepts.
  - o Ensure that problems are differentiated such that they increase in challenge to stretch the more able learners.
- b. Provide scaffolding support for learners who may face challenges and assign roles such as group leader and secretary to group members. This approach promotes 21st-century skills and national core values, while also considering cross-cutting issues such as Gender Equality and Social Inclusion (GESI) and Social and Emotional Learning (SEL)

## KEY ASSESSMENT

**Level 1:** Explain the difference in pH between acidic and alkaline solution.

**Level 2:** With the aid of a pH scale, determine whether a solution with a pH of 4.5 is acidic or basic.

**Level 3:** Explain the steps to prepare 1 litre of a 0.5 mol/litre NaCl solution starting from solid NaCl.

**Level 4:** Describe the steps taken in an experiment to prepare 500 ml of a 0.2 mol/litre NaCl solution from solid NaCl.

### Hint



The recommended mode of assessment for week 3 is **discussion**. Use the level 1 question as a sample question.

## WEEK 4

**Learning Indicator:** Describe how to measure the concentration of solutions and how to use the pH scale to identify the concentration of acids and bases/alkalis.

### FOCAL AREA: PH MEASUREMENT

#### Importance of pH measurement

*A few examples*

- Determines nutrient availability to plants. Different plants thrive in different pH ranges; adjusting soil pH can optimise plant growth and crop yields.
- Maintaining the body's pH balance (around 7.4) is critical for metabolic processes, enzyme function, and overall health.
- Gastric pH affects digestion and nutrient absorption in the stomach.
- pH influences the taste, safety, and corrosiveness of drinking water. Optimal pH levels (around 6.5 to 8.5) ensure water is safe for consumption and plumbing systems are protected.
- pH affects food products' taste, texture, and shelf-life. pH regulation is crucial in food preservation and fermentation processes.
- To understand chemical reactions, enzyme activity, and biological processes, pH measurement is fundamental in scientific experiments and research.

#### pH paper

pH paper assesses whether a solution is acidic or basic. pH paper, or litmus paper, is a simple and inexpensive tool used to qualitatively measure a liquid solution's acidity or alkalinity (pH). It is widely used in educational settings, laboratories, and industries for quick pH assessments.

pH paper is typically made from strips or sheets of paper impregnated with natural or synthetic pH indicators. These indicators are chemical compounds that change colour in response to a solution's hydrogen ion concentration (pH). There are different types of pH paper available, depending on the range of pH values they can measure. They are:

1. **Universal Indicator Paper:** Covers a broad pH range (typically pH 1-14), using a combination of indicators that change colour at different pH levels.
2. **Specific Range Paper:** Designed to measure within a narrower pH range, such as pH 1-6 or pH 6-10, using indicators tailored to those specific ranges. Light blue litmus paper turns red under acidic conditions and red litmus paper turns blue under basic or alkaline conditions. Purple litmus paper is neutral.

## How to use pH Paper

To measure the pH of a solution, a strip of pH paper is dipped into the liquid, or a drop of the solution is placed onto the paper. Universal pH indicators change colours at different pH levels. For example:

Reddish/Pink: Indicates an acidic solution with pH values below 7.

Purple/Blue: Indicates a neutral solution with a pH of around 7.

Green/Yellow: Indicates a basic (alkaline) solution with pH values above 7.

After the pH paper has been exposed to the solution and the colour change has stabilised, it is compared against a pH colour chart (provided by the manufacturer).

### *Advantages of pH paper*

- i. Quick, easy to use.
- ii. Requires no power source.
- iii. Provides immediate results.

### *Limitations of pH paper*

- i. Provides qualitative, not quantitative, measurements.
- ii. May vary in accuracy depending on quality and type.

## EXPERIMENT 4.1 – Experiment to demonstrate the pH of the substance using pH paper

**Aim:** Demonstrate how to use pH paper to measure pH qualitatively.

**Apparatus:** vinegar, lemon juice, baking soda solution, tap water, pH paper

### **Procedure**

- i. Prepare several solutions of known pH values (e.g., vinegar, lemon juice, baking soda solution, tap water).
- ii. Dip pH paper into each solution and observe colour changes.
- iii. Use a pH colour chart to interpret the results and determine pH values.

**Observation:** Note down the pH range observed for each test solution based on the colour change of the pH paper. In a table form, record your observation.

## pH meters

A pH meter is an electronic device used to accurately and quantitatively measure the acidity or alkalinity (pH) of a liquid solution. It is a high-impedance voltmeter that measures the very small electrical potential (in millivolts [mV]) generated between a glass bulb pH electrode and a pH reference electrode. Modern meters have a digital display and typically can display pH, electromotive force (e.m.f.) in millivolts, and temperature in degrees Celsius (°C).

Some pH meters may have additional features like temperature compensation, calibration options, and data logging capabilities.

**Table 4.1:** *Types of pH meters based on Portability*

Pen testers	Pen testers are inexpensive pH meters the size of a pocketbook. They are used in the building, hydroponics, food production, and pool or spa care industries.
Handheld meters	Handheld meters often have a more robust build and a slightly larger shape than pen testers. With this design, the electrode is constructed independently of the meter. Handheld meters are designed for use in the field. Environmental officers use them in field research, aquaculture, agriculture, and water treatment.
Benchtop pH meters	The largest of the three pH meter categories are benchtop meters. They can be mounted on a wall or a desk and are often the most accurate, making them ideal for laboratory and professional use. Benchtop pH meters are frequently used in laboratories.

**Table 4.2:** *Types of pH meters based on Usage*

Laboratory pH meter	It has a large measuring range, is highly accurate, and is versatile.
Industrial pH meter	Its distinctive qualities combine analogue output, digital intelligence, and upper and lower boundary alarm and control functions, including exceptional stability, steady work, high measurement efficiency, environmental flexibility, and anti-interference capabilities.

*Types of pH meters based on reading*

Analog pH meter	An analogue pH meter is the original type of model. A pointer will show the pH level on analogue pH meters. The needle will move toward a number representing the pH level after the measuring electrode has been put into the sample. When using an analogue pH meter, one must be careful to obtain accurate findings. The little pointer is the reason for this.
Digital pH meter	Developed subsequently to analogue meters these have a numerical display or the pH value.

**Calibration of pH Meter**

pH meters need regular calibration to ensure accurate measurements.

Calibration involves adjusting the pH meter using standard pH buffer solutions (pH 4.01, pH 7.00, pH 10.01) to set accurate reference points across the pH scale.

Calibration compensates for electrode drift and ensures accurate pH readings for different solutions.

**EXPERIMENT 4.2 - Experiment to show how a pH meter is used**

**Aim:** Demonstration of how to use pH meter

**Apparatus:** pH meter (including electrodes: glass pH electrode and reference electrode), pH buffer solutions (pH 4.01, pH 7.00, pH 10.01), distilled water (for rinsing electrodes), sample, solutions to measure pH, stirring rod (if needed), cleaning cloth or tissue

**Procedure**

1. Turn on the pH Meter. If not already calibrated, perform this as follows:
  - i. Obtain pH 4.01, pH 7.00, and pH 10.01 buffer solutions.
  - ii. Check expiration dates and condition of buffer solutions to ensure accuracy.
  - iii. Rinse the pH electrode with distilled water and blot dry it with clean tissue.
  - iv. Immerse the electrode in the pH 7.00 buffer solution.
  - v. Allow the reading to stabilise (usually indicated when the display stops changing).
  - vi. Adjust the pH meter according to the manufacturer's instructions to read pH 7.00.

- vii. If necessary, rinse the electrode with distilled water and repeat the calibration process with pH 4.01 and pH 10.01 buffer solutions.
  - viii. Confirm calibration success by checking readings against buffer solution values.
2. Rinse the pH electrode with distilled water and blot dry between measurements.
  3. Stir the sample gently to ensure homogeneity (if needed).
  4. Immerse the cleaned and calibrated pH electrode into the sample solution.
  5. Allow the reading to stabilise (again, indicated when the display stops changing).
  6. Record the pH reading displayed on the pH meter.
  7. Rinse the electrode with distilled water and dry it between measurements of different solutions.

### After Use

1. Rinse the pH electrode with distilled water to remove any residue from the sample.
2. Blot dry with a clean tissue or cloth.
3. Store the pH meter with the electrode in a storage solution recommended by the manufacturer to keep it hydrated and extend electrode life.

### Safety precautions

1. Handle sample solutions and electrodes carefully to prevent spills or damage.
2. Follow laboratory safety protocols when working with chemicals and solutions.
3. Keep electrodes clean and free from debris or chemical residues.
4. pH electrodes are delicate; avoid touching sensitive parts and handle with care.
5. Regular calibration is performed to maintain accuracy, especially if the pH meter has not been used recently or after prolonged use.

**Table 4. 3:** Applications of pH Meters

Laboratory Research	Used in chemistry, biology, environmental science, and pharmaceutical research for precise pH measurements.
Industrial Processes	Monitoring and controlling pH in manufacturing processes (e.g., food and beverage production, pharmaceutical manufacturing).

Environmental Monitoring	Assessing water quality in natural ecosystems, wastewater treatment plants, and aquatic environments.
Education	Teaching and learning about pH and its importance in scientific experiments and demonstrations. Teaching and learning about pH and its importance in scientific experiments and demonstrations.

## Advantages of pH Meters

1. Provides accurate and precise quantitative pH measurements.
2. Can measure pH over a wide range (typically pH 0-14).
3. Faster and more convenient compared to qualitative methods like pH paper or pH indicators.
4. Well-matched for continuous automatic recording and control of industrial and commercial processes
5. Permits rapid and reproducible measurements.
6. Simple to control and operate.
7. Used for both oxidising and reducing solutions.
8. Does not affect the solution under examination.
9. Suitable for use in colloidal, turbid, and colourful solutions.
10. pH meters are portable, so they can be easily used everywhere while traveling.

## Limitations of pH Meter

1. pH meters should be regularly cleaned to avoid contamination of samples. When exposed to corrosive chemicals, the glass tip of the probe used in pH meters can easily break or get damaged.
2. External factors like temperature impact the pH meter's output readings. Thus, pH meters must be calibrated before use to obtain accurate results, unless the results may be distorted.
3. Deposits on electrode membranes can affect the processes.
4. A special buffer solution is needed to calibrate the pH meters.
5. Expensive compared to simpler qualitative pH testing methods.
6. Fragile electrodes may require careful handling to prevent damage.



**Fig. 4.1:** Diagram of pH meter.

## Measuring pH Using an Indicator Solution

A pH indicator is a substance (usually a liquid dye or a mixture of dyes) that changes colour in response to a change in a solution's Hydrogen ion concentration (pH). These indicators are used to visually or qualitatively determine the acidity or alkalinity of a solution based on the colour change they exhibit. They are limited because they can only be used with clear and colourless samples.

This category includes two methods

1. Comparing the standard colour corresponding to a known pH with the colour of an indicator immersed in the test liquid.
2. Preparing pH test paper soaked in the indicator, then immersing it in the test liquid and comparing its colour with the standard colour. This method is simple but prone to error. A high degree of accuracy cannot be expected.

**Table 4.4:** Types of pH Indicators

<b>Universal Indicators</b>	It can indicate a wide range of pH values (typically pH 1-14) with a spectrum of colours.
<b>Specific Indicators</b>	These indicators are designed for narrower pH ranges.

Several plants and household chemicals can be used as pH indicators, but in a lab setting, these are the most common chemicals used as indicators:

**Table 4.5:** pH indicator

Indicator	Acid Colour	Base Colour	pH Range
thymol blue (first change)	red	yellow	1.2 - 2.8
methyl orange	red	yellow	3.2 - 4.4
bromocresol green	yellow	blue	3.8 - 5.4
methyl red	yellow	Red	4.8 - 6.0
bromothymol blue	yellow	Blue	6.0 - 7.6
phenol red	yellow	Red	6.8- 8.4
thymol blue (second change)	yellow	Blue	8.0 - 9.6
phenolphthalein	colourless	Magenta	8.2 -10.0

### EXPERIMENT 4.3 - Experiment to determine the pH of substances using litmus solution

**Aim:** Using litmus solution to test for the pH of the substances

**Material:** Dilute HCl, soap solution, lemon juice, tap water, Sodium hydroxide, ammonia solution and household bleach, red litmus solution, blue litmus solution

#### Procedure

- i. Put these samples in clean test tubes and label them.
- ii. Add a few drops of red and blue litmus solution in each tube.

**Observation:** Record your observations in the following table.

Sample	Colour change		Nature of solution
	Red litmus	Blue litmus	
Dil. HCl	Remains red	Turns red	Acidic
Soap solution			
Tap water			
Sodium hydroxide			
Household bleach			

### EXPERIMENT 4.4 - Experiment to determine the pH of substances using a natural indicator

**Aim:** Using Natural indicators to test for the pH of the substances.

**Material required:** Turmeric powder, water, filter paper, different solutions

#### Procedure

- i. Make a paste of turmeric powder with water.
- ii. Apply the paste on the filter paper and allow it to dry.
- iii. Remove the dry powder from the filter paper.
- iv. Cut the filter paper into small strips.
- v. Pour different solutions separately on the strips and note the colour changes.
- vi. Record the observations in tabular form

**Observation:** Turmeric paper remains yellow in acidic and neutral solutions but turns brown in alkaline solution

### EXPERIMENT 4.5 - Experiment to determine the pH of substances using a second natural indicator

**Aim:** Using natural indicators to test for the pH of the substances.

**Material required:** Red cabbage, water, filter paper, different solutions

#### Procedure

- i. Put some chopped red cabbage in simmering water for 10 minutes.
- ii. Filter the coloured solution.
- iii. Purple coloured cabbage indicator is ready for use.
- iv. Test the sample of substances with this indicator and record the results.

**Observation:** The purple colour of the cabbage indicator turns red in acidic solutions and green in basic solutions. Neutral solutions do not change the colour of the red cabbage indicator.

## EXPERIMENT 4.6 - Experiment to determine the pH of a substance using universal indicator paper

**Aim:** Testing for pH

**Apparatus:** Universal indicator paper, dilute NaOH, dilute  $\text{NH}_4\text{OH}$ , dilute HCl, dilute  $\text{H}_2\text{SO}_4$ , vinegar, distilled water

### Procedure

- i. Take  $1\text{cm}^3$  of dilute HCl, dilute  $\text{H}_2\text{SO}_4$ , dilute  $\text{CH}_3\text{COOH}$  (vinegar), dilute NaOH distilled water in different test tubes.
- ii. Add  $1.5\text{ cm}^3$  of distilled water.
- iii. Dip separates universal indicator papers in each tube and match the colour with colour given on the strip.
- iv. Note the observations in a table form

**Table 4.6**

Sample	Colour of universal indicator paper	pH of the solution

### Learning Tasks

1. List at least three advantages of pH meters.
2. Describe how to measure pH using a meter.
3. Describe how to measure pH using an indicator.
4. Perform an experiment to determine the pH of a substance.

## PEDAGOGICAL EXEMPLARS

### 1. Talk-for Learning

- a. Introduce learners to the concept of pH measurement and briefly discuss how each type of indicator is used. Show them examples or photographs of examples where possible.
- b. Provide learners with videos to demonstrate pH measurement using a selected method (e.g., pH meter).
- c. Ask learners to discuss calibrating the pH meter, preparing samples, and recording pH readings accurately.

### 2. Experiential Learning

- a. Provide learners with samples of known (water, bottle of coca cola) and unknown pH levels to practice measuring and interpreting pH values (using the experiment outlines in the content above). Encourage discussion and troubleshooting during the practice session.
- b. Provide scaffolding support for learners who may face challenges and assign roles such as group leader and secretary to group members. This approach promotes 21st-century skills and national core values, while also considering cross-cutting issues such as Gender Equality and Social Inclusion (GESI) and Social and Emotional Learning (SEL)

### 3. Collaborative Learning

- a. Ask learners in mixed ability groups to research and compare different methods of measuring pH, such as pH paper/strips, pH meters, and indicators (e.g., universal indicator, phenolphthalein). In groups learners explain each method's principles, strengths, limitations, and applications. Allow learners to experiment with each method and analyse their accuracy and ease of use.
  - i. Learners should present their findings either as a fact sheet/poster or as an oral presentation.
  - ii. Everybody in the group should be encouraged to have a role in the generation or delivery of the presentation.
- b. Provide scaffolding support for learners who may face challenges and assign roles such as group leader and secretary to group members. This approach promotes 21st-century skills and national core values, while also considering cross-cutting issues such as Gender Equality and Social Inclusion (GESI) and Social and Emotional Learning (SEL)

## KEY ASSESSMENT

**Level 1:** Describe the pH scale and how it differentiates between alkalis, bases and neutral substances.

**Level 2:** Describe one method by which the pH of tap water could be determined.

**Level 3:** Use methyl orange and phenolphthalein to test for the pH of the substances below.

Sample	Colour change		Nature of solution
	Red litmus	blue litmus	
Dilute HCl	Remains red	Turns red	Acidic
Soap solution			
Tap water			
Sodium hydroxide			
Household bleach			

### Hint



The recommended mode of assessment for week 4 is **demonstration**. Use the level 2 question as a sample question.

## Section 1 Review

This section covered a comprehensive exploration of acids, alkalis/bases, and water over four weeks. Week one introduced the fundamentals of acids, alkalis/bases and water, emphasising their properties and applications. Week two focused on the practical application of acids and bases in salt formation, illustrating their role in chemical reactions. Week three delved into using the pH scale to quantify the concentration of acids and bases/alkalis, developing skills in pH measurement. Week four expanded on pH measurement techniques, integrating practical demonstrations and discussions on their significance in scientific analysis.

With respect to differentiation, learners engaged through various methods including collaborative projects, hands-on experiments, and discussions tailored to their learning styles. Each learner should have grasped fundamental concepts, applied them practically, and developed skills in experimental design and data interpretation. By integrating theory with application, this approach aimed to foster a deeper understanding of acids, bases, and their practical implications in everyday life and scientific contexts.

## ADDITIONAL READING

1. Investigate the pH levels of different water source.
2. Follow the links below or scan the QR codes below to watch videos

a. [https://www.youtube.com/watch?v=BYK\\_UnmGrko](https://www.youtube.com/watch?v=BYK_UnmGrko)

Scan the QR to watch video on neutralization reaction.



b. <https://www.youtube.com/watch?v=A2YyIo8vSCA>

Scan the QR code to watch video on preparation of solution



## MARKING SCHEME FOR THE DEMONSTRATION ASSESSMENT TASK

- a) Properly calibrate the pH meter using all required buffer solutions such as pH 4, 7, and 10. (1 mark)
- b) Collect tap water in a clean beaker or glass without contamination. (1 mark)
- c) Properly immerse the electrode without touching the container's sides or bottom. (1 mark)
- d) Accurately record the pH value as displayed on the digital meter. (1 mark)
- e) Rinses the electrode with distilled water after use and stores it according to guidelines. (1 mark)
- f) Demonstrates full understanding of each step and handles the pH meter with care and accuracy. (1 mark)

## MARKING SCHEME FOR THE DISCUSSION ASSESSMENT TASK

### Content/concept knowledge

- a) The difference depicts any 4 of these: Definition of pH, explain Acidic Solutions, Acidic Solutions, Comparison of pH, properly distinguish between acidic and alkaline solutions using suitable conjunctions such as “but” and “whilst” with accurate scientific terms. Accept the tabular presentation (4 marks).
- b) The difference depicts any 3 of these: Definition of pH, explain Acidic Solutions, Acidic Solutions, Comparison of pH, properly distinguish between acidic and

alkaline solutions using suitable conjunctions such as “but” and “whilst” with accurate scientific terms. Accept the tabular presentation (3 marks).

- c) The difference depicts any 2 of these: Definition of pH, explain Acidic Solutions, Comparison of pH, properly distinguish between acidic and alkaline solutions using suitable conjunctions such as “but” and “whilst” with accurate scientific terms. Accept the tabular presentation (2 marks).
- d) The difference depicts any 1 of these: Definition of pH, explain Acidic Solutions, Comparison of pH, properly distinguish between acidic and alkaline solutions using suitable conjunctions such as “but” and “whilst” with accurate scientific terms. Accept the tabular presentation (1 mark).

### Communication skills

1. Show any 4 skills, e.g., Audible voice, keeping eye contact with class members, paying attention to the audience, and the ability to ask relevant questions to ensure understanding, keep the discussion focused, and engage the audience through interaction. (4 marks).
2. Show any 3 skills, e.g., Audible voice, keeping eye contact with class members, paying attention to the audience, Ability to ask relevant questions to ensure understanding, keeping the discussion focused, and engaging the audience with interaction. (3 marks).
3. Show any 2 of the skills, e.g., Audible voice, keeping eye contact with class members, paying attention to the audience, Ability to ask relevant questions to ensure understanding, keeping the discussion focused, and engaging the audience with interaction (2 marks).
4. Show any 1 of the skills e.g. Audible voice, keeping eye contact with class members, paying attention to the audience, asking relevant questions to ensure understanding, keeping the discussion focused and engaging the audience with interaction. (1 mark).

### Collaboration and teamwork

1. Stating any 4 of these: Flexibility in adjusting to changing roles, tasks, or team dynamics, Skill in addressing disagreements calmly and finding mutually acceptable solutions, valuing different backgrounds, experiences, and opinions, fostering an inclusive and supportive team environment. (4 marks)
2. Stating any 4 of these: Flexibility in adjusting to changing roles, tasks, or team dynamics, Skill in addressing disagreements calmly and finding mutually acceptable solutions, valuing different backgrounds, experiences, and opinions, fostering an inclusive and supportive team environment. (3 marks)
3. Stating any 4 of these: Flexibility in adjusting to changing roles, tasks, or team dynamics, Skill in addressing disagreements calmly and finding mutually acceptable

solutions, valuing different backgrounds, experiences, and opinions, fostering an inclusive and supportive team environment. (2 marks)

4. Stating any 4 of these: Flexibility in adjusting to changing roles, tasks, or team dynamics, Skill in addressing disagreements calmly and finding mutually acceptable solutions, valuing different backgrounds, experiences, and opinions, fostering an inclusive and supportive team environment. (1 marks)

## MARKING SCHEME FOR THE CLASS EXERCISE ASSESSMENT TASK

Organic acid	Inorganic acid
Contains carbon (C) and often hydrogen (H) in its molecular structure.	Do not contain carbon-hydrogen bonds.

- a) Two differences were accurately identified with the appropriate use of terms such as “carbon-containing,” “pKa,” and “molecular structure.” (2 marks each)
- b) Information is well-organized in a table. (1 mark each)

Total – 10 marks



## APPENDIX A: INDIVIDUAL PORTFOLIO FOR LEARNERS' ACADEMIC ACHIEVEMENTS

### Portfolio Task

1. Assemble selected artefacts from weeks 1 - 22 weeks of the academic year to create a comprehensive portfolio showcasing your student growth and teamwork over the year.
2. This portfolio should be submitted at the end of week 23 of the second semester, scored and recorded.

### Portfolio Artefacts (materials)

1. Summary of your Integrated science philosophy
2. Assignments (copies)
  - a) Classwork
  - b) Case study
  - c) Homework
  - d) Presentation/Poster
3. Examination (copies)
  - a) Mid-semester exams (semester 1 and 2)
  - b) End-of-semester exams
4. Project works (copies)
  - a) Group project
  - b) Individual project work
5. Reports on (copies)
  - a) Experiment
  - b) Field trip
6. Student reflection

### Organisation of the portfolio

The following elements should be present in a file containing all collected items:

- a) Subject name, Full name, Class, and Academic Year (e.g., 2024/2025 Academic Year) on the cover page.
- b) A succinct 100 words for each student reflection and integrated science philosophy
- c) A glossary with new terms learned this year on the final page.

## How to Administer

- a) Collect evidence related to the outcomes being assessed.
- b) Select the best evidence and label each piece according to the learning outcome.
- c) Guide learners in writing a one—or two-page reflective essay/memo that explains why they selected the examples, how the pieces demonstrate their achievement of the program outcomes, and/or how their knowledge/ability/attitude changed.
- d) Guided on how to format requirements (e.g., type of binder, font and style
- e) guide requirements, online submission requirements).
- f) Given submission (and pickup) dates and instructions.
- g) Explain the purpose and the submission date and provide clear instructions on how the portfolio structure will be completed for learners, etc.

Refer to Teacher Assessment Manual and Toolkits, pages 22-24, for more information on how to administer class assignment.

## Rubrics for scoring E.g.

Teachers should give appropriate marks to reflect the demands of the criteria below.

### 1. Cover page (5 marks)

The cover page should include

- a) the title, student name, subject, school name, date, and other required information. (5 marks)
- b) the title, student name, subject, school name and date. (3 marks)
- c) the title, student name, subject, and school name. (2 marks)
- d) the student's name, subject, school name, and date. (1 marks) Presentation of cover (1 marks)

The cover page is well-organised, legible, and professionally presented, with appropriate formatting. (1 marks)

### 2. Table of contents (3 marks)

- a) The table of contents accurately reflects the content and structure of the document, with correct page numbers. (3 marks)
- b) The table of contents follows a consistent and appropriate format, including headings, subheadings, and page alignment. (1 marks)

### 3. Integrated science philosophy (5 marks)

- a) The philosophy is articulated, demonstrating a deep understanding of nature and purpose that is directly relevant to integrated science. (5 marks)

- b) The philosophy is articulated, demonstrating a deep understanding of nature and the purpose of integrated science. (3 marks)
  - c) The philosophy is articulated, demonstrating a deep understanding of the nature of integrated science. (2 marks)
  - d) The philosophy reflects creative, critical thinking and an insightful understanding of how science can be integrated with areas of life. (2 marks)
4. Completeness of artefacts (15 marks)
- a. Project (posters, photo images, etc.)
  - b. Laboratory reports
  - c. Research reports
  - d. Assignments (homework and class work)
  - e. Group works (simulation records)
  - f. Mid-semester exams
  - g. End of first term exam
5. Completeness
- a) All required artefacts are present and properly included in the portfolio. (10 marks)
  - b) Most artefacts are present, but a few are missing. (7 marks)
  - c) Several artefacts are missing. (2 marks)
6. Presentation and Neatness
- a) Well-prepared, neatly presented, clearly labelled, easy to navigate and show high effort and thought. (5 marks)
  - b) Presentable but may lack neatness and organisation, and there may be minor issues with labelling or flow. (2 marks)
7. Student reflection (6 marks)
- a) The student demonstrates a thorough understanding of their learning process. They show critical thinking by evaluating both their strengths and areas of improvement. (4 marks)
  - b) The student clearly explains how the experience helped them meet or fail to meet the goals of the project or assignment. (2 marks)
  - c) The student includes specific examples or situations that illustrate their points. (1 marks)
8. A glossary on the last page with new terminologies (4 marks)

**9. Feedback**

- a)** Give periodic prompts during your lessons to remind learners what they must do at every stage of their portfolio-building
- b)** Clearly establish the criteria for consistently evaluating/scoring.
- c)** Mark and record learners' performances
- d)** Reflect on the activity and learner performances
- e)** Identify learners with SEN who may need extra support, etc.

### Rubrics for the Report Writing Assessment Task

Criteria	Excellent (4)	Very Good (3)	Good (2)	Needs Improvement (1)
Introduction	<p>The introduction depicts any 4 of these; <b>Background Information:</b> Explain the scientific concept of salt formation (e.g., reaction between acids and bases, neutralisation).</p> <p><b>Purpose of the Experiment:</b> State why the experiment is being conducted.</p> <p><b>Hypothesis:</b> Clearly outline the expected outcome or scientific prediction.</p> <p><b>Relevance:</b> Explain the practical or theoretical importance of salt formation.</p>	<p>The introduction depicts any 3 of these; <b>Background Information:</b> Explain the scientific concept of salt formation (e.g., reaction between acids and bases, neutralisation).</p> <p><b>Purpose of the Experiment:</b> State why the experiment is being conducted.</p> <p><b>Hypothesis:</b> Clearly outline the expected outcome or scientific prediction.</p>	<p>The introduction depicts any 2 of these; <b>Background Information:</b> Explain the scientific concept of salt formation (e.g., reaction between acids and bases, neutralisation).</p> <p><b>Purpose of the Experiment:</b> State why the experiment is being conducted.</p>	<p>The introduction depicts any 1 of these; <b>Background Information:</b> Explain the scientific concept of salt formation (e.g., reaction between acids and bases, neutralisation).</p>

Criteria	Excellent (4)	Very Good (3)	Good (2)	Needs Improvement (1)
Materials	<p>Stating 2 each of the materials list. E.g.</p> <p><b>Equipment</b></p> <p>Beakers (100 mL, 250 mL), Measuring cylinders (10 mL, 50 mL), Bunsen burner (or heating plate), Evaporating dish, Tripod stand and wire gauze, Thermometer, Glass stirring, rod, Funnel, Filter paper, Tongs.</p>	<p>stating 1 each of the materials list. E.g.</p> <p><b>Equipment</b></p> <p>Beakers (100 mL, 250 mL), Measuring cylinders (10 mL, 50 mL), Bunsen burner (or heating plate), Evaporating dish, Tripod stand and wire gauze, Thermometer, Glass stirring, rod, Funnel, Filter paper, Tongs.</p>	<p>stating 4 of the materials list. E.g.</p> <p><b>Equipment</b></p> <p>Beakers (100 mL, 250 mL), Measuring cylinders (10 mL, 50 mL), Bunsen burner (or heating plate), Evaporating dish, Tripod stand and wire gauze, Thermometer, Glass stirring, rod, Funnel, Filter paper, Tongs.</p>	<p>stating 2 of the materials list. E.g.</p> <p><b>Equipment</b></p> <p>Beakers (100 mL, 250 mL), Measuring cylinders (10 mL, 50 mL), Bunsen burner (or heating plate), Evaporating dish, Tripod stand and wire gauze, Thermometer, Glass stirring, rod, Funnel, Filter paper, Tongs.</p>
	<p><b>Chemicals</b></p> <p>Hydrochloric acid (HCl), Sodium hydroxide (NaOH) solution, Distilled water.</p>	<p><b>Chemicals</b></p> <p>Hydrochloric acid (HCl), Sodium hydroxide (NaOH) solution, Distilled water.</p>	<p><b>Chemicals</b></p> <p>Hydrochloric acid (HCl), Sodium hydroxide (NaOH) solution, Distilled water.</p>	<p><b>Chemicals</b></p> <p>Hydrochloric acid (HCl), Sodium hydroxide (NaOH) solution, Distilled water.</p>
	<p><b>Tools</b></p> <p>pH indicator (e.g., litmus paper or universal indicator solution), Dropper or pipette, Spatula,</p>	<p><b>Tools</b></p> <p>pH indicator (e.g., litmus paper or universal indicator solution), Dropper or pipette, Spatula,</p>	<p><b>Tools</b></p> <p>pH indicator (e.g., litmus paper or universal indicator solution), Dropper or pipette, Spatula,</p>	<p><b>Tools</b></p> <p>pH indicator (e.g., litmus paper or universal indicator solution), Dropper or pipette, Spatula,</p>

Criteria	Excellent (4)	Very Good (3)	Good (2)	Needs Improvement (1)
	<p><b>Safety Equipment</b> Safety goggles, Lab coat, Gloves.</p>	<p><b>Safety Equipment</b> Safety goggles, Lab coat, Gloves.</p>	<p><b>Safety Equipment</b> Safety goggles, Lab coat, Gloves.</p>	<p><b>Safety Equipment</b> Safety goggles, Lab coat, Gloves.</p>
Methods	<p>Stating any 4 of these: measuring the Reactants, Titration Process (Neutralization), Evaporation to Obtain Salt</p>	<p>Stating any 3 of these: measuring the Reactants, Titration Process (Neutralization), Evaporation to Obtain Salt</p>	<p>Stating any 2 of these: measuring the Reactants, Titration Process (Neutralization), Evaporation to Obtain Salt</p>	<p>Stating any 1 of these: measuring the Reactants, Titration Process (Neutralization), Evaporation to Obtain Salt</p>
Results	<p>Explaining any 3 of these: <b>Observations:</b> Qualitative data, such as changes in colour, texture, or state. <b>Measurements:</b> Quantitative data, such as temperature changes, masses, or volumes. <b>Presentation of Data:</b> Tables/ charts/ or graphs with proper labels (titles, axes, units).</p>	<p>Explaining any 2 of these: <b>Observations:</b> Qualitative data, such as changes in colour, texture, or state. <b>Measurements:</b> Quantitative data, such as temperature changes, masses, or volumes. <b>Presentation of Data:</b> Tables/ charts/ or graphs with proper labels (titles, axes, units).</p>	<p>Explaining any 1 of these: <b>Observations:</b> Qualitative data, such as changes in colour, texture, or state. <b>Measurements:</b> Quantitative data, such as temperature changes, masses, or volumes. <b>Presentation of Data:</b> Tables/ charts/ or graphs with proper labels (titles, axes, units).</p>	<p>stating any 2 of these: changes in colour, texture, or state, temperature changes, masses, or volumes, Tables/ charts/ or graphs with proper labels (titles, axes, units).</p>

Criteria	Excellent (4)	Very Good (3)	Good (2)	Needs Improvement (1)
Discussion	<p>Stating any 4 of these:</p> <p><b>Analysis of Results:</b> Explain whether the hypothesis was supported or not.</p> <p><b>Scientific Explanation:</b> Link the results to scientific principles (e.g., neutralization reactions).</p> <p><b>Limitations:</b> Acknowledge any factors that could have influenced the results (e.g., measurement errors).</p> <p><b>Suggestions for Improvement:</b> Propose ways to improve the experiment.</p>	<p>Stating any 3 of these:</p> <p><b>Analysis of Results:</b> Explain whether the hypothesis was supported or not.</p> <p><b>Scientific Explanation:</b> Link the results to scientific principles (e.g., neutralization reactions).</p> <p><b>Limitations:</b> Acknowledge any factors that could have influenced the results (e.g., measurement errors).</p> <p><b>Suggestions for Improvement:</b> Propose ways to improve the experiment.</p>	<p>Stating any 2 of these:</p> <p><b>Analysis of Results:</b> Explain whether the hypothesis was supported or not.</p> <p><b>Scientific Explanation:</b> Link the results to scientific principles (e.g., neutralization reactions).</p> <p><b>Limitations:</b> Acknowledge any factors that could have influenced the results (e.g., measurement errors).</p> <p><b>Suggestions for Improvement:</b> Propose ways to improve the experiment.</p>	<p>Stating any 1 of these:</p> <p><b>Analysis of Results:</b> Explain whether the hypothesis was supported or not.</p> <p><b>Scientific Explanation:</b> Link the results to scientific principles (e.g., neutralization reactions).</p> <p><b>Limitations:</b> Acknowledge any factors that could have influenced the results (e.g., measurement errors).</p> <p><b>Suggestions for Improvement:</b> Propose ways to improve the experiment.</p>

Criteria	Excellent (4)	Very Good (3)	Good (2)	Needs Improvement (1)
Conclusion	<p>Explaining any 3 of these: <b>Summary of Key Results:</b> Concisely restate the main findings.</p> <p><b>Link to Purpose and Hypothesis:</b> Indicate whether the experiment met its objective and validated or refuted the hypothesis.</p> <p><b>Takeaway Message:</b> Highlight the broader implications of the results.</p>	<p>Explaining any 2 of these: <b>Summary of Key Results:</b> Concisely restate the main findings.</p> <p><b>Link to Purpose and Hypothesis:</b> Indicate whether the experiment met its objective and validated or refuted the hypothesis.</p> <p><b>Takeaway Message:</b> Highlight the broader implications of the results.</p>	<p>Explaining any 1 of these: <b>Summary of Key Results:</b> Concisely restate the main findings.</p> <p><b>Link to Purpose and Hypothesis:</b> Indicate whether the experiment met its objective and validated or refuted the hypothesis.</p> <p><b>Takeaway Message:</b> Highlight the broader implications of the results.</p>	<p>stating any 2 of these: <b>Summary of Key Results:</b> Concisely restate the main findings.</p> <p><b>Link to Purpose and Hypothesis:</b> Indicate whether the experiment met its objective and validated or refuted the hypothesis.</p> <p><b>Takeaway Message:</b> Highlight the broader implications of the results.</p>



## APPENDIX B: GROUP PROJECT ON CONCEPT MAP

**Task:** Research the key metabolic waste organs involved in excretion. Organise the research information visually by creating a concept map that shows the relationships between excretory organs and metabolic waste products.

### Organisation

- Cover page: Subject name, Full name, Class, Title, and Academic Year (for example, 2024/2025).
- Create the Concept Map based on introducing excretion and metabolic waste products and analysing the excretion process in different organs.

### How to administer

Provide clear guidelines for developing the project and assessing it.

Provide and use ongoing feedback and guidance to learners.

Refer to Teacher Assessment Manual and Toolkits, pages 27-29, for more information on how to administer report writing.

### Rubrics

*Content Accuracy* (8 marks)

- Stating the central theme, such as excretion, and placed at the centre of the workspace = (3 marks)
- Stating the central theme, such as excretion (1 mark)

*Branch* (5 marks)

- All five organs, such as kidneys, liver, lung, skin, and large intestine, are accurately represented with no errors in spelling. (5 marks)
- Four organs, such as kidneys, liver, lung, skin, large intestine and processes, are accurately represented with no errors in spelling. (3 marks)
- Three organs, such as kidneys, liver, lung, skin, large intestine and processes, are accurately represented with no errors in spelling. (2 marks)
- Two organs, such as kidneys, liver, lung, skin, large intestine and processes, are accurately represented with no errors in spelling. (1 mark)

*Organisation and Structure* (11 marks)

- Arrange concepts such as kidneys, liver, lung, skin, and large intestine around the central theme in a way that makes logical sense (e.g., by importance or function). (5 marks)
- Drawn lines between related concepts to show how they are connected. (2 marks)

- c) Labelled lines with words or phrases that describe the relationship such as Kidney → Filtration, Liver → Detoxification (2 marks)
- d) Under each key concept, add more detailed sub-concepts with accurate information such as “Kidney,” → Filters blood (2 marks)
- e) Creativity and Visual Appeal (5 marks)
- f) Highly creative and visually appealing; design elements greatly enhance understanding. (5 marks)
- g) Visually appealing with some creativity; design elements support understanding. (3 marks)
- h) Basic visual appeal; limited creativity; some design elements detract from understanding. (2 marks)
- i) Lacks creativity and visual appeal; design elements make the map difficult to understand. (1 marks)

*Group Collaboration and Contribution* (5 marks)

- Stating any 4 of these: Respecting the views of others, tolerating others, resolving conflicts and taking responsibility
- Stating any 3 of these: Respecting the views of others, tolerating others, resolving conflicts and taking responsibility
- Stating any 2 of these; Respecting the views of others, tolerating others, resolving conflicts and taking responsibility
- Stating any 1 of these; Respecting the views of others, tolerating others, resolving conflicts and taking responsibility

*Presentation* (4 marks)

- a) The concept map is neat, easy to read, and free of spelling errors of any 4 of these: arrows that draw attention to key points. Visuals are eye-catching and relevant and enhance understanding of the content. Text and images are balanced and easy to follow.
- b) The concept map is neat, easy to read, and free of spelling errors of any 3 of these: arrows that draw attention to key points. Visuals are eye-catching and relevant and enhance understanding of the content. Text and images are balanced and easy to follow.
- c) The concept map is neat, easy to read, and free of spelling errors of any 2 of these: arrows that draw attention to key points. Visuals are eye-catching and relevant and enhance understanding of the content. Text and images are balanced and easy to follow.

- d) The concept map is neat, easy to read, and free of spelling errors of any 1 of these: arrows that draw attention to key points. Visuals are eye-catching and relevant and enhance understanding of the content. Text and images are balanced and easy to follow.
- e) A glossary on the last page on new terminologies learnt

### **Feedback**

Guide learners in reflecting on their project-based assessments and help them develop metacognitive skills, etc.

# SECTION 2: HUMAN EXCRETORY ORGANS

## Strand: Processes for living

### Sub-strand: Essentials for survival

**Learning Outcome:** Model and describe the structure and function of the human body parts responsible for removing waste.

**Content Standard:** Demonstrate an understanding of how waste substances are removed from the human body.

#### Hint



Remind learners of Mid-Semester examination in week 6. Refer to the Appendix D for more sample task and the Table of Specification.

## INTRODUCTION AND SECTION SUMMARY

The excretory system plays a crucial role in maintaining the body's internal balance by eliminating waste products and regulating water and electrolyte levels. This section covers an in-depth analysis of the structure and function of the excretory organs, the processes involved in waste removal, and the evaluation of disorders affecting the excretory system.

By the end of this section, learners will gain a thorough understanding of the excretory system's structure and function, the critical processes involved in waste removal, and the potential disorders that can impair this system. This knowledge will form a solid foundation for recognising the significance of maintaining a healthy excretory system.

The weeks covered by the section are:

Week 5: *Analyse the structure and function of the excretory organs in the human body.*

Week 6: *Analyse the structure and function of the excretory organs in the human body.*

Week 7: *Describe the processes for the removal of waste from the human body.*

Week 8: *Describe the processes for the removal of waste from the human body.*

Week 9: *Evaluate disorders of the human excretory organ system.*

## SUMMARY OF PEDAGOGICAL EXEMPLARS

This section offers a variety of interactive and project-based learning activities to deepen learners' understanding of the excretory system. Learners work in mixed groups to explore excretion using books and the internet, creating concept maps, models, and posters to illustrate key concepts. Activities include using anatomy models and virtual simulations to identify excretory organs, hands-on projects like skin models, and guided inquiries into kidney and liver functions. Dissections and collaborative discussions enhance comprehension of anatomical features. Learners present their findings through presentations, posters, and multimedia projects, culminating in gallery walks and exhibitions for peer review and feedback. This approach promotes active engagement, inquiry-based learning, and collaborative exploration of the excretory processes, emphasising the roles of the kidneys, liver, lungs, skin, and large intestine in waste removal and homeostasis.

## ASSESSMENT SUMMARY

Assessments within this framework encompass formative, summative, and differentiated approaches to evaluate student learning comprehensively. Formative assessments encompass activities like lab work, short tests, group projects, and presentations to enhance science process skills and gauge understanding. Conversely, summative assessments are conducted at the end of the lesson, section, or semester, contributing to cumulative records. Learners can self-assess learning outcomes by coding them red (not understood), amber (partially understood), or green (well understood). This system aids in tracking progress and addressing areas for improvement effectively.

Creating a conducive assessment environment entail providing clear instructions and maintaining consistency for all participants to uphold fairness. Emphasising the application of knowledge, critical thinking, problem-solving, and effective communication in assessments ensures a holistic evaluation of learners' aptitudes. Differentiated assessments cater to individual learner needs, with gifted learners receiving challenging tasks, enriching activities, or accelerated learning options and foster 21<sup>st</sup> century skills. Transcript recording is vital to document learner characteristics, assessment details, and additional observations for a comprehensive evaluation overview.

Tailoring assessments to accommodate diverse learning needs, strengths, and interests ensures that all learners can showcase their skills equally. By adapting assessment content to various readiness levels and preferences, teachers should foster an inclusive learning environment that nurtures each student's capabilities to their fullest potential.

Teachers can consult the Teacher Assessment Manual and Toolkits (TAMT) (NaCCA, MoE, 2003) for guidance on effectively utilising various assessment strategies.

## WEEK 5

**Learning Indicator:** Analyse the structure and function of the excretory organs in the human body.

## FOCAL AREA: UNDERSTANDING THE STRUCTURE AND FUNCTION OF HUMAN EXCRETORY ORGANS

### Overview of Excretory system

The liver, skin, lungs, large intestine, and kidneys are the excretory organs in the human body. Together, these organs form the human excretory system. Different organisms have different products of excretion based on their environment and lifestyle. These organs work with the circulatory, nervous, and endocrine systems to keep the body's internal environment constant. In other words, these organ systems maintain homeostasis.

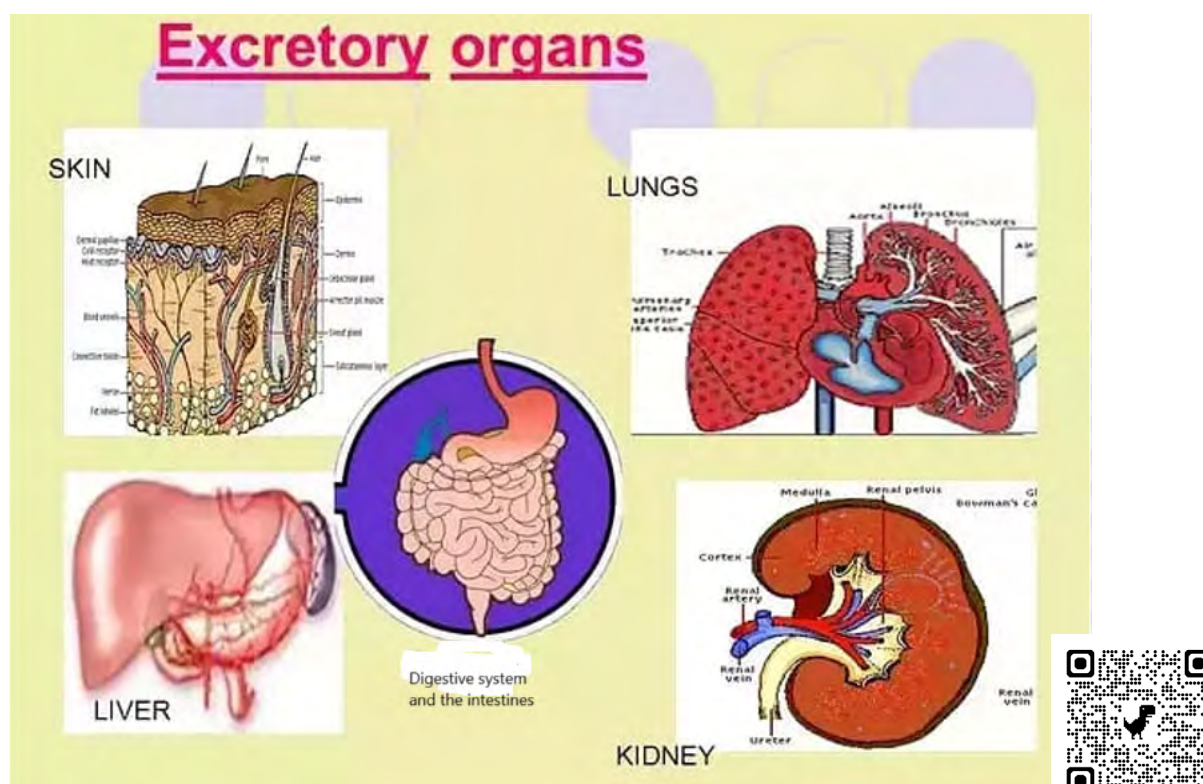

**Fig. 5 1:** diagram of excretory organs

### Definition of Excretion

Excretion is a biological process in which an organism removes the metabolic waste from its body. The body removes by-products of metabolism and poisonous substances, controls the water level of the body, controls the pH of the blood and the ionic concentration of blood fluid. In the human body, the liver, skin, lungs, large intestine, and kidneys are the excretory organs. Some of the waste products removed from the human body contain

Carbon dioxide from cellular respiration, urea from protein, ammonia, uric acid from nucleic acid, and bilirubin.

## Identification of Excretory organs and their excretory function

**Table 5.1:** shows excretory organs and their excretory products

Excretory organ	Excretory products
Skin	Urea, lactic acid, excess salts, and excess water in the form of sweat.
Kidney	Excess salts, excess water, and nitrogenous in the form of urine.
Lungs	Carbon dioxide and excess water in the form of water vapour.
Liver	Bile pigments
	Nitrogenous waste include ammonia, uric acid, urea, and trimethylamine oxide.
Large intestine	Bilirubin

**The structure and the function of the skin (N.B. Care should be taken here to ensure any learners with skin diseases/conditions are notified of this topic in advance as it may cause distress)**

The skin provides a protective covering throughout our body and acts as the body's initial barrier against external harmful substances or foreign particles. Hair is made up of a protein called keratin, and the same protein is found in the hooves, horns, claws, and nails of other animals, too.

The structure of the skin is made up of three layers of, namely: epidermis, dermis and hypodermis (labelled as the “fat layer” in the diagram below).

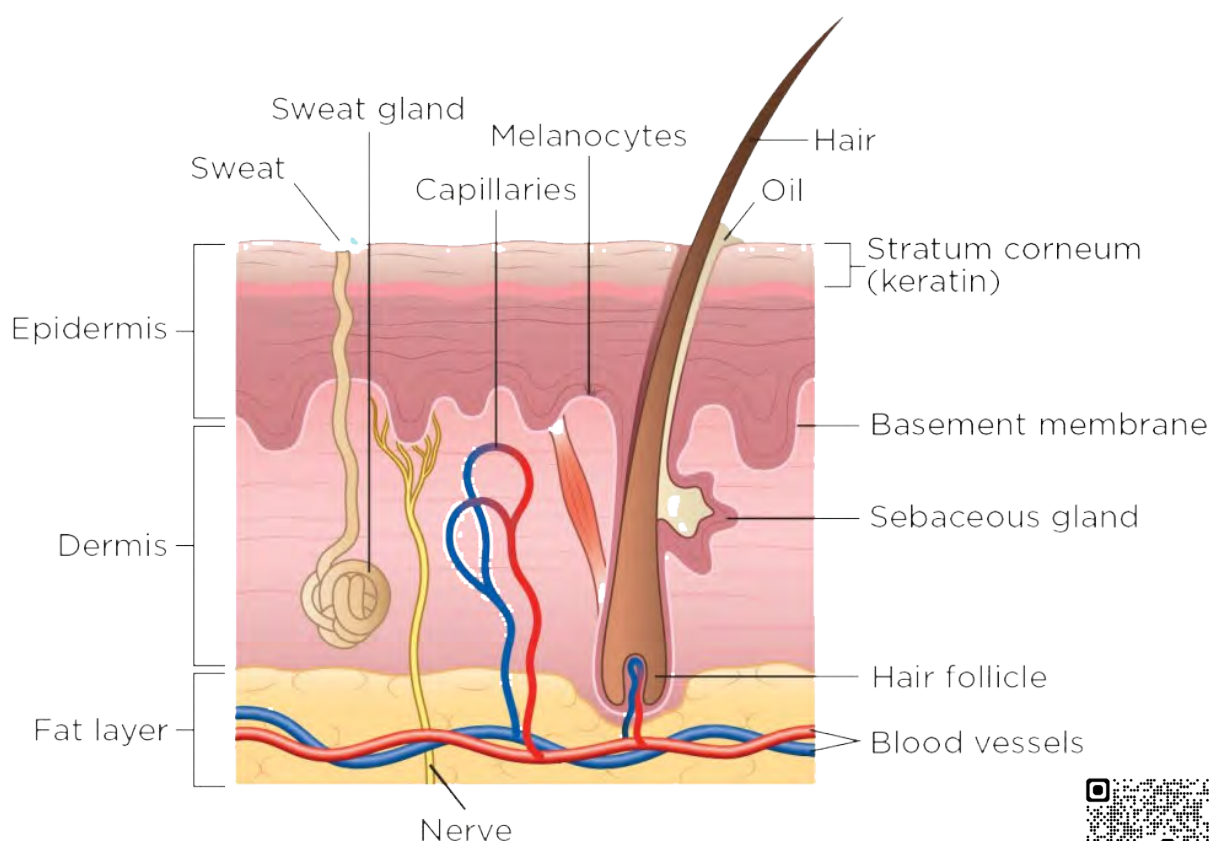

**Fig. 5. 2:** A labelled diagram of skin



**Table 5.2:** shows parts of the skin and their function:

Parts	Functions
Epidermis	<ol style="list-style-type: none"> <li>1. Creates a waterproof barrier that prevents excessive water loss from the body.</li> <li>2. Acts as a physical barrier that protects the body from bacteria, viruses, fungi, and other pathogens.</li> </ol>
Dermis	Provides strength and elasticity
Hypodermis	Helps to insulate the body, conserving heat and maintaining a stable internal temperature.
Hair follicle	Responsible for the production and growth of hair. An arrector pili muscle is attached to each hair follicle. This helps in the erection of hair when we experience cold or strong emotions.
Sweat gland	Releases sweat to cool down the body under hot environmental conditions. Sweat glands are found all over the skin and release sweat through specialised ducts. They help the body to excrete salts and minerals such as urea.
Sebaceous gland	Produce and secrete sebum, an oily substance that lubricates the skin and hair, preventing them from becoming dry.

Parts	Functions
Capillaries	Carry nutrients and Oxygen to skin cells and help regulate body temperature.
Nerve	Acts as sensory receptors for touch, pain, temperature, and pressure.
Stratum corneum	Provides a tough, protective layer that shields the underlying tissues from mechanical injury, chemical exposure, and pathogens.  Forms a water-resistant barrier that prevents excessive water loss from the body and protects against the entry of water.
Melanocytes	Produces melanin (skin pigment)
Fat tissue	Acts like a soft cushion, insulating our bodies and storing energy.

**Table 5.3: Functions of the Human Skin**

Barrier Function	The skin acts as a physical barrier protecting internal tissues from pathogens, chemicals, and physical injuries.
UV Protection	Melanin in the skin protects against harmful ultraviolet (UV) radiation from the sun.
Temperature Regulation	Through sweating and the dilation or constriction of blood vessels, the skin helps regulate body temperature. Sweating cools the body through evaporation, while blood vessel adjustments help conserve or release heat.  Water balance: The skin helps maintain the body's fluid balance by preventing excessive water loss.
Sensation	The skin contains a variety of nerve endings that detect touch, pressure, pain, and temperature, allowing for sensory perception and interaction with the environment.
Excretion	Through sweat, the skin helps remove waste products such as urea, salts, and other metabolic byproducts from the body.
Synthesis	Vitamin D Production: when exposed to UV radiation from the sun, the skin synthesizes vitamin D, which is essential for calcium absorption and bone health.
Immune defence	The skin is part of the body's immune system. It contains specialised cells like Langerhans cells that detect and fight off invading pathogens.

Storage	The skin acts as a reservoir for the synthesis and storage of lipids and water, contributing to the body's overall energy balance.
---------	--

## Processes involved in excretion by the skin

### 1. *Sweat Production*

Sweat glands in the dermis layer of the skin produce sweat, a watery fluid containing electrolytes, salts, and waste products.

There are two main types of sweat glands: eccrine glands, which are distributed throughout the body which produce a watery sweat for temperature regulation, and apocrine glands, found in areas like armpits and groin, which produce a thicker sweat with a stronger odour.

### 2. *Diffusion and Filtration*

Waste products like urea, uric acid, and ammonia (small amounts compared to kidneys) diffuse from the blood vessels surrounding the sweat glands into the sweat.

Sweat glands also filter out excess electrolytes and salts from the blood to maintain body fluid balance.

### 3. *Evaporation*

As sweat reaches the skin's surface, it evaporates into the surrounding air. This process removes heat from the body, helping to regulate body temperature, especially during exercise or hot weather.

## Learning Task

1. Identify excretory organs in the human body.
2. Explain the structure and the function of the skin.
3. Create a model of the skin.

## PEDAGOGICAL EXEMPLARS

### 1. Collaborative Learning

- a. Put learners in mixed groups to explore the concept of excretion using books/ internet.
  - i. Group learners create a concept map to illustrate key concepts such as metabolic waste, organs involved in excretion, and the importance of excretory processes for homeostasis.
  - ii. Encourage learners to present their work for the whole class discussion.

- b.** Use interactive anatomy models, diagrams, or virtual simulations to help learners identify major excretory organs in the human body, such as the kidneys, lungs, skin, liver and large intestine. Highlight the specific roles of each organ in waste removal and regulation of bodily fluids.
  - i.** Encourage learners in pairs to label structures, explain their functions to the class, and do presentations.
- c.** Provide scaffolding support for learners who may face challenges and assign roles such as group leader and secretary to group members. This approach promotes 21st-century skills and national core values while also considering cross-cutting issues such as Gender Equality and Social Inclusion (GESI) and Social and Emotional Learning (SEL)

## **2. Talk-for Learning**

- a.** With the help of visual aids, introduce learners to the structure and function of the various layers of cells in the skin. Ask learners to summarise the information into a table.
- b.** Using flashcards or a multiple-choice quiz, test learners on the definitions of the key terms that they have met in the study of the skin.

## **3. Project-based learning**

- a.** Let learners in mixed groups create a hands-on skin model using materials like clay, paper, and markers as project work.
  - i.** Facilitate discussion as they construct the model. Discuss the layers of the skin (epidermis, dermis, subcutaneous layer) and their functions (protection, sensation, temperature regulation). Let learners present their work for peer review.
- b.** Provide scaffolding support for learners who may face challenges and assign roles such as group leader and secretary to group members. This approach promotes 21st-century skills and national core values, while also considering cross-cutting issues such as Gender Equality and Social Inclusion (GESI) and Social and Emotional Learning (SEL)

## KEY ASSESSMENT

### Level 1

1. Multiple tests (5 questions covering lesson taught)

What is the role of the ureters in the excretory system?

- A) Filter waste from the blood
  - B) Regulate blood pressure
  - C) Store urine before it is excreted
  - D) Transport urine from the kidneys to the bladder
2. Identify and state the one function of excretory organs in the human body.

**Level 3:** Create a skin model using clay, paper, and markers as project work.

#### Hint



The recommended mode of assessment for week 5 is **multiple choice questions**. Use the level 1 question 1 as a sample question.

**WEEK 6**

**Learning Indicator:** Analyse the structure and function of the liver as an excretory organ in the human body.

## FOCAL AREA: UNDERSTANDING THE STRUCTURE AND FUNCTION OF HUMAN EXCRETORY ORGANS

### Structure and function of the liver as an excretory organ

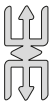

#### Note

Care should be taken here to ensure any learners with liver diseases are notified of this topic in advance, as it may cause distress.

The liver is reddish-brown and shaped approximately like a cone or a wedge. The small end is above the spleen and stomach, and the large end is above the small intestine. The entire organ is located below the lungs in the right upper abdomen.

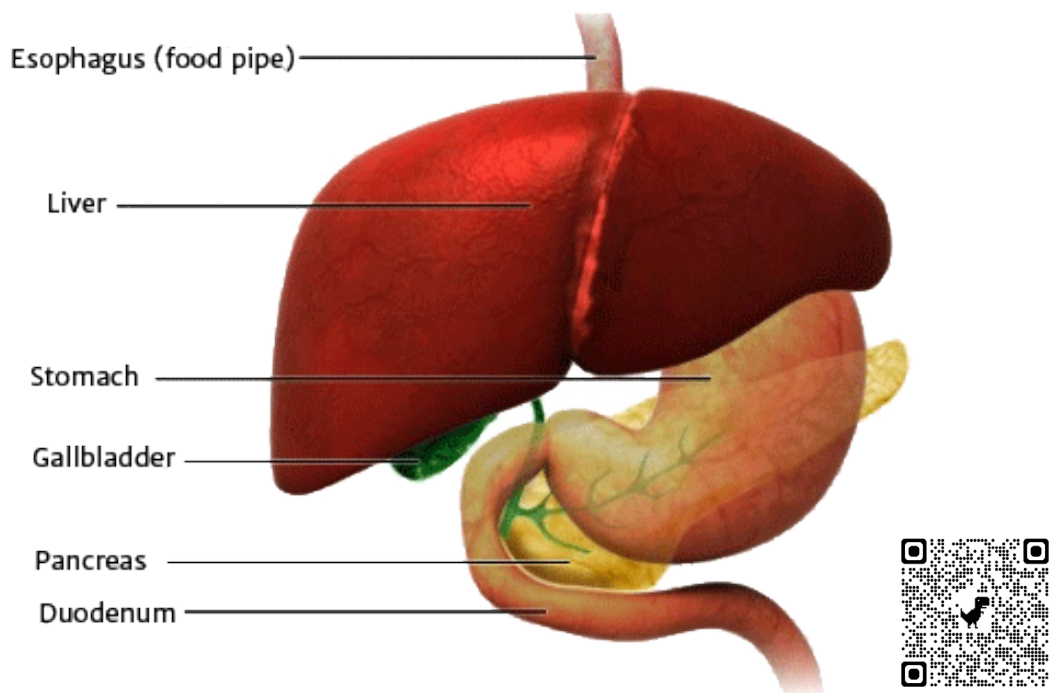
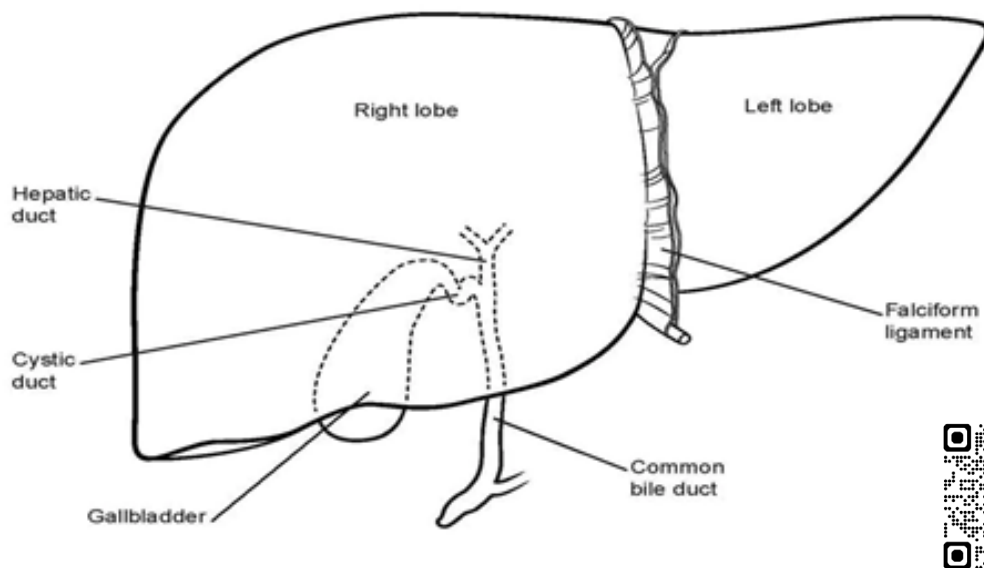
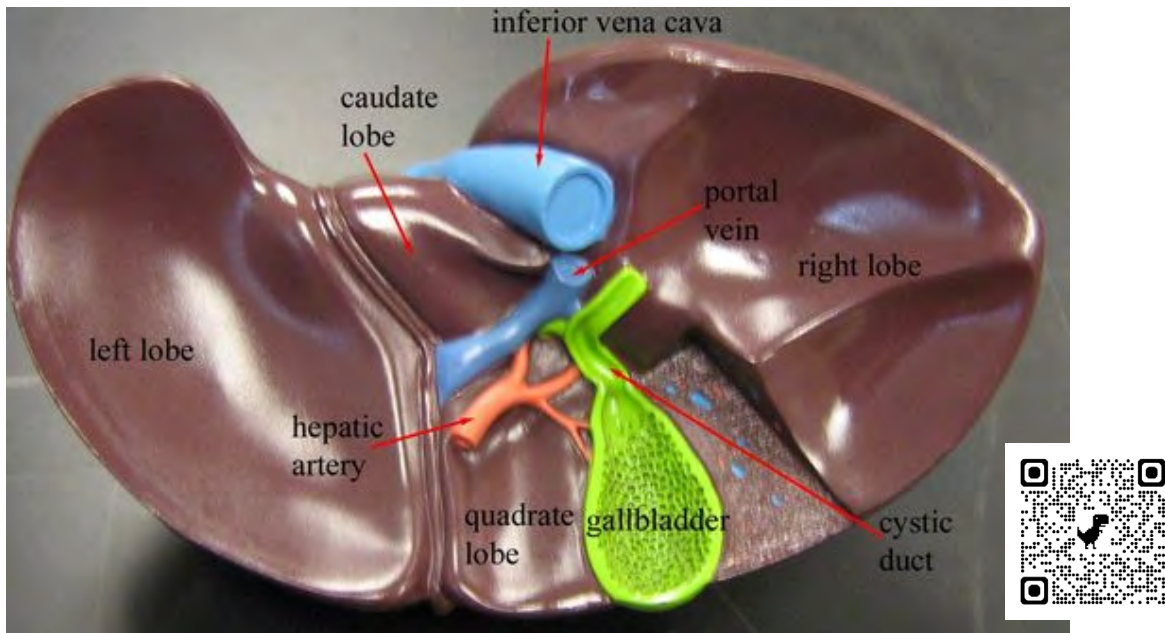

**Fig. 5.3:** A well labelled diagram of the liver

### Structure of the Liver

The liver consists of four lobes: the (larger) right and left lobes and the smaller caudate quadrate lobes. The left and right lobes are divided by the falciform (“sickle-shaped” in Latin) ligament, which connects the liver to the abdominal wall.

The liver's lobes can be further divided into eight segments, consisting of thousands of lobules (small lobes). Each of these lobules has a duct flowing toward the common hepatic duct, which drains bile from the liver.



**Fig. 5.4:** A well labelled diagram of liver

### Segments of the Liver (Hepatic segments)

Each sector is subsequently divided into two, producing eight hepatic segments. If the patient is supine (laying on their back facing up), and the liver is reflected along its inferior border towards the diaphragm, the segments would be numbered anti-clockwise around the porta hepatis.

Segment I – the caudate lobe – is the posterosuperior part of the left medial sector.

Segments II to VIII make up the left and right lobes as explained below.

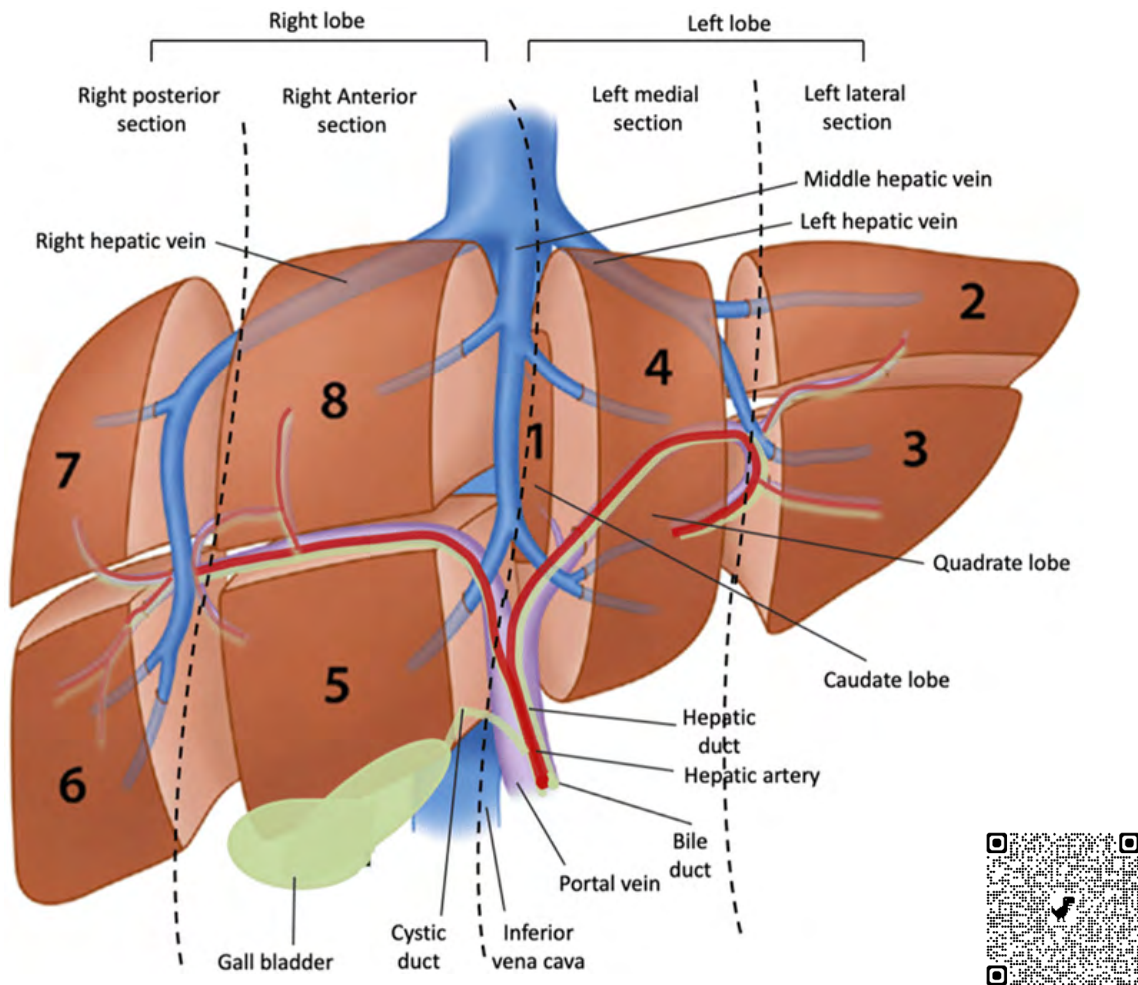

**Fig. 5.5:** A Diagram of segments of the liver

## The left lobe of the liver

The left lobe of the liver is located on the left side of the body (remember this will be the patient's left), just under the diaphragm. It is generally smaller and more wedge-shaped than the right lobe.

## The right lobe of the liver

The right lobe is the larger of the two primary lobes of the liver. It is located predominantly in the right hypochondrium and extends into the epigastrium.

It is significantly larger than the left lobe. Separated from the left lobe by the falciform ligament on its superior surface and from the caudate lobe by the right sagittal fissure.

## Functions of the liver

The liver regulates most chemical levels in the blood and excretes a product called bile. This helps carry away waste products from the liver. All the blood leaving the stomach and intestines passes through the liver. The liver processes this blood and breaks down, balances, and creates the nutrients. It also metabolises drugs into forms that are either easier to use for the rest of the body or nontoxic.

1. Production of bile, which helps carry away waste and break down fats in the small intestine during digestion.
2. Production of certain proteins for blood plasma.
3. Production of cholesterol and special proteins to help carry fats through the body.
4. Convert excess glucose into glycogen for storage (glycogen can later be converted back to glucose for energy), balance, and make glucose as needed.
5. Regulation of blood levels of amino acids, which form the building blocks of proteins.
6. Processing of haemoglobin for the use of its iron content (the liver stores iron).
7. Conversion of poisonous ammonia to urea (urea is an end product of protein metabolism and is excreted in the urine).
8. Clearing the blood of drugs and other poisonous substances.
9. Regulating blood clotting.
10. Resisting infections by making immune factors and removing bacteria from the bloodstream.
11. Clearance of bilirubin, also from red blood cells. If there is an accumulation of bilirubin, the skin and eyes turn yellow.

### Processes involved in excretion by the liver

The liver plays a vital role in excretion by eliminating various waste products and toxins from the body. Here are the key processes involved in this function:

*Breakdown of Ammonia:* Ammonia is a toxic byproduct of protein metabolism that occurs throughout the body, especially in the muscles.

Process: The liver utilizes the urea cycle to convert ammonia into a less toxic substance called urea. Urea is much easier for the kidneys to eliminate through urine.

*Bilirubin Elimination:* Bilirubin is a yellowish pigment produced during the normal breakdown of red blood cells.

Process: The liver captures bilirubin and conjugates it with other molecules (making it water-soluble) and then secretes it into bile. Bile is a digestive fluid that eventually travels to the intestines and is eliminated in faeces.

*Detoxification:* The liver acts as a detoxifying organ, processing various substances like drugs, alcohol, and environmental toxins.

Process: The liver enzymes break down or modify these substances into less harmful forms that can be excreted through bile or urine.

*Elimination of Excess Hormones and Other Molecules:* The liver can regulate the levels of various hormones, such as sex hormones and thyroid hormones, by breaking them

down or excreting them in bile. Additionally, it removes excess molecules like bilirubin and cholesterol from the bloodstream.

*Contribution to Blood Purification:* By performing these excretion processes, the liver plays a crucial role in filtering and purifying the blood. It removes waste products, toxins, and excess substances, maintaining a healthy internal environment for the body to function properly.

## EXPERIMENT 6.1 – How to create a liver model

**Apparatus:** Large styrofoam block, smaller styrofoam pieces (for details), craft knife or hot wire styrofoam cutter, sandpaper (fine grit), acrylic paints and brushes, markers or pens, toothpicks or small sticks (for labelling), labels or small flags, glue (styrofoam-safe), anatomy reference images or diagrams

### Procedure

Collect all necessary materials, including the styrofoam block, craft knife, paints, and reference images.

Using a marker, sketch the outline of the liver on the large styrofoam block. The liver has a roughly triangular shape with a curved surface.

1. Carefully cut out the liver shape from the styrofoam block using a craft knife or hot-wire styrofoam cutter. Ensure that you follow the outline accurately.
2. Smooth the Edges.
3. Use fine-grit sandpaper to smooth the edges and surface of the styrofoam liver shape, creating a more realistic appearance.
4. Define the Lobes.
5. Sketch the division between the right and left lobes on the styrofoam model. The right lobe should be larger than the left lobe.
6. Use the craft knife to make shallow cuts along the division lines to define the lobes.
7. Anatomical Landmarks.
8. Create additional anatomical landmarks such as the falciform ligament, caudate lobe, and quadrate lobe using smaller pieces of styrofoam. Glue these pieces in place.
9. Sculpt the caudate lobe on the posterior side and the quadrate lobe adjacent to where the gallbladder would be.

**Segment the Lobes**

1. Draw and lightly carve the segments of the right and left lobes:
2. Right lobe: Segments V, VI, VII, VIII
3. Left lobe: Segments II, III, IVa, IVb
4. Use the craft knife to make shallow indentations to separate the segments.

**Paint the Model**

1. Paint the entire liver model using acrylic paints. Use different shades to highlight the right and left lobes and their respective segments.
2. Paint the additional anatomical landmarks in different colours for distinction.

**Detail the Blood Vessels and Ducts**

1. Paint the major blood vessels (e.g., hepatic artery, portal vein, hepatic veins) and bile ducts on the liver model using fine brushes.
2. Use reference images to place these structures accurately on the model.

**Label the Parts**

1. Create small labels or flags using paper, toothpicks, or small sticks.
2. Insert the labelled toothpicks into the corresponding parts of the styrofoam liver model, marking each lobe, segment, and major structure.

**Attach Additional Details (Optional)**

If desired, use small pieces of styrofoam to add more details, such as the gallbladder or inferior vena cava, and paint them accordingly.

**Review**

1. Compare the model to anatomical references and make any necessary adjustments for accuracy.
2. Ensure all parts are securely attached and clearly labelled.

**Present the Model**

1. Use the model to explain liver anatomy, pointing out and describing each part and its function.
2. Encourage interactive discussion and questions to reinforce learning.

## EXPERIMENT 6.2 - Experiment on dissection of the liver to identify the parts

**Apparatus:** Preserved sheep or cow liver (not recommended for home use due to biohazard risks) (take care here to know if any learners are unable to take part/observe due to religious reasons), dissection tray, scalpel, blunt dissection probe, forceps, scissors, gloves, eye protection, biohazard waste disposal container

### Procedure

1. Wear gloves, eye protection, and a lab coat. Ensure a clean and well-ventilated work area.
2. Place the liver on the dissection tray. Observe its overall shape, size, and surface features, such as lobes, gall bladder (if attached), and major blood vessels.
3. Using a scalpel, carefully make a shallow incision along the midline of the liver capsule, the thin outer membrane.
4. Gently peel back the capsule to expose the underlying liver tissue. Identify the two major lobes: right and left.
5. Locate the hepatic portal vein, hepatic artery, and hepatic vein on the liver's visceral surface (underside). Follow their paths into the liver tissue.
6. If present, identify the bile duct and trace its course from the gall bladder (if attached) to the liver hilum (where blood vessels and bile ducts enter/exit).

### Learning Task

1. Identify and label parts of the liver.
2. Describe the functions of the liver.
3. Create a model of the liver.
4. Dissect a sheep or cow's liver to identify its key structures.

## PEDAGOGICAL EXEMPLARS

### 1. Teacher-led Learning

- a. Guide learners through describing the structure of the liver using diagrams, illustrations, and animations. Highlight key anatomical features such as the hepatic lobules, portal system, and bile ducts.
  - i. Learners should be encouraged to generate their own version of each key term's "function" after listening and reading the required materials rather than having it given to them. This can be scaffolded (for lower-ability

learners) using pre-made definitions that need to be matched instead of generated.

- b.** Encourage learners to ask questions and facilitate a dialogue about the liver's functions beyond digestion, emphasising its crucial role in detoxification and waste elimination.
- c.** Provide scaffolding support for learners who may face challenges and assign roles such as group leader and secretary to group members. This approach promotes 21st-century skills and national core values while also considering cross-cutting issues such as Gender Equality and Social Inclusion (GESI) and Social and Emotional Learning (SEL)

## **2. Experiential learning**

- a.** Put learners in mixed groups and guide them on hands-on activities on dissection of the liver.
  - i.** Engage learners in an interactive discussion as they perform their activities to highlight key anatomical features such as the hepatic lobules, hepatic portal system, and bile ducts. Encourage learners to reflect and peer review their works.
- b.** Provide scaffolding support for learners who may face challenges and assign roles such as group leader and secretary to group members. This approach promotes 21st-century skills and national core values while also considering cross-cutting issues such as Gender Equality and Social Inclusion (GESI) and Social and Emotional Learning (SEL)

## **3. Project-based learning**

- a.** Put learners into mixed-ability groups and guide them to create models, posters, or multimedia projects explaining the structure of the liver.
  - i.** Organise a gallery walk where groups showcase their projects and engage in discussions with classmates and teachers.
- b.** Provide scaffolding support for learners who may face challenges and assign roles such as group leader and secretary to group members. This approach promotes 21st-century skills and national core values while also considering cross-cutting issues such as Gender Equality and Social Inclusion (GESI) and Social and Emotional Learning (SEL)

## KEY ASSESSMENT

**Level 1:** Identify at least four parts of the liver.

**Level 2:** Describe the four lobes of the liver

**Level 3:** Using styrofoam, paper, clay, etc., create a model of the liver.

### Hint



The recommended mode of assessment for week 6 is **Mid-semester examination**. Refer to the Appendix D for more sample task and the Table of Specification

**WEEK 7**

**Learning indicator:** Describe the processes for the removal of waste from the human body.

## FOCAL AREA: PROCESSES OF REMOVING WASTE FROM THE HUMAN BODY VIA THE KIDNEYS

### Structure and function of the kidney

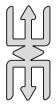

#### Note

Care should be taken here to ensure any learners with kidney diseases are notified of this topic in advance as it may cause distress

The kidneys are a pair of bean-shaped organs that are found high in the back of the abdominal cavity, just below the rib cage; one on either side of the spine. The right kidney is slightly lower than the left because of the position of the liver.

The adrenal glands sit on top of each kidney and are also called the suprarenal glands. Kidneys filter and purify blood. All the blood in the human body is filtered many times a day by the kidneys; these organs use up almost 25 percent of the Oxygen absorbed through the lungs to perform this function. Oxygen allows the kidney cells to efficiently manufacture chemical energy in the form of ATP (adenosine triphosphate) through aerobic respiration. The filtrate coming out of the kidneys is called urine.

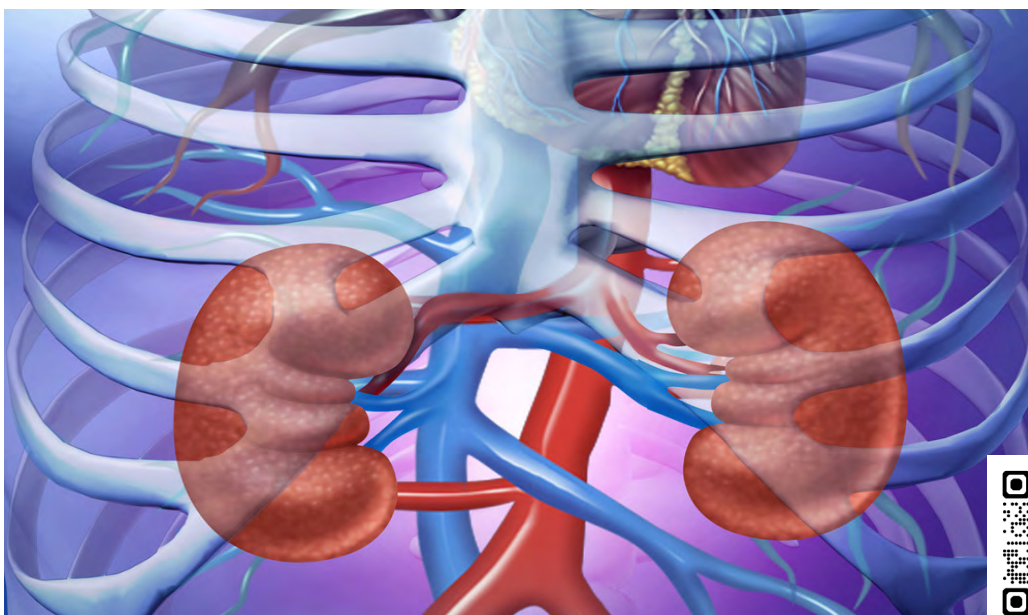

**Fig. 7. 1:** A diagram showing the position of the kidney in human

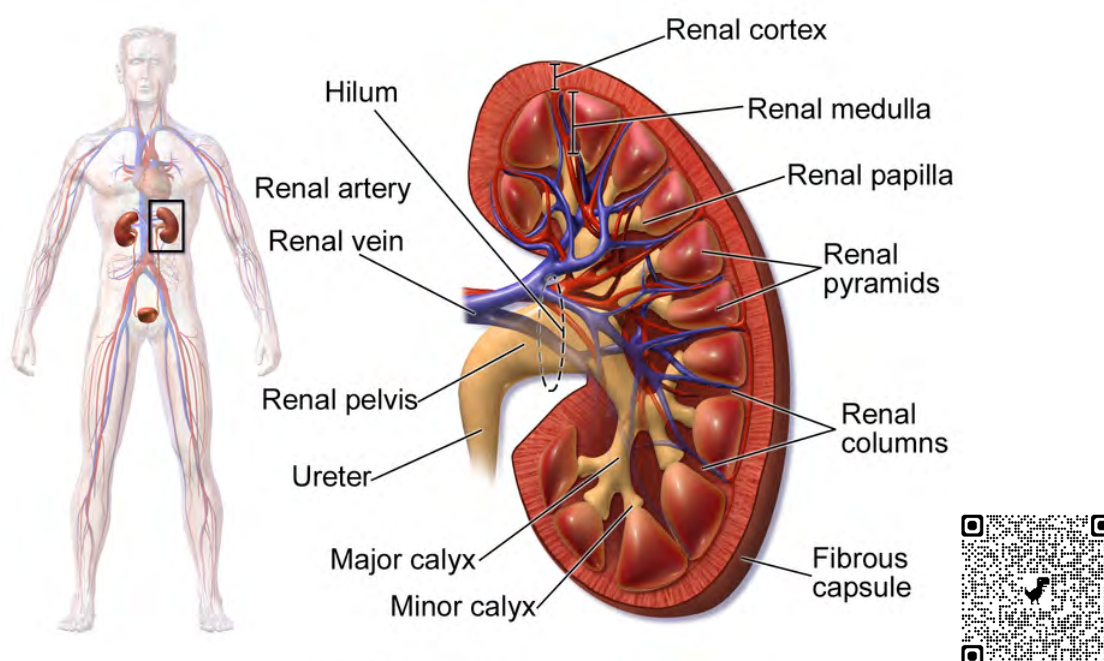

**Fig. 7. 2:** A well-labelled diagram showing the parts of the human kidney

**Table 7.1:** Parts and function of the kidney

Part	Function
Renal cortex	Site for filtration. It contains the nephrons.
Renal pelvis	Collects urine from the major calyces and channels it into the ureter for elimination from the body.
Renal vein	Carries deoxygenated blood from the kidney and returns it to the systemic circulation via the inferior vena cava.
Renal artery	It supplies oxygenated blood to the kidneys for filtration.
Renal pyramid	They are crucial in transporting urine from the cortex to the renal pelvis.
Renal medulla	Contains the loops of Henle and collecting ducts, which are essential for concentrating urine and maintaining water balance.
Ureter	Sends urine from the kidney to the urinary bladder
Capsule	It is a tough, fibrous outer layer that protects the kidney from physical damage and maintains its shape.
Minor calyx	Collect urine from the papillae of the renal pyramids.
Major calyx	They channel urine from the renal pyramids into the renal pelvis.
Hilum	Provides a pathway for blood vessels, nerves, and the passage of urine.
Renal column	They contain blood vessels and urinary tubules that supply and drain the nephrons.

## Structure of the Nephron

The nephron is the functional unit of the kidney. Each kidney is made up of over one million nephrons that dot the renal cortex. A nephron consists of three parts: a renal corpuscle, a renal tubule, and the associated capillary network, which originates from the cortical radiate arteries.

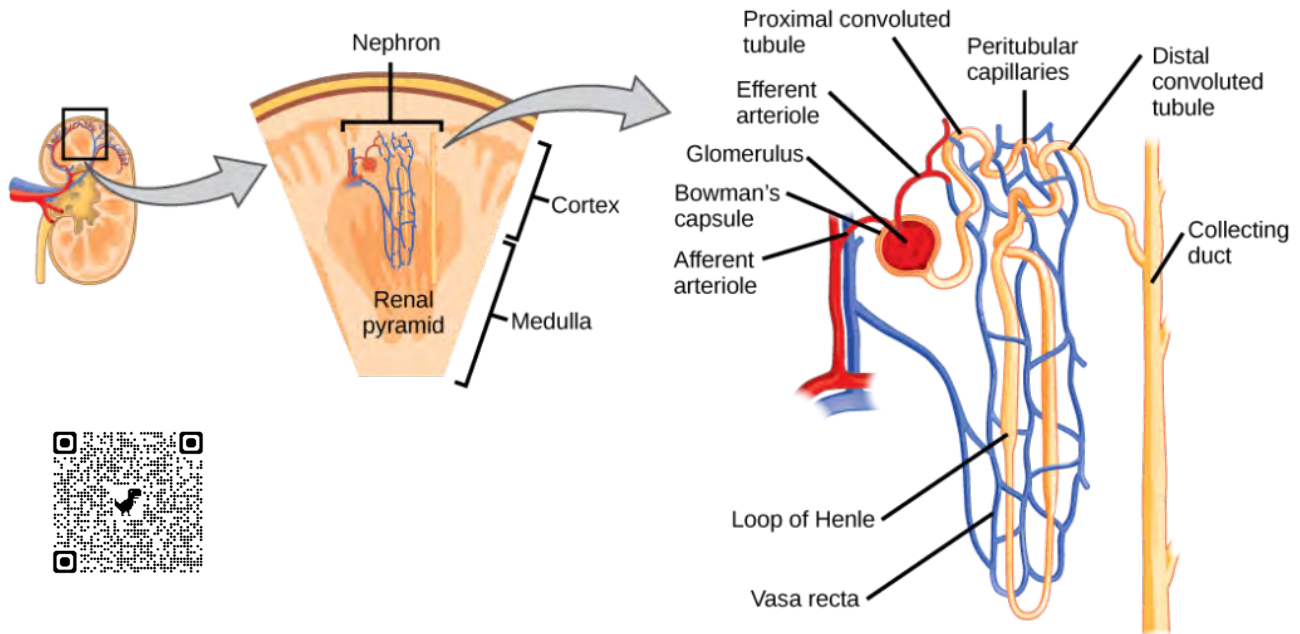

**Fig.7. 3:** A well-labelled diagram showing the parts of the human nephron

## Functions of parts of the Nephron

**Table 7.2:** parts of nephron and their function:

Parts	Function
Renal Corpuscle (Glomerulus + Bowman's Capsule)	The renal corpuscle initiates the process of urine formation by filtering blood plasma. The glomerulus, a network of capillaries, filters water, ions, glucose, and waste products from the blood into Bowman's Capsule. This filtrate is the initial step in forming urine
Proximal Convoluted Tubule (PCT)	Located immediately after Bowman's Capsule in the renal cortex, the PCT reabsorbs most of the filtered water and solutes (such as sodium, glucose, amino acids, and bicarbonate) back into the bloodstream. This reabsorption helps maintain body fluid balance and prevents the loss of valuable substances.

Parts	Function
Loop of Henle	The loop of Henle, extending into the renal medulla, creates an osmotic gradient that allows for the concentration of urine. It consists of a descending limb (permeable to water) and an ascending limb (impermeable to water but actively transports ions like sodium and chloride out of the tubule). This process enables the kidney to conserve water and concentrate urine.
Distal Convolved Tubule (DCT)	The DCT, located in the renal cortex after the loop of Henle, regulates the concentration of urine by further reabsorbing sodium ions and water from the tubular fluid into the bloodstream. It also secretes potassium ions and hydrogen ions into the tubule, contributing to acid-base balance and electrolyte regulation
Collecting Duct	Collecting ducts receive urine from multiple nephrons and transport it through the renal medulla to the renal pelvis. They play a crucial role in determining the final concentration or dilution of urine based on the body's hydration status. The collecting ducts reabsorb water under the influence of antidiuretic hormone (ADH), concentrating urine when water needs to be conserved.
Peritubular Capillaries	Peritubular capillaries surround the proximal and distal convoluted tubules as well as the loop of Henle. They reabsorb substances (e.g., water, ions, glucose) from the renal tubules back into the bloodstream and participate in the secretion of waste products and drugs into the tubules for excretion.

## Urine formation

Urine formation involves three processes. These are filtration, re-absorption and secretion.

### *Filtration*

This process begins in the renal corpuscle, which consists of the glomerulus (a network of capillaries) and Bowman's capsule (a hollow, cup-like structure). Blood enters the glomerulus via the afferent arteriole and exits via the efferent arteriole. The high pressure in the glomerular capillaries forces water, ions, small molecules (e.g., glucose, amino acids), and waste products (e.g., urea, creatinine) out of the blood and into Bowman's Capsule. This initial filtrate is called the glomerular filtrate.

### *Re-absorption*

The glomerulus filters water and small solutes out of the bloodstream. The resulting filtrate contains waste, but also other substances the body needs: essential ions, glucose, amino acids, and smaller proteins. When the filtrate exits the glomerulus, it flows into a duct in the nephron called the renal tubule. As it moves, the needed substances and some waters are re-absorbed through the tube wall into adjacent capillaries. This re-absorption of vital nutrients from the filtrate is the second step in urine formation.

### *Secretion*

The filtrate absorbed in the glomerulus flows through the renal tubule, where nutrients and water are re-absorbed into capillaries. At the same time, waste ions and Hydrogen ions pass from the capillaries into the renal tubule. This process is called secretion. The secreted ions combine with the remaining filtrate and become urine. The urine flows out of the nephron tubule into a collecting duct. It passes out of the kidney through the renal pelvis, into the ureter, and down to the bladder.

## EXPERIMENT 7.1 – Experiment on Renal Filtration

This hands-on activity simulates the process of renal filtration in the kidneys using common household items.

**Aim:** To demonstrate how kidneys filter waste from the blood.

**Apparatus:** Plastic bottles, gravel, sand, activated charcoal, coffee filters, water, food colouring.

### **Procedure**

1. Cut the bottom off two plastic bottles and invert them to use as funnels.
2. Place a coffee filter at the bottom of each bottle.
3. Fill the first bottle with layers of gravel, sand, and activated charcoal to simulate the filtration layers of the kidney.
4. Mix water with food colouring to represent blood with waste.
5. Pour the coloured water through the filter layers and observe how it becomes clearer, simulating how kidneys filter blood.

### **Observation**

Watch as the water trickles through the coffee filter. The coffee filter acts as a barrier, like the glomerulus in the kidney.

## EXPERIMENT 7.2 - Experiment simulating blood filtration

**Aim:** To simulate the separation of components in blood.

**Apparatus:** Red food colouring, oil, water, funnel, filter paper.

### Procedure

1. Mix red food colouring with water to represent blood.
2. Add oil to the mixture to represent fat and other substances.
3. Pour the mixture through a funnel lined with filter paper.
4. Observe how the “blood” is separated into different components, like the filtration process in kidneys.

### Learning Tasks

1. Identify the parts of the kidney
2. Describe the structure and function of the kidney.
3. Perform experiments to model blood filtration.

## PEDAGOGICAL EXEMPLARS

### 1. Talk-for-learning

- a. Introduce learners to the main structure and functions of the kidney, using visual aids and interactive models to aid your descriptions.
- b. Put learners in mixed groups with guided enquiry questions or a table to fill in about the structure and function of the kidney; learners should answer these with the aid of research resources, and this will form their notes for the topic.
- c. Provide learners with resources such as diagrams, videos, and articles to explore in groups. Encourage learners to investigate topics such as renal filtration, reabsorption, and secretion and present their findings to the class. Facilitate discussions to deepen understanding and clarify concepts.
- d. Provide scaffolding support for learners who may face challenges and assign roles such as group leader and secretary to group members. This approach promotes 21st-century skills and national core values while also considering cross-cutting issues such as Gender Equality and Social Inclusion (GESI) and Social and Emotional Learning (SEL)

### 2. Project-based learning

- a. Let learners perform experiments (detailed above) to model the function of the kidneys in the filtration of blood. Ask them to summarise how the model

demonstrates the function, but also to highlight the limitations of the model and the details that it does not show.

- b. Provide scaffolding support for learners who may face challenges and assign roles such as group leader and secretary to group members. This approach promotes 21st-century skills and national core values, while also considering cross-cutting issues such as Gender Equality and Social Inclusion (GESI) and Social and Emotional Learning (SEL)

## KEY ASSESSMENT

**Level 1:** Identify five parts of the kidney.

**Level 2:** Describe the structure of the kidney.

**Level 3:** Critically analyse one experimental model of the function of the kidneys, commenting on processes that are accurately demonstrated and on the limitations of the model.

### Hint



The recommended mode of assessment for week 7 is **questioning**. Use the level 1 question as a sample question.

**WEEK 8**

**Learning indicator:** Describe the processes for the removal of waste from the human body.

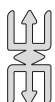
**FOCAL AREA: PROCESSES OF REMOVING WASTE FROM THE HUMAN BODY****Processes involved in excretion of waste by the lungs****Note**

Care should be taken here to ensure any learners with lung diseases are notified of this topic in advance as it may cause distress

The lungs are a crucial part of the human body's excretory system. They are responsible for the removal of waste products generated during the process of cellular respiration. This process involves the breakdown of glucose in the presence of oxygen to produce energy, carbon dioxide, and water. The energy produced is used by the body for various functions, while the carbon dioxide and water are waste products that need to be removed.

The lungs play a vital role in this removal. When we inhale, oxygen-rich air enters our lungs. This oxygen is then absorbed by the blood in the capillaries surrounding the alveoli, tiny air sacs in the lungs. At the same time, the waste carbon dioxide in the blood is released into the alveoli. This exchange of gases occurs due to diffusion, where gases move from an area of high concentration to an area of low concentration.

When we exhale, the carbon dioxide that has been collected in the alveoli is expelled from the body. This is how the lungs excrete the waste product carbon dioxide. Additionally, a small amount of water vapour is also expelled during exhalation. This water vapour is a by-product of the body's metabolic processes, and its removal helps to maintain the body's water balance.

In summary, the lungs excrete waste products through the process of respiration, where carbon dioxide and water vapour are expelled from the body during exhalation. This process is essential for maintaining the body's pH balance and preventing the build-up of harmful waste products.

## Processes involved in excretion by the large intestine

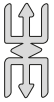

### Note

Care should be taken here to ensure any learners with lung diseases are notified of this topic in advance as it may cause distress

The large intestine plays a crucial role in waste excretion by processing leftover material from the small intestine and eliminating it from the body as faeces. Here's a breakdown of the key processes involved:

1. **Receiving undigested material:** After digestion in the small intestine, the remaining chyme (partially digested food mixed with digestive juices) enters the large intestine through the ileocecal valve.

This chyme still contains undigested materials like cellulose (fibre), indigestible parts of food, dead bacteria from the small intestine, and some water.

2. **Water absorption:** The large intestine's primary function is water absorption.

Large intestine walls are lined with cells that actively absorb water from the remaining chyme.

This water absorption concentrates the remaining material, forming a thicker consistency.

3. **Electrolyte balance:** The large intestine also absorbs electrolytes (salts and minerals) from the chyme.

This helps maintain the body's electrolyte balance, which is crucial for various functions.

4. **Stool formation:** As water is absorbed, and some fermentation occurs by gut bacteria, the remaining material thickens and solidifies further, forming a stool (faeces).

Stools typically consist of undigested food matter (cellulose), dead intestinal cells, mucus and bacteria.

5. **Mass movement and storage:** The large intestine has muscular contractions that move the stool slowly towards the rectum.

These contractions are called mass movements.

The rectum acts as a temporary storage area for stools until elimination.

6. **Elimination (defecation):** When stools reach the rectum, they stretch the rectal wall, triggering the urge to defecate.

The relaxation of the anal sphincter muscles and voluntary contraction of abdominal muscles allow for the expulsion of the stool through the anus.

## Learning tasks

1. Describe the processes involved in the excretion of waste by the lungs.
2. Describe the processes involved in excretion by the large intestine
3. Perform a hands-on activity to create a respiratory system model.

## PEDAGOGICAL EXEMPLARS

### 1. Talk-for-learning

- a. Provide learners with resources such as videos, articles, or online modules explaining waste excretion by the lungs and the large intestine. Allow learners to discuss key concepts like gaseous exchange in the lungs.
- b. Provide learners with resources such as videos, articles, or online modules explaining waste excretion by the large intestine.
- c. Task learners in their groups to explore common intestinal and lung diseases and how they affect the function of the lungs or intestines.
- d. Ask learners to present their findings through posters, presentations, or written reports. Host a mini-exhibition or presentation session where groups showcase their projects and engage in peer discussions and feedback.
- e. Provide scaffolding for less able learners to ensure that they limit their research to information of an appropriate level; for example, give them a list of key questions or points to address in their presentations, or a blank flow-chart for them to fill in demonstrating each process. This approach promotes 21st-century skills and national core values while also considering cross-cutting issues such as Gender Equality and Social Inclusion (GESI) and Social and Emotional Learning (SEL)

### 2. Activity/Project-based learning

- a. In mixed-ability groups, challenge learners to produce their own model of the digestive system. They can use online resources to research how to create these models. Learners should produce a video demonstrating the use of their model and should provide a voice-over or accompanying notes to explain the processes. This should be submitted to the teacher or peer-reviewed.
- b. Provide scaffolding support for learners who may face challenges and assign roles such as group leader and secretary to group members. This approach promotes 21st-century skills and national core values while also considering cross-cutting issues such as Gender Equality and Social Inclusion (GESI) and Social and Emotional Learning (SEL)

## KEY ASSESSMENT

**Level 1:** Identify at least three processes involved in the excretion of waste by the large intestine.

**Level 2:** Describe the processes involved in excretion by the large intestine.

**Level 3:** Analyse the differences in the processes involved in the lungs and large intestine excretion and present your findings.

### Hint



The recommended mode of assessment for week 8 is **presentation**. Use the level 3 question as a sample question.

**WEEK 9**

**Learning indicator:** Describe the processes for the removal of waste from the human body.

## FOCAL AREA: DISORDERS OF THE HUMAN EXCRETORY SYSTEM

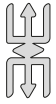

### Note

Care should be taken here to ensure any learners [or close relatives of learners] with specific disorders are not upset by the delivery of this section.

### Kidney disorders

Kidney disorders encompass a range of conditions that affect the function and health of the kidneys. These disorders can lead to impaired blood filtering, fluid balance, and waste elimination.

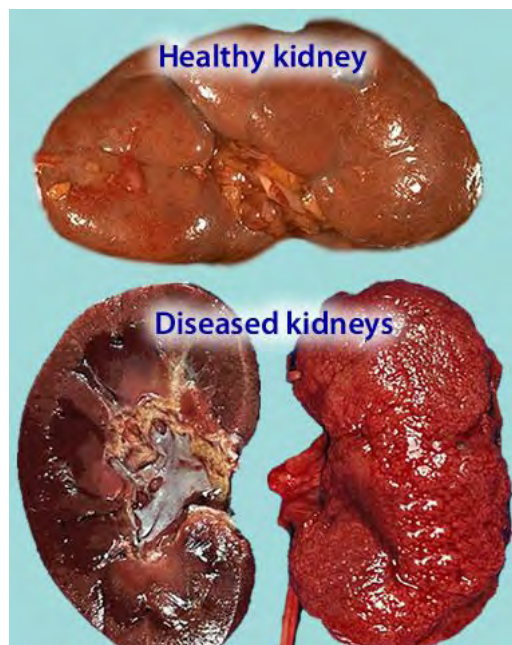

**Fig. 9.1:** Diagram showing a healthy and unhealthy kidney

## Common kidney disorders

	Description	Causes	Symptoms	Treatment
<b>Chronic Kidney Disease (CKD)</b>	A gradual loss of kidney function over time.	High blood pressure and diabetes are the leading causes of CKD. Other factors include autoimmune diseases, prolonged use of certain medications, and genetic conditions.	Early CKD often has no symptoms. In later stages, symptoms may include fatigue, frequent urination (especially at night), blood in the urine, high blood pressure, puffiness around the eyes, and loss of appetite.	Treatment focuses on managing the underlying cause and slowing disease progression. This may involve medications to control blood pressure and sugar, dietary changes, and lifestyle modifications. In severe cases, dialysis (a process that removes waste products from the blood) or a kidney transplant may be necessary.
<b>Kidney Stones</b>	Solid formations composed of minerals and salts that develop in the kidneys.	Mineral build-up in the urine can form hard crystals that become kidney stones. Dehydration, diet (high in sodium and oxalates), certain medications, and some medical conditions can increase the risk.	Severe lower back or abdomen pain that may radiate to the groin. Other symptoms include blood in the urine, nausea, and vomiting.	Treatment depends on the size and location of the stone. Small stones may pass on their own with increased fluid intake. Pain medication can help manage discomfort. Larger stones may require procedures like shock wave lithotripsy (using sound waves to break up the stones) or surgery.

	Description	Causes	Symptoms	Treatment
<b>Glomerulonephritis (GN)</b>	Inflammation of the glomeruli, the tiny filters in the kidneys	GN is an inflammation of the glomeruli, made up of tiny kidney filters. Infections, autoimmune diseases, or certain medications can cause it.	Symptoms vary depending on the severity and type of GN. They may include blood in the urine, high blood pressure, swelling (oedema), and protein.	Treatment depends on the cause. Medications may suppress the immune system, reduce inflammation, or control blood pressure. In severe cases, dialysis or a kidney transplant may be needed.
<b>Acute Kidney Injury (AKI)</b>	A rapid decline in kidney function.	Extreme dehydration, haemorrhage, severe infections, trauma, specific medications, and urinary tract obstructions.	Decreased urine production, leg and ankle swelling, difficulty breathing, mental confusion, and chest discomfort.	<p>Regulate fluid intake to ensure proper hydration or limiting fluids if necessary.</p> <ul style="list-style-type: none"> <li>• Use diuretics to promote urine production and drugs to regulate potassium levels in the blood.</li> <li>• Treat infections and stop the intake of harmful medications.</li> <li>• Temporary dialysis may be required to eliminate toxins from the bloodstream.</li> </ul>

	Description	Causes	Symptoms	Treatment
<b>Polycystic Kidney Disease (PKD)</b>	A genetic disorder characterized by the growth of numerous cysts in the kidneys.	Genetic mutations.	High blood pressure, back or side pain, blood in urine, and frequent kidney infection.	<ul style="list-style-type: none"> <li>• Surgery to remove cysts, drinking plenty of water to prevent kidney stones.</li> <li>• Treat kidney infections, dialysis or kidney transplant.</li> </ul>
<b>Nephrotic Syndrome</b>	A disorder causing the kidneys to excrete too much protein in the urine.	Kidney diseases like minimal change disease, focal segmental glomerulosclerosis, and membranous nephropathy.	Severe swelling, particularly around the eyes and in the ankles and feet, foamy urine, and weight gain due to fluid retention.	<ul style="list-style-type: none"> <li>• Medications: Corticosteroids, immunosuppressive drugs, blood pressure medications, diuretics, anticoagulants.</li> <li>• Dietary Changes: Low-sodium diet, low-protein diet in some cases.</li> </ul>

## Skin disorders

A skin disorder is any condition affecting the skin's appearance, texture, or function. These disorders can vary widely in their causes, symptoms, and severity.

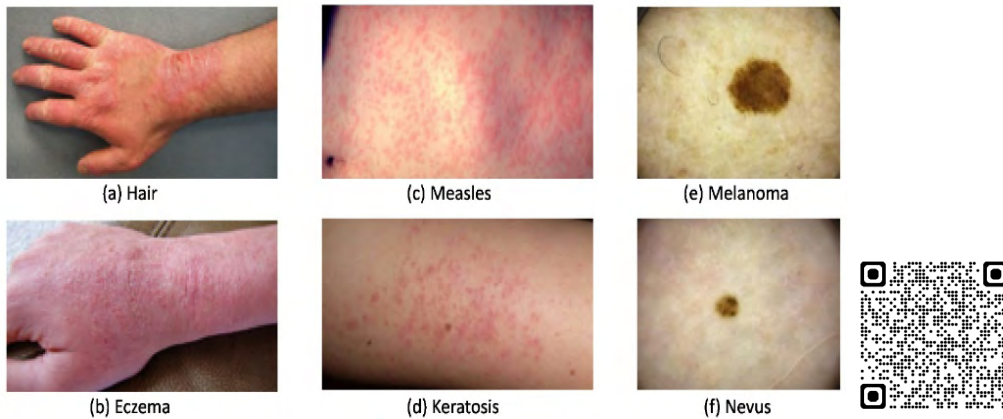

**Fig.9. 3:** Diagram showing various skin disease

## Common skin disorders

	Description	Causes	Symptoms	Treatment
<b>Acne</b>	A condition characterized by pimples, blackheads, and cysts due to clogged pores and inflammation.	Androgens (hormones) stimulate oil production in the sebaceous glands. When this oil clogs pores and dead skin cells, bacteria can grow, leading to breakouts. Stress, diet, and certain medications can also contribute.	Acne's characteristic symptoms include whiteheads, blackheads, pimples, and deeper, painful cysts. It can appear on the face, chest, back, and shoulders.	Treatment depends on severity. Over-the-counter cleansers, topical medications (retinoids, benzoyl peroxide), and antibiotics may be used. In severe cases, oral medications or isotretinoin (Accutane) may be prescribed under a doctor's supervision. Maintaining a good skincare routine and a healthy diet are crucial for managing acne.

	Description	Causes	Symptoms	Treatment
<b>Eczema</b>	A condition characterized by itchy, inflamed skin patches that can develop blisters or cracks.	Eczema is a chronic inflammatory skin condition. While the exact cause is unknown, genetics, allergies, and a weakened skin barrier play a role.	Dry, itchy, red, and inflamed patches of skin are common. Eczema can flare up in response to stress, irritants (soaps, detergents), or allergens.	Moisturisers are essential to soothe and strengthen the skin barrier. Corticosteroid creams are often used to reduce inflammation and itching. In severe cases, immunosuppressant medications or light therapy may be necessary.
<b>Psoriasis</b>	A chronic autoimmune condition causing red, scaly patches on the skin.	Autoimmune. <b>Note:</b> <i>An autoimmune disease is a condition in which the immune system mistakenly attacks the body's own tissues, thinking they are foreign invaders. This can lead to inflammation, tissue damage, and impaired function of the affected organs.</i>	Raised, red, scaly patches covered with silvery white scales are characteristic. Psoriasis can appear on elbows, knees, scalp, and other body parts.	Treatment focuses on managing symptoms and preventing flare-ups. Topical medications like corticosteroids, retinoids, and vitamin D analogues are commonly used. Light therapy and oral medications may be used in more severe cases.

	Description	Causes	Symptoms	Treatment
<b>Atopic dermatitis</b>	Like eczema, atopic dermatitis is a chronic, itchy skin condition.	It's often associated with allergies and a weakened skin barrier.	Dry, itchy, red, and inflamed skin, especially on the face, hands, and feet, are common. In infants, it may appear on the cheeks and scalp.	Moisturisers are essential for managing dryness. Topical corticosteroids and anti-itching medications can help manage symptoms. It is crucial to identify and avoid triggers (allergens, irritants).
<b>Melanoma</b>	Melanoma is a type of skin cancer that develops from melanocytes, the cells responsible for producing the pigment melanin, which gives skin its colour.	Uncontrolled growth of pigment-producing cells (melanocytes) in the skin, often triggered by excessive exposure to ultraviolet (UV) radiation from the sun or tanning beds.	The appearance of a new mole or a change in an existing mole (asymmetry, irregular borders, colour variation, diameter larger than 6 mm) can be a warning sign.	Early detection is crucial. If caught early, melanoma can be treated effectively through surgical removal. In advanced stages, other therapies, like immunotherapy, may be needed. Sun protection through sunscreen, protective clothing, and avoiding peak sun hours is vital for prevention.

	Description	Causes	Symptoms	Treatment
<b>Skin rashes</b>	Skin rashes are areas of irritated or swollen skin that may be itchy, red, and sometimes painful.	<ul style="list-style-type: none"> <li>- Reactions to allergens such as certain foods, medications, insect bites, or contact with plants like poison ivy.</li> <li>- Contact with chemicals, soaps, detergents, or other substances that irritate the skin.</li> <li>- Viral, bacterial, or fungal infections can cause rashes. Examples include chickenpox, impetigo, and ringworm.</li> <li>- Heat rash occurs due to blocked sweat ducts and excessive sweating.</li> </ul>	<ul style="list-style-type: none"> <li>- Inflamed and red areas on the skin.</li> <li>- Intense itching that can be uncomfortable and persistent.</li> <li>- Swollen patches of skin.</li> <li>- Small fluid-filled blisters or raised bumps.</li> <li>- Dry, flaky, or peeling skin.</li> </ul>	<ul style="list-style-type: none"> <li>- Avoiding allergens or irritants.</li> <li>- Apply creams or ointments containing corticosteroids to reduce inflammation and itching.</li> <li>- Using moisturisers to keep the skin hydrated and prevent dryness.</li> <li>- Applying cool, damp cloths to the rash to soothe itching and reduce swelling.</li> <li>- Using prescribed medications if the rash is due to a bacterial or fungal infection.</li> <li>- Keeping the affected area clean and dry to prevent further irritation or infection.</li> </ul>

## Liver disorders

Liver disorders refer to a wide range of conditions that impair the normal function of the liver. The liver is a vital organ responsible for many critical bodily functions, including detoxification, protein synthesis, and the production of biochemicals necessary for digestion. When the liver is not functioning properly, it can affect the entire body.

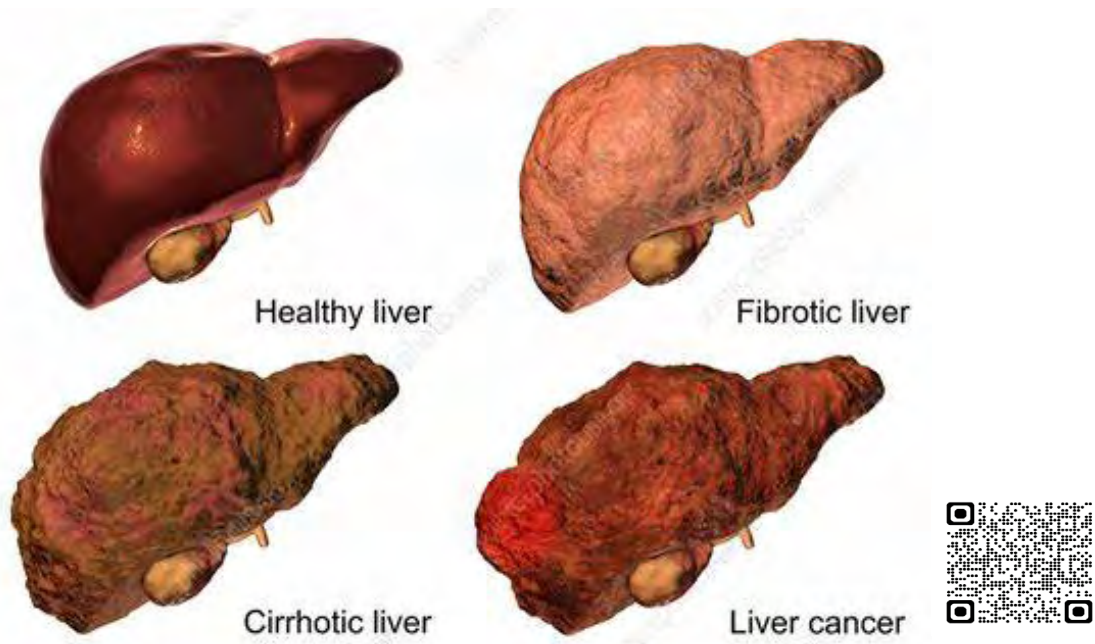

Fig.9. 4: Diagram of liver disorders

## Common liver disorders

	Description	Causes	Symptoms	Treatment
<b>Hepatitis</b>	Inflammation of the liver, often caused by viral infections (hepatitis A, B, C, D, E), but also by alcohol, drugs, and autoimmune diseases.	The most common types of viral hepatitis are Hepatitis A, B, and C. These viruses attack the liver, causing inflammation and damage. Hepatitis A is spread through contaminated food or water, while B and C are spread through bodily fluids.	Early stages often have no symptoms. In later stages, fatigue, nausea, vomiting, loss of appetite, jaundice (yellowing of the skin and eyes), dark urine, and abdominal pain may occur.	There's no cure for most viral hepatitis, but treatment focuses on managing symptoms and preventing further damage. Vaccines are available for Hepatitis A and B, and treatment for Hepatitis C involves antiviral medications.

	Description	Causes	Symptoms	Treatment
<b>Alcoholic Liver Disease (ALD)</b>		Excessive alcohol consumption over time damages liver cells, leading to inflammation, fatty buildup (steatosis), fibrosis (scarring), and cirrhosis (severe scarring).	In the early stages, there may be no symptoms. As the disease progresses, fatigue, loss of appetite, nausea, vomiting, abdominal pain, jaundice, and swelling in the legs (oedema) can occur.	The primary treatment is complete abstinence from alcohol. In some cases, medications or liver transplants may be necessary, depending on the severity of the damage.
<b>Non-Alcoholic Fatty Liver Disease (NAFLD)</b>	Accumulation of excess fat in liver cells. It includes non-alcoholic fatty liver disease (NAFLD) and alcoholic fatty liver disease (AFLD).	A buildup of fat in the liver unrelated to alcohol consumption. The exact cause is unknown, but factors like obesity, type 2 diabetes, and high cholesterol may contribute.	NAFLD often has no symptoms. In some cases, fatigue and right upper abdominal pain may occur.	Weight loss through diet and exercise is the cornerstone. Medications are still under development, but managing underlying conditions like diabetes is crucial.
<b>Autoimmune Hepatitis</b>		The immune system mistakenly attacks healthy liver cells, causing inflammation and damage. The exact cause is unknown, but genetics may play a role.	Like viral hepatitis, symptoms may include fatigue, nausea, vomiting, loss of appetite, jaundice, and abdominal pain.	Medications to suppress the immune system are the mainstay of treatment.

	Description	Causes	Symptoms	Treatment
<b>Cirrhosis</b>	Cirrhosis is an advanced stage of liver scarring (fibrosis) resulting from various liver diseases and conditions, including hepatitis and chronic alcoholism.	This is the most advanced stage of liver disease, where healthy liver tissue is replaced with scar tissue, hindering its function. It can be caused by various factors like chronic viral hepatitis, ALD, NAFLD, and certain genetic disorders.	Like other liver diseases, symptoms include fatigue, nausea, vomiting, loss of appetite, jaundice, fluid build-up (ascites), and confusion (hepatic encephalopathy).	There's no cure for cirrhosis, but treatment focuses on managing symptoms and preventing further complications. Depending on the cause, medications, lifestyle changes, and, in severe cases, a liver transplant may be considered.
<b>Liver Cancer</b>	Malignant tumours in the liver, such as hepatocellular carcinoma.	Chronic Hepatitis B or C Infections, cirrhosis, alcohol consumption, inherited liver diseases such as hemochromatosis- Consuming foods contaminated with aflatoxins, toxins produced by certain moulds, increases liver cancer risk.	Weight loss, loss of appetite, upper abdominal pain, jaundice, and a palpable mass in the upper abdomen.	Removal of the cancerous part of the liver, liver transplant, etc.

## Learning task

1. Identify the disorders of the following excretory organs:
  - a. Kidney
  - b. Skin
  - c. Liver
  
2. Explain the causes, symptoms and treatment of the disorders of the following excretory organs:
  - a. Kidney
  - b. Skin
  - c. Liver
  
3. Describe how the disorders of the following excretory organs can be treated in modern days:
  - a. Kidney
  - b. Skin
  - c. Liver

## PEDAGOGICAL EXEMPLARS

### 1. Collaborative learning

- a. Taking consideration GESI, SEL and other cross-cutting issues, put learners into mixed-ability group.

Provide each group with the tables above which describe the causes and symptoms for some excretory disorders in the human body. Do not include the treatments column.

- b. Ask learners, in their groups, to research treatments for the disorders and to fill these into the table.

Give learners a time limit to read and memorise as much of the information provided as possible, focusing on the symptoms and treatments for each disorder. Learners may wish to make flashcards or summary notes to help them to learn the facts.

### 2. Role play

- a. Begin the role play task. Ask one student to come to the front of the class to be the 'patient'. They should describe just one of their symptoms to their audience (e.g. "I have a rash on my hand"). The audience ('doctors') should take turns to ask one question to ascertain which of the disorders the patient has. They should then take turns to offer treatment advice.

- b. Keep introducing new ‘patients’ once the previous disorder has been correctly identified. Ensure that lots of different students are asked for their input, choosing less able students to ask the initial questions. Provide scaffolding support for learners who may face challenges and assign roles such as group leader and secretary to group members. This approach promotes 21st-century skills and national core values while also considering cross-cutting issues such as Gender Equality and Social Inclusion (GESI) and Social and Emotional Learning (SEL).

## KEY ASSESSMENT

**Level 1:** Identify at least three disorders of each of the following excretory organs:

- a. Kidney
- b. Skin
- c. Liver

**Level 2:** Explain the causes, symptoms and treatment of each of the disorders of the following excretory organs:

- a. Kidney
- b. Skin
- c. Liver

**Level 3:**

1. Describe how the disorder of each of the following excretory organs can be treated in modern day:
  - a. Kidney
  - b. Skin
  - c. Liver
2. Imagine you are a medical doctor specialising in nephrology (studying kidney function and diseases). You have a patient, a 50-year-old individual named Mr. Smith, who has been experiencing symptoms such as swelling in the legs, high blood pressure, and fatigue. After conducting tests, you diagnose him with chronic kidney disease (CKD).

In pairs, role-play the following scenario above:  
the nephrologist and the patient.

### Hint



The recommended mode of assessment for week 9 is **roleplay**. Use the level 3 question 2 as a sample question.

## Section 2 Review



This section provided a comprehensive exploration of the excretory system over five weeks.

The first four weeks focused on analysing the structure and function of the excretory organs, including the kidneys, lungs, skin, liver and large intestine. Learners deeply understood how these organs work together to filter blood and remove waste. We delved into the detailed waste removal processes, covering urine formation through filtration, reabsorption, secretion, and excretion, as well as the regulatory mechanisms involved.

The final week was dedicated to evaluating excretory system disorders, such as kidney stones, urinary tract infections, and chronic kidney disease. This holistic approach taught learners about the anatomy, physiological processes, and potential health issues related to the excretory system, emphasising the importance of maintaining its health for overall well-being.

## ADDITIONAL READING

1. Nephron function and urine formation
2. Segments of the liver and its excretory functions.
3. Scan the QR codes to watch videos

	
<p>Scan the QR code watch a video on how to create of liver model.</p>	<p>Scan the QR to watch videos on urine formation.</p>

## RUBRICS FOR THE PRESENTATION ASSESSMENT TASK

Criteria	Excellent (4)	Proficient (3)	Basic (2)	Needs Improvement (1)
Understanding of Concepts	<p>explanation of the excretion processes in both the lungs and large intestine depicting any 4 of these: diffusion, peristalsis, cellular respiration and waste product.</p>	<p>explanation of the excretion processes in both the lungs and large intestine depicting any 3 of these: diffusion, peristalsis, cellular respiration and waste product</p>	<p>explanation of the excretion processes in both the lungs and large intestine depicting any 3 of these: diffusion, peristalsis, cellular respiration and waste product</p>	<p>explanation of the excretion processes in both the lungs and large intestine depicting any 1 of these: diffusion, peristalsis, cellular respiration and waste product</p>
Comparison and Analysis	<p>Stating any 4 of these:</p> <ol style="list-style-type: none"> <li>Lungs excrete gaseous waste (<math>\text{CO}_2</math> and <math>\text{H}_2\text{O}</math>) while large Intestine excretes solid waste (faeces).</li> <li>Lungs <b>diffusion</b> of <math>\text{CO}_2</math> and <math>\text{H}_2\text{O}</math> from blood to alveoli while large intestine <b>absorption</b> of water, <b>compaction</b>, and <b>defecation</b>.</li> </ol>	<p>Stating any 3 of these:</p> <ol style="list-style-type: none"> <li>Lungs excrete gaseous waste (<math>\text{CO}_2</math> and <math>\text{H}_2\text{O}</math>) while large Intestine excretes solid waste (faeces).</li> <li>Lungs diffusion of <math>\text{CO}_2</math> and <math>\text{H}_2\text{O}</math> from blood to alveoli while large intestine absorption of water, compaction, and defecation.</li> </ol>	<p>Stating any 2 of these:</p> <ol style="list-style-type: none"> <li>Lungs excrete gaseous waste (<math>\text{CO}_2</math> and <math>\text{H}_2\text{O}</math>) while large Intestine excretes solid waste (faeces).</li> <li>Lungs diffusion of <math>\text{CO}_2</math> and <math>\text{H}_2\text{O}</math> from blood to alveoli while large intestine absorption of water, compaction, and defecation.</li> </ol>	<p>Stating any 1 of these:</p> <ol style="list-style-type: none"> <li>Lungs excrete gaseous waste (<math>\text{CO}_2</math> and <math>\text{H}_2\text{O}</math>) while large Intestine excretes solid waste (faeces).</li> <li>Lungs diffusion of <math>\text{CO}_2</math> and <math>\text{H}_2\text{O}</math> from blood to alveoli while large intestine absorption of water, compaction, and defecation.</li> </ol>

Criteria	Excellent (4)	Proficient (3)	Basic (2)	Needs Improvement (1)
Use of Evidence and Examples	<p>3. Lungs part of the respiratory system while large intestine part of the digestive system.</p> <p>4. Lungs waste is in gaseous form while large intestine waste is in solid form.</p>	<p>3. Lungs are part of the respiratory system while large intestine part of the digestive system.</p> <p>4. Lungs waste is in gaseous form while large intestine waste is in solid form.</p>	<p>3. Lungs part of the respiratory system while large intestine part of the digestive system.</p> <p>4. Lungs waste is in gaseous form while large intestine waste is in solid form.</p>	<p>3. Lungs part of the respiratory system while large intestine part of the digestive system.</p> <p>4. Lungs waste is in gaseous form while large intestine waste is in solid form.</p>
	<p>Stating 4 Relevant examples to support explanations such as CO<sub>2</sub> excretion for lungs, faeces formation for large intestine, water vapour, dead cells, bacteria, bile pigments, and other waste materials from the digestive process and Use of data, diagrams, or case studies to enhance understanding.</p>	<p>Stating 3 Relevant examples to support explanations such as CO<sub>2</sub> excretion for lungs, faeces formation for large intestine, water vapour, dead cells, bacteria, bile pigments, and other waste materials from the digestive process and Use of data, diagrams, or case studies to enhance understanding</p>	<p>Stating 2 Relevant examples to support explanations such as CO<sub>2</sub> excretion for lungs, faeces formation for large intestine, water vapour, dead cells, bacteria, bile pigments, and other waste materials from the digestive process and Use of data, diagrams, or case studies to enhance understanding</p>	<p>Stating 1 Relevant examples to support explanations such as CO<sub>2</sub> excretion for lungs, faeces formation for large intestine, water vapour, dead cells, bacteria, bile pigments, and other waste materials from the digestive process and Use of data, diagrams, or case studies to enhance understanding</p>

Criteria	Excellent (4)	Proficient (3)	Basic (2)	Needs Improvement (1)
Organization and Structure	Exhibit any 4 Logical flow of ideas such as a clear introduction, main body, conclusion and Seamless transitions between sections.	Exhibit any 3 Logical flow of ideas, such as a clear introduction, main body, conclusion and Seamless transitions between sections.	Exhibit any 2 Logical flow of ideas, such as clear introduction, main body, conclusion and Seamless transitions between sections.	Exhibit any 1 Logical flow of ideas such as a clear introduction, main body, conclusion and Seamless transitions between sections.
Presentation Delivery	Exhibit any 4 of these Confident and engaging delivery. Clear speech, appropriate pacing, and effective use of visual aids. Maintains eye contact and interacts with the audience.	Exhibit any 3 of these Confident and engaging delivery. Clear speech, appropriate pacing, and effective use of visual aids. Maintains eye contact and interacts with the audience.	Exhibit any 2 of these Confident and engaging delivery. Clear speech, appropriate pacing, and effective use of visual aids. Maintains eye contact and interacts with the audience.	Exhibit any 1 of these Confident and engaging delivery. Clear speech, appropriate pacing, and effective use of visual aids. Maintains eye contact and interacts with the audience.

Criteria	Excellent (4)	Proficient (3)	Basic (2)	Needs Improvement (1)
<b>Team work</b>	<p>Exhibit 4 of these</p> <p>Contributing to the group.</p> <p>Respecting the views of others</p> <p>Tolerating others</p> <p>Resolving conflicts</p> <p>Taking responsibility</p> <p>Thorough responses to audience questions.</p> <p>..</p>	<p>Exhibit 3 of these</p> <p>Contributing to the group.</p> <p>Respecting the views of others</p> <p>Tolerating others</p> <p>Resolving conflicts</p> <p>Taking responsibility</p> <p>Thorough responses to audience questions.</p>	<p>Exhibit 2 of these</p> <p>Contributing to the group.</p> <p>Respecting the views of others</p> <p>Tolerating others</p> <p>Resolving conflicts</p> <p>Taking responsibility</p> <p>Thorough responses to audience questions.</p>	<p>Exhibit 1 of these</p> <p>Contributing to the group.</p> <p>Respecting the views of others</p> <p>Tolerating others</p> <p>Resolving conflicts</p> <p>Taking responsibility</p> <p>Thorough responses to audience questions.</p>
<b>Visual Aids and Creativity</b>	<p>The visual aid shows creativity and organisation of any 4 of these: layout that draws attention to key points. Visuals are eye-catching and relevant and enhance understanding of the content. Text and images are balanced and easy to follow.</p>	<p>The visual aid shows creativity and organisation of any 3 of these: layout that draws attention to key points. Visuals are eye-catching and relevant and enhance understanding of the content. Text and images are balanced and easy to follow.</p>	<p>The visual aid shows creativity and organisation of any 2 of these: layout that draws attention to key points. Visuals are eye-catching and relevant and enhance understanding of the content. Text and images are balanced and easy to follow.</p>	<p>The visual aid shows creativity and organisation of any 1 of these: layout that draws attention to key points. Visuals are eye-catching and relevant and enhance understanding of the content. Text and images are balanced and easy to follow.</p>



## APPENDIX D: MID OF SEMESTER EXAMINATION

### The nature of the mid-semester examination

The mid-semester examination will cover weeks 1-5 and consist of three sections: A, B, and C. Section A consists of 20 objective tests, Section C consists of one compulsory practical test, and Section B consists of three essay questions.

**Resource:** Printer, A4 sheets, answer booklets, stationery, timers; for e-Assessment, consider a stable internet connection, computer, or tablet, etc.

**Duration:** 60 minutes

### Sample Task

Section A: Answer all questions in this section.

1) Objective test (20 questions covering weeks 1-5)

You are given two solutions, one with a pH of 8 and another with a pH of 4. If you were to mix equal volumes of these solutions, what is the most likely result of the pH of the resulting mixture? The pH will be

- A) lower than 4, making the mixture highly acidic.
- B) 6, indicating a neutral solution.
- C) between 4 and 8, but closer to 4 due to the stronger acidity of the original solution.
- D) higher than 8, but closer to 8, indicating a more alkaline of the original solution.

Correct Answer: C

2) **Section B: Test of practical** (one compulsory question). Answer all questions in this section.

Study the diagram carefully and answer the questions below.

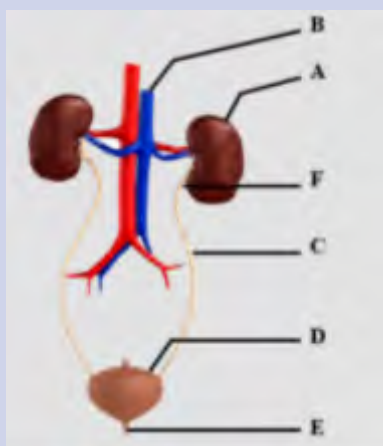

Label the part A-F

What is the unit of excretory system?

### 3) Section C: Essay type

Calculate the mass using the molar mass of NaCl ( $23.0(1) + 35.5(1) = 58.5\text{g/mol}$ ). (3 mark)

### Marking Scheme / Rubrics

#### 1. Answer to sample multiple choice question = D

Award 1 mark for each correct multiple-choice answer =20 marks

#### 2. Compulsory test of practical

Writing one-word answer correctly, such as kidney, etc. = (1 mark each)

#### 3. Essay type

Formula = (1 mark)

Substitution of numbers (1 mark)

Final answer = (1 mark)

Total marks for the test of practical= 15 marks

### Table of Specifications for week 1-5

Weeks	Focal Area(s)	Types of Questions	DoK Levels				TOTAL
			1	2	3	4	
1	Acids, Alkalis/Bases and Water	Multiple Choice	1	1	1	-	3
		Essay	-	1	-	1	2
		Test of Practical	-	2	1	-	1
2	Application of acid and bases in salt formation	Multiple Choice	2	1	-	-	3
		Essay	-	-	1	-	1
		Test of Practical	-	-	1	1	2

Weeks	Focal Area(s)	Types of Questions	DoK Levels				TOTAL
			1	2	3	4	
3	Using the pH Scale to Identify the Concentration of Acids and Bases/Alkalis solution	Multiple Choice	1	2	-	-	3
		Essay	-	-	1	-	1
		Test of Practical	-	2	1	1	2
4	pH measurement	Multiple Choice	2	1	1	-	4
		Essay	-	1	-	1	1
		Test of Practical	-	1	1	-	2
5	Understanding the Structure and Function of Human Excretory Organs	Multiple Choice	1	1	1	-	2
		Essay	1	1	-	1	1
		Test of Practical	-	2	2	-	2
		Total	8	16	4	4	30

### RubricsFor the Roleplay Assessment Task

Criteria	Excellent (4)	Proficient (3)	Basic (2)	Needs Improvement (1)
Understanding of CKD and Medical Concepts	<p>Stating any 4 of these explanation of what chronic kidney disease (CKD) is, including its stages.</p> <p>description of symptoms such as swelling, high blood pressure, fatigue) and causes such as diabetes, hypertension).</p> <p>Explanation of tests conducted such as GFR, creatinine levels, urinalysis) and their significance.</p> <p>Discussion of complications of CKD such as anaemia, bone disease, cardiovascular issues.</p> <p>Presentation of treatment options such as medication, dialysis, dietary changes.</p>	<p>Stating any 4 of these explanation of what chronic kidney disease (CKD) is, including its stages.</p> <p>description of symptoms such as swelling, high blood pressure, fatigue) and causes such as diabetes, hypertension).</p> <p>Explanation of tests conducted such as GFR, creatinine levels, urinalysis) and their significance.</p> <p>Discussion of complications of CKD such as anaemia, bone disease, cardiovascular issues.</p> <p>Presentation of treatment options such as medication, dialysis, dietary changes.</p>	<p>Stating any 4 of these explanation of what chronic kidney disease (CKD) is, including its stages.</p> <p>description of symptoms such as swelling, high blood pressure, fatigue) and causes such as diabetes, hypertension).</p> <p>Explanation of tests conducted such as GFR, creatinine levels, urinalysis) and their significance.</p> <p>Discussion of complications of CKD such as anaemia, bone disease, cardiovascular issues.</p> <p>Presentation of treatment options such as medication, dialysis, dietary changes.</p>	<p>Stating any 4 of these explanation of what chronic kidney disease (CKD) is, including its stages.</p> <p>description of symptoms such as swelling, high blood pressure, fatigue) and causes such as diabetes, hypertension).</p> <p>Explanation of tests conducted such as GFR, creatinine levels, urinalysis) and their significance.</p> <p>Discussion of complications of CKD such as anaemia, bone disease, cardiovascular issues.</p> <p>Presentation of treatment options such as medication, dialysis, dietary changes.</p>

<b>Criteria</b>	<b>Excellent (4)</b>	<b>Proficient (3)</b>	<b>Basic (2)</b>	<b>Needs Improvement (1)</b>
Role Portrayal: Nephrologist	<p>Stating any 4 of these showing confidence and expertise in diagnosing and explaining CKD.</p> <p>Avoiding overly technical jargon while ensuring accuracy.</p> <p>Empathy towards the patient's concerns, providing reassurance and understanding.</p> <p>Addressing the patient's questions and concerns thoroughly.</p> <p>Involving the patient in treatment decisions and next steps.</p>	<p>Stating any 3 of these showing confidence and expertise in diagnosing and explaining CKD.</p> <p>Avoiding overly technical jargon while ensuring accuracy.</p> <p>Empathy towards the patient's concerns, providing reassurance and understanding.</p> <p>Addressing the patient's questions and concerns thoroughly.</p> <p>Involving the patient in treatment decisions and next steps.</p>	<p>Stating any 2 of these showing confidence and expertise in diagnosing and explaining CKD.</p> <p>Avoiding overly technical jargon while ensuring accuracy.</p> <p>Empathy towards the patient's concerns, providing reassurance and understanding.</p> <p>Addressing the patient's questions and concerns thoroughly.</p> <p>Involving the patient in treatment decisions and next steps.</p>	<p>Stating any 1 of these showing confidence and expertise in diagnosing and explaining CKD.</p> <p>Avoiding overly technical jargon while ensuring accuracy.</p> <p>Empathy towards the patient's concerns, providing reassurance and understanding.</p> <p>Addressing the patient's questions and concerns thoroughly.</p> <p>Involving the patient in treatment decisions and next steps.</p>

Criteria	Excellent (4)	Proficient (3)	Basic (2)	Needs Improvement (1)
Role Portrayal: Patient	<p>Stating the any 4 of these expresses realistic emotions such as concern, confusion, fear about the diagnosis.</p> <p>Engages actively by asking relevant questions about the disease, tests, and treatment.</p> <p>Provides a detailed history when prompted such as lifestyle, symptoms duration, family history.</p> <p>Responds appropriately to the nephrologist's explanations such as seeking clarification where needed.</p> <p>Shows interest in treatment options and next steps for managing the condition</p>	<p>Stating the any 4 of these expresses realistic emotions such as concern, confusion, fear about the diagnosis.</p> <p>Engages actively by asking relevant questions about the disease, tests, and treatment.</p> <p>Provides a detailed history when prompted such as lifestyle, symptoms duration, family history.</p> <p>Responds appropriately to the nephrologist's explanations such as seeking clarification where needed.</p> <p>Shows interest in treatment options and next steps for managing the condition</p>	<p>Stating the any 4 of these expresses realistic emotions such as concern, confusion, fear about the diagnosis.</p> <p>Engages actively by asking relevant questions about the disease, tests, and treatment.</p> <p>Provides a detailed history when prompted such as lifestyle, symptoms duration, family history.</p> <p>Responds appropriately to the nephrologist's explanations such as seeking clarification where needed.</p> <p>Shows interest in treatment options and next steps for managing the condition</p>	<p>Stating the any 4 of these expresses realistic emotions such as concern, confusion, fear about the diagnosis.</p> <p>Engages actively by asking relevant questions about the disease, tests, and treatment.</p> <p>Provides a detailed history when prompted such as lifestyle, symptoms duration, family history.</p> <p>Responds appropriately to the nephrologist's explanations such as seeking clarification where needed.</p> <p>Shows interest in treatment options and next steps for managing the condition</p>

Criteria	Excellent (4)	Proficient (3)	Basic (2)	Needs Improvement (1)
Communication Skills	<p>Showing any 4 of these skills</p> <p>Audible voice, Keeping eye contact Pay attention to audience conversation, transitioning smoothly between diagnosis, explanation, and next steps. Engaging the audience with interaction Use of gesture maintaining a balance between detailed explanations and concise communication.</p>	<p>Showing any 3 of these skills</p> <p>Audible voice, Keeping eye contact Pay attention to audience conversation, transitioning smoothly between diagnosis, explanation, and next steps. Engaging the audience with interaction Use of gesture maintaining a balance between detailed explanations and concise communication</p>	<p>Showing any 2 of these skills</p> <p>Audible voice, Keeping eye contact Pay attention to audience conversation, transitioning smoothly between diagnosis, explanation, and next steps. Engaging the audience with interaction Use of gesture maintaining a balance between detailed explanations and concise communication.</p>	<p>Showing any 1 of these skills</p> <p>Audible voice, Keeping eye contact Pay attention to audience conversation, transitioning smoothly between diagnosis, explanation, and next steps. Engaging the audience with interaction Use of gesture maintaining a balance between detailed explanations and concise communication</p>

Criteria	Excellent (4)	Proficient (3)	Basic (2)	Needs Improvement (1)
Use of Empathy and Interpersonal Skills	<p>Stating any 4 of these Nephrologist acknowledges patient's emotions and provides support.</p> <p>Patient expresses vulnerability, showing trust in the nephrologist's guidance.</p> <p>Sensitivity in discussing lifestyle changes or potential outcomes, considering the patient's perspective.</p> <p>Encouragement and reassurance about the effectiveness of treatment plans.</p> <p>Building rapport by using a friendly, approachable tone to foster trust.</p>	<p>Stating any 3 of these Nephrologist acknowledges patient's emotions and provides support.</p> <p>Patient expresses vulnerability, showing trust in the nephrologist's guidance.</p> <p>Sensitivity in discussing lifestyle changes or potential outcomes, considering the patient's perspective.</p> <p>Encouragement and reassurance about the effectiveness of treatment plans.</p> <p>Building rapport by using a friendly, approachable tone to foster trust.</p>	<p>Stating any 2 of these Nephrologist acknowledges patient's emotions and provides support.</p> <p>Patient expresses vulnerability, showing trust in the nephrologist's guidance.</p> <p>Sensitivity in discussing lifestyle changes or potential outcomes, considering the patient's perspective.</p> <p>Encouragement and reassurance about the effectiveness of treatment plans.</p> <p>Building rapport by using a friendly, approachable tone to foster trust.</p>	<p>Stating any 1 of these Nephrologist acknowledges patient's emotions and provides support.</p> <p>Patient expresses vulnerability, showing trust in the nephrologist's guidance.</p> <p>Sensitivity in discussing lifestyle changes or potential outcomes, considering the patient's perspective.</p> <p>Encouragement and reassurance about the effectiveness of treatment plans.</p> <p>Building rapport by using a friendly, approachable tone to foster trust.</p>

Criteria	Excellent (4)	Proficient (3)	Basic (2)	Needs Improvement (1)
Accuracy of Medical Recommendations	<p>Showing 4 of these</p> <p>Provides clear treatment options, such as lifestyle adjustments, medications, or dialysis.</p> <p>Emphasizes importance of follow-up care, including regular monitoring and tests.</p> <p>Recommends dietary changes, such as reducing salt, protein, and potassium intake.</p> <p>Discusses potential use of medications such as antihypertensives, erythropoietin for anaemia.</p>	<p>Showing 3 of the skills</p> <p>Provides clear treatment options, such as lifestyle adjustments, medications, or dialysis.</p> <p>Emphasizes importance of follow-up care, including regular monitoring and tests.</p> <p>Recommends dietary changes, such as reducing salt, protein, and potassium intake.</p> <p>Discusses potential use of medications such as antihypertensives, erythropoietin for anaemia.</p>	<p>Showing 2 of the skills</p> <p>Provides clear treatment options, such as lifestyle adjustments, medications, or dialysis.</p> <p>Emphasizes importance of follow-up care, including regular monitoring and tests.</p> <p>Recommends dietary changes, such as reducing salt, protein, and potassium intake.</p> <p>Discusses potential use of medications such as antihypertensives, erythropoietin for anaemia.</p>	<p>Showing 1 of the skills</p> <p>Provides clear treatment options, such as lifestyle adjustments, medications, or dialysis.</p> <p>Emphasizes importance of follow-up care, including regular monitoring and tests.</p> <p>Recommends dietary changes, such as reducing salt, protein, and potassium intake.</p> <p>Discusses potential use of medications such as antihypertensives, erythropoietin for anaemia.</p>

Criteria	Excellent (4)	Proficient (3)	Basic (2)	Needs Improvement (1)
Creativity and Realism of Scenario	<p>The role plays shows creativity and organisation of any 4 of these: Develops a believable dialogue, reflecting a realistic doctor-patient interaction.</p> <p>Incorporates realistic test results and medical history details to enrich the scenario.</p> <p>Uses props or visual aids (e.g., charts, mock test reports) to simulate a real consultation.</p> <p>Creates realistic patient reactions, including emotional and logical responses to the diagnosis.</p> <p>Ensures continuity, with actions and dialogue aligned with the scenario's context.</p>	<p>The role plays shows creativity and organisation of any 4 of these: Develops a believable dialogue, reflecting a realistic doctor-patient interaction.</p> <p>Incorporates realistic test results and medical history details to enrich the scenario.</p> <p>Uses props or visual aids (e.g., charts, mock test reports) to simulate a real consultation.</p> <p>Creates realistic patient reactions, including emotional and logical responses to the diagnosis.</p> <p>Ensures continuity, with actions and dialogue aligned with the scenario's context.</p>	<p>The role plays shows creativity and organisation of any 4 of these: Develops a believable dialogue, reflecting a realistic doctor-patient interaction.</p> <p>Incorporates realistic test results and medical history details to enrich the scenario.</p> <p>Uses props or visual aids (e.g., charts, mock test reports) to simulate a real consultation.</p> <p>Creates realistic patient reactions, including emotional and logical responses to the diagnosis.</p> <p>Ensures continuity, with actions and dialogue aligned with the scenario's context.</p>	<p>The role plays shows creativity and organisation of any 4 of these: Develops a believable dialogue, reflecting a realistic doctor-patient interaction.</p> <p>Incorporates realistic test results and medical history details to enrich the scenario.</p> <p>Uses props or visual aids (e.g., charts, mock test reports) to simulate a real consultation.</p> <p>Creates realistic patient reactions, including emotional and logical responses to the diagnosis.</p> <p>Ensures continuity, with actions and dialogue aligned with the scenario's context.</p>

# SECTION 3: GASEOUS EXCHANGE IN HUMANS

## Strand: Processes for living

### Sub-strand: Essentials for survival

**Learning Outcome:** *Recognise and explain that the energy released during respiration drives processes in the human body.*

**Content Standard:** Demonstrate knowledge and ability to research how air moves in and out of humans.

#### Hint



Remind learners of the end of semester examination in week 12. Refer to Appendix D at the end of this section for Table of specification.

## INTRODUCTION AND SECTION SUMMARY

The human respiratory system is essential for life, facilitating the exchange of gases such as oxygen and carbon dioxide. This section explores air movement through the nose, trachea, and into the lungs, where the branching airways and alveoli enable the exchange of gases. Aerobic respiration, in which cells convert glucose and oxygen into energy, carbon dioxide, and water, is central to the respiratory system's function. However, the respiratory system can be affected by various disorders, such as asthma and lung cancer, which can impair the proper functioning of the lungs and lead to health complications.

The weeks covered by the section are:

Week 10: *Explain, with diagrams, the concept of the movement of air in humans and its importance.*

Week 11: *Describe the structure of the lungs and investigate the products of aerobic respiration.*

Week 12: *Discuss disorders associated with the respiratory system.*

## SUMMARY OF PEDAGOGICAL EXEMPLARS

This section offers a variety of interactive and project-based learning activities to deepen learners' understanding of the respiratory system. The proposed learning activities

encompass various engaging, learner-centred approaches to help learners develop a deep understanding of the human respiratory system. These exemplars highlight the importance of activity-based learning, where learners work in mixed-ability groups to label, explain, and create visual representations of the air movement pathway. Collaborative learning experiences encourage learners to research, discuss, and critically analyse the respiratory system's functions, such as gas exchange and cellular respiration. Simulations and demonstrations using anatomical models, videos, and hands-on activities allow learners to explore the structure of the lungs and mimic the mechanics of breathing. Additionally, role-play, conceptual modelling, and think-pair-share activities facilitate understanding the complex processes involved in aerobic respiration and the impact of respiratory disorders, fostering a comprehensive and engaging learning experience.

## ASSESSMENT SUMMARY

Assessments within this framework encompass formative, summative, and differentiated approaches to evaluate student learning comprehensively. Formative assessments encompass lab work, short tests, group projects, and presentations to enhance science process skills and gauge understanding. Conversely, summative assessments are conducted at the end of the lesson, section, or semester, contributing to cumulative records. Learners can self-assess learning outcomes by coding them red (not understood), amber (partially understood), or green (well understood). This system aids in tracking progress and addressing areas for improvement effectively.

Creating a conducive assessment environment entails providing clear instructions and maintaining consistency for all participants to uphold fairness. Emphasising the application of knowledge, critical thinking, problem-solving, and effective communication in assessments ensures a holistic evaluation of learners' aptitudes. Differentiated assessments cater to individual learner needs, with gifted learners receiving challenging tasks, enriching activities, or accelerated learning options. Transcript recording is vital to document learner characteristics, assessment details, and additional observations for a comprehensive evaluation overview.

Tailoring assessments to accommodate diverse learning needs, strengths, and interests ensures that all learners can showcase their skills equally. By adapting assessment content to various readiness levels and preferences, teachers should foster an inclusive learning environment that nurtures each student's capabilities to their fullest potential.

Teachers can consult the Teacher Assessment Manual and Toolkits (TAMT) (NaCCA, MoE, 2003) for guidance on effectively utilising various assessment strategies.

**WEEK 10**

**Learning Indicator:** Explain, with diagrams, the concept of the movement of air in humans and its importance.

## FOCAL AREA: MOVEMENT OF AIR IN HUMANS AND ITS IMPORTANCE

### Breathing

Breathing is the process of taking air in and out of the lungs. It is an essential bodily function that allows the body to take in oxygen and remove carbon dioxide. Breathing involves air movement through the nose or mouth, down the trachea, and into the lungs, where gas exchange occurs. This exchange of oxygen and carbon dioxide is vital for the body to function and produce energy.



**Fig. 10.1:** A diagram showing Breathing in air

### Processes and structures involved in the movement of air

- 1. Pharyngeal Cavities:** Air enters the pharyngeal cavities through the mouth and nose. The pharyngeal passages humidify the air because atmospheric air can be too dry for humans. The nasal passage is lined with ciliated cells that help filter dust, bacteria, and viruses from the inspired atmospheric air. Mucous membranes in the nasal and oral passages humidify inspired air and act as an immunological barrier to trap dust and bacteria.
- 2. Trachea:** The trachea, a cartilaginous tube, serves as the primary airway in vertebrate organisms, providing a pathway for air to enter and leave the lungs.
- 3. Bronchi and Bronchioles:** The trachea divides into two bronchi, major extensions that transport air to and from the lungs. Both bronchi and bronchioles have specialised goblet and ciliated cells to filter dust and pathogens. They are supported by cartilaginous rings to prevent collapse.

4. **Bronchioles:** Bronchi are divided into numerous bronchioles, with small extensions that branch off into different lung regions, forming the bronchial tree.
5. **Alveoli:** Finally, inhaled air from the bronchioles enters the air-sacs (alveoli) for gaseous exchange.

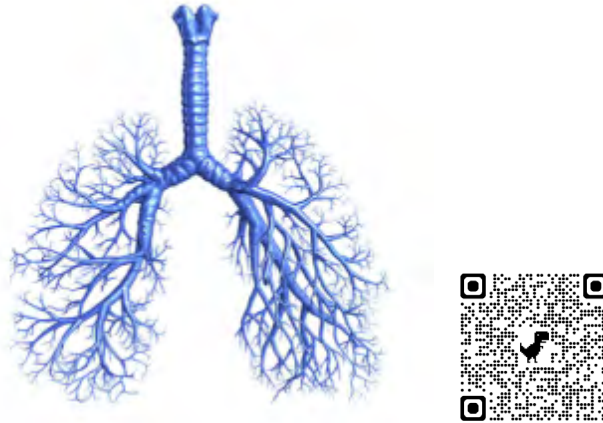

Fig.10.2 : A diagram of the bronchial tree of the lungs

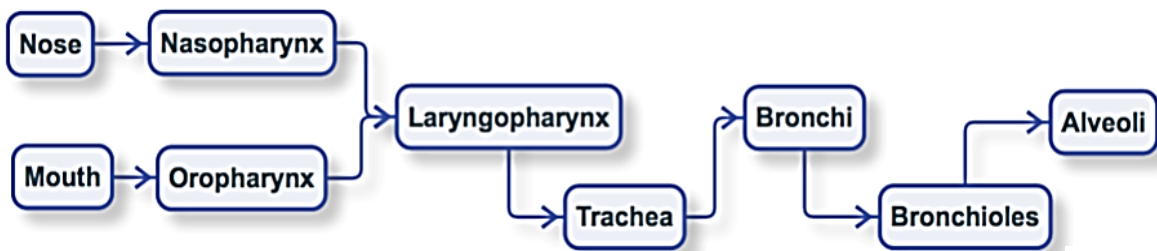

Fig. 10.3a: A concept map of air pathways through the lungs

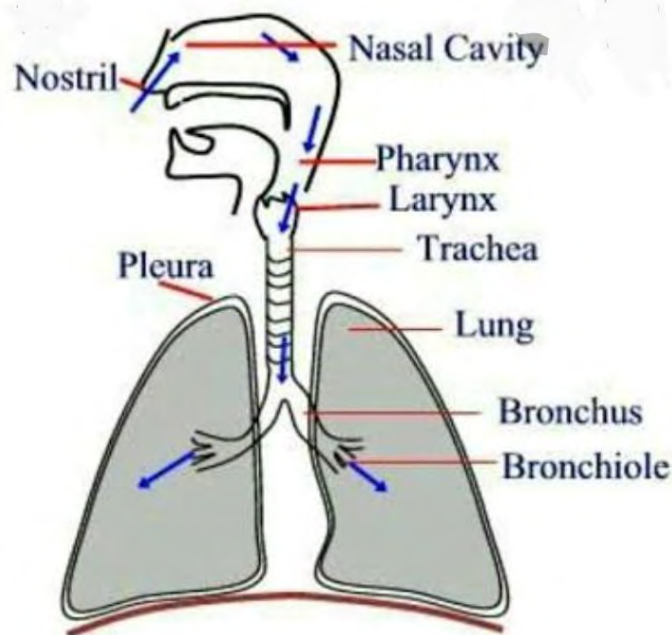

Fig. 10.3b: A diagram showing the respiratory pathways

## Mechanism of inhalation in humans

Inhalation is the process of drawing air into your lungs. It's a crucial part of the respiratory system, allowing oxygen to enter your body and carbon dioxide to be expelled.

1. **Contraction of the diaphragm muscle:** The diaphragm, a dome-shaped muscle located at the base of the lungs, contracts during inhalation. As the diaphragm contracts, it moves downward, increasing the volume of the thoracic cavity.
2. **Expansion of the thoracic cavity:** The downward movement of the diaphragm increases the volume of the thoracic cavity. This increase in volume leads to a decrease in the pressure inside the thoracic cavity.
3. **Air flow into the lungs:** The decrease in pressure inside the thoracic cavity creates a partial vacuum, drawing air into the lungs. Air flows from an area of high pressure (outside the body) to an area of low pressure (inside the lungs).
4. **Inflation of the lungs:** As air flows into the lungs, the alveoli (tiny air sacs) expand, increasing the surface area for gas exchange. Oxygen-rich air is then transported to the bloodstream through the alveolar-capillary membrane.

## Mechanism of exhalation in humans

Exhalation is the process of releasing air from your lungs. It's the counterpart to inhalation and is just as important for maintaining proper respiratory function.

1. **Relaxation of the diaphragm muscle:** After inhalation, it relaxes, allowing it to move upward.
2. **Contraction of the abdominal muscles:** The abdominal muscles contract, pushing the abdominal contents upward, causing the diaphragm to move upward.
3. **Decrease in the thoracic cavity volume:** The upward movement of the diaphragm and the contraction of the abdominal muscles decrease the thoracic cavity volume.
4. **Increase in the pressure inside the thoracic cavity:** The decrease in the thoracic cavity volume leads to an increase in the pressure inside the thoracic cavity.
5. **Air flow out of the lungs:** The pressure inside the thoracic cavity causes air to be pushed out of the lungs.  
Air flows from an area of high pressure (inside the lungs) to an area of low pressure (outside the body).
6. **Expulsion of carbon dioxide:** The air expelled from the lungs contains a higher concentration of carbon dioxide, which is then released from the body.

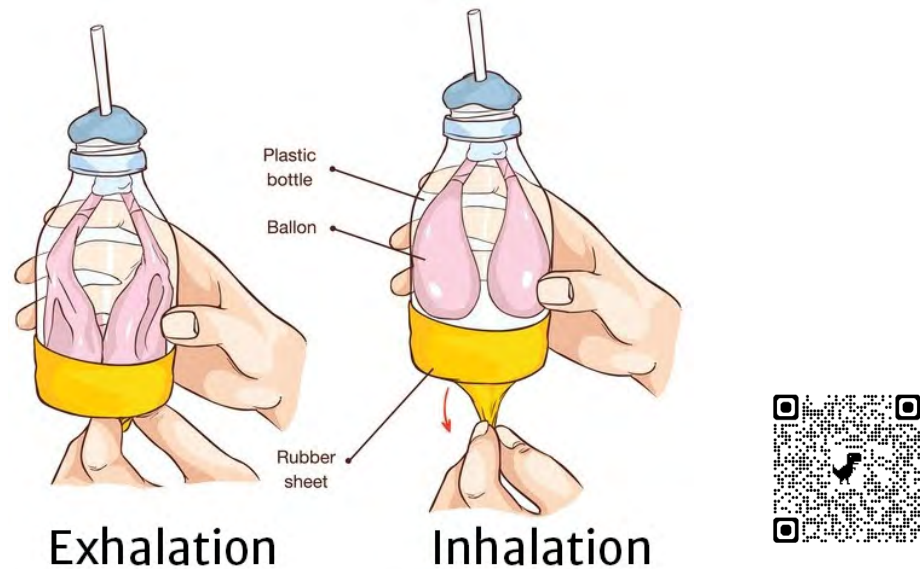

**Fig. 10. 4:** A diagram of the mechanism of Inhalation and Exhalation

**Table 10.1:** Difference between inhalation and exhalation

Aspect	Inhalation (Inspiration)	Exhalation (Expiration)
<b>Muscles Involved</b>	Diaphragm (contracts and moves downward), External intercostal muscles (contract)	Typically, passive (no active muscle contraction in resting state)
<b>Volume Changes</b>	The thoracic cavity expands (increases in width and length)	Thoracic cavity decreases
<b>Lung Volume</b>	Increases	Decreases
<b>Intrapulmonary Pressure</b>	Decreases	Increases
<b>Air Movement</b>	Air moves into the lungs (due to lower intrapulmonary pressure compared to atmospheric pressure)	Air moves out of the lungs (due to higher intrapulmonary pressure compared to atmospheric pressure)
<b>Energy Requirement</b>	Active process; requires energy (ATP)	Typically passive at rest; no energy requirement
<b>Muscle Involvement</b>	Diaphragm and external intercostal muscles	None in resting state; internal intercostal and abdominal muscles for forced expiration
<b>Mechanical Action</b>	Active contraction of muscles	Passive relaxation of muscles
<b>Role in Breathing Cycle</b>	Initiates the respiratory cycle	Concludes the respiratory cycle

## EXPERIMENT 10.1 – Experiment modelling the excretion of waste by the lungs

**Aim:** To demonstrate how lungs inflate and deflate with air.

**Apparatus:** Plastic bottle, two balloons (blue and pink), a rubber band, straw, tape, scissors.

### Procedure

- i. Cut the bottom off a plastic bottle.
- ii. Stretch one blue balloon over the cut edge of the bottle and secure it with a rubber band. This represents the diaphragm.
- iii. Insert a straw into the pink balloon and tape it securely. Insert the straw and pink balloon into the neck of the bottle so that the balloon is inside the bottle and the straw sticks out.
- iv. Seal the neck of the bottle around the straw with modelling clay or tape.
- v. Pull the diaphragm blue balloon (at the bottom) gently down to inflate the pink balloon inside the bottle, demonstrating how the diaphragm moves to allow air into the lungs.

### Observation and explanation

This activity simulates the basic mechanics of breathing. Pulling down on the blue balloon expands the chest cavity, like how the diaphragm muscle contracts during inhalation. Releasing your grip allows the balloon to shrink, mimicking exhalation as the diaphragm relaxes. The straw represents the trachea, which carries air to and from the lungs.



**Fig. 10.5:** Diagram showing excretion of waste by the lungs

## EXPERIMENT 10.2 – Experiment to create a respiratory system model

**Apparatus:** Plastic bottle with screw top cap, three pieces of drinking straws, three rubber bands, tape, three balloons, plastic wrap, scissors, knife/nails

### Procedures

1. Choose your bottle; make sure it is big enough to hold the size of your balloons.
2. Cut around the bottom of your bottle with scissors to have enough room lengthwise for the straw.
3. Carefully using your knife/nail, cut a hole roughly the size of your straw.
4. Use 2 or 3 straws for this step. First, if you have bending straws, cut them slightly after the bend in the straw so you can still bend it.
5. Cut about 3 inches off one side and keep one of the longer lengths of the straws. Then, cut to have a slit to place the smaller straw pieces into.
6. Make sure the smaller pieces fit how you want them to, and that air can be blown through and out of both ends.
7. Tape the pieces together so there is no excess air able to go through the slits. Remember not to be too tight, or it will constrict airflow. This structure will be our trachea, or windpipe, that brings air into the body. It divides into the left and right bronchi, continuing the air's travel into our lungs.
8. Take your two balloons and use your scissors to cut the top of the balloon off. The balloons are the part of the model that make up the outer part of your lungs.
9. Take one balloon, insert one side of your windpipe (straw) into it, and, using tape, lightly wrap the balloon around the straw, making sure there is no obstruction to airflow.
10. Repeat with the other balloon and side of the windpipe. This way, air will travel safely through each bronchus and into the alveoli sacs.
11. Put your lungs into your bottle by inserting your lungs straw side up into the bottle.
12. Take your lid and put the top of your windpipe (straw) through the hole. Screw the lid back onto the bottle and lightly tape around the hole to make it airtight.
13. Stretch one red balloon over the mouth of the bottle and secure it with a rubber band. This represents the diaphragm. In our model, the red balloon represents the diaphragm. Our diaphragm tightens and flattens, allowing us to suck air into our lungs.

14. Pull your red balloon down to contract the diaphragm and make your lungs inhale the air. Release your grip and allow the lungs to exhale.



**Fig. 10.6:** *Diagram showing respiration in the lungs*

## Importance of air movement in humans

The importance of air movement in humans is vital for maintaining proper respiratory function and overall health.

### 1. Oxygen supply

- a. Inhalation brings oxygen-rich air into the lungs, which is absorbed into the bloodstream.
- b. Oxygen is essential for cellular respiration, providing the energy needed for the body's various functions.

### 2. Carbon dioxide removal

- a. Exhalation removes carbon dioxide from the body, a waste product of cellular respiration.
- b. Efficient air movement ensures that carbon dioxide levels in the body are kept within a healthy range, preventing build-up and potential health issues.

### 3. Respiratory homeostasis

- a. Air movement helps maintain the body's balance of gases (oxygen and carbon dioxide), which is crucial for preserving the body's pH and other physiological parameters.

- b. Disruptions in air movement can lead to respiratory disorders, such as hypoxia (low oxygen levels) or hypercapnia (high carbon dioxide levels).

#### 4. Lung function

- a. Regular air movement helps to keep the lungs healthy and functioning optimally.
- b. It prevents the build-up of mucus and other respiratory secretions, which can impair lung function if not cleared.

#### 5. Immune system support

- a. Air movement helps to filter and remove airborne pathogens, such as bacteria and viruses, from the respiratory system.
- b. This protects the body from respiratory infections and supports the overall immune system.

#### 6. Physical and mental well-being

- a. Efficient air movement can improve physical performance by delivering more oxygen to the muscles.
- b. It can also reduce stress and anxiety by triggering the relaxation response associated with deeper, slower breathing patterns.

### Learning Tasks

1. Define the term “breathing” and its purpose in the human body.
2. Describe the mechanism of inhalation and exhalation.
3. Explain the importance of air movement in the human body.
4. Demonstrate the mechanism of breathing using a simple respiratory system model.

## PEDAGOGICAL EXEMPLARS

### 1. Collaborative learning

- a. Engage learners and encourage critical thinking and reflection by posing open-ended questions such as “Why is oxygen important for our bodies?” or “What happens if we do not breathe properly?”.

Let learners in pairs think-ink and share the open-ended questions.

- b. Put learners in mixed-ability groups and let them discuss the pathway of air through the human body as it is inhaled and exhaled. Ask them to create a flow-chart of this pathway, adding as much detail as they can before talking them through the correct answer using visual aids to support. Encourage learners to explain the pathway of air using arrows or lines on their diagrams/models.

- c. Facilitate a class discussion about the importance of the movement of air in humans.
- d. Task learners in mixed ability groups to explore the mechanism of inhalation and exhalation and to draw diagrams illustrating their findings.
- e. Provide scaffolding support for learners who may face challenges and assign roles such as group leader and secretary to group members. This approach promotes 21st-century skills and national core values, while also considering cross-cutting issues such as Gender Equality and Social Inclusion (GESI) and Social and Emotional Learning (SEL)

## 2. Activity-based learning

- a. Put learners into mixed groups for a hands-on activity and guide them to create simple models using materials such as balloons and straws to show gaseous exchange by the lungs. Allow learners to cross-reference their models and discuss. Note: experiment 1 and experiment 2 outlined above both demonstrate the same concept and so only one should be performed.

Learners should be encouraged to generate their version of the “function” of each structure after reading the required materials rather than it being given to them. This can be scaffolded (for lower-ability learners) using pre-made definitions that need to be matched instead of generated.

- b. Provide scaffolding support for learners who may face challenges and assign roles such as group leader and secretary to group members. This approach promotes 21st-century skills and national core values while also considering cross-cutting issues such as Gender Equality and Social Inclusion (GESI) and Social and Emotional Learning (SEL)

## KEY ASSESSMENT

**Level 1:** Explain the term breathing.

**Level 2:** Describe the mechanisms of inhalation and exhalation with relevant real-life examples.

**Level 3:** Create a concept map of air movement in the human body.

### Hint



The recommended mode of assessment for week 10 is **essay type**. Use the level 2 question as a sample question.

**WEEK 11**

**Learning indicator:** Describe the structure of the lungs and investigate the products of aerobic respiration.

## FOCAL AREA 1: STRUCTURE OF THE LUNGS AND AEROBIC RESPIRATION

### Structure of the lungs

Lungs are the respiratory organs in our body. All the gas exchange in our body occurs in the lungs. Normally, humans have two lungs; left and right. They inhale oxygen ( $O_2$ ) and exhale carbon dioxide ( $CO_2$ ). Lungs play a major role in supplying oxygen to our body, without which we would be dead in a minute. The lung contains the following parts: trachea, alveoli and bronchi and pleura.

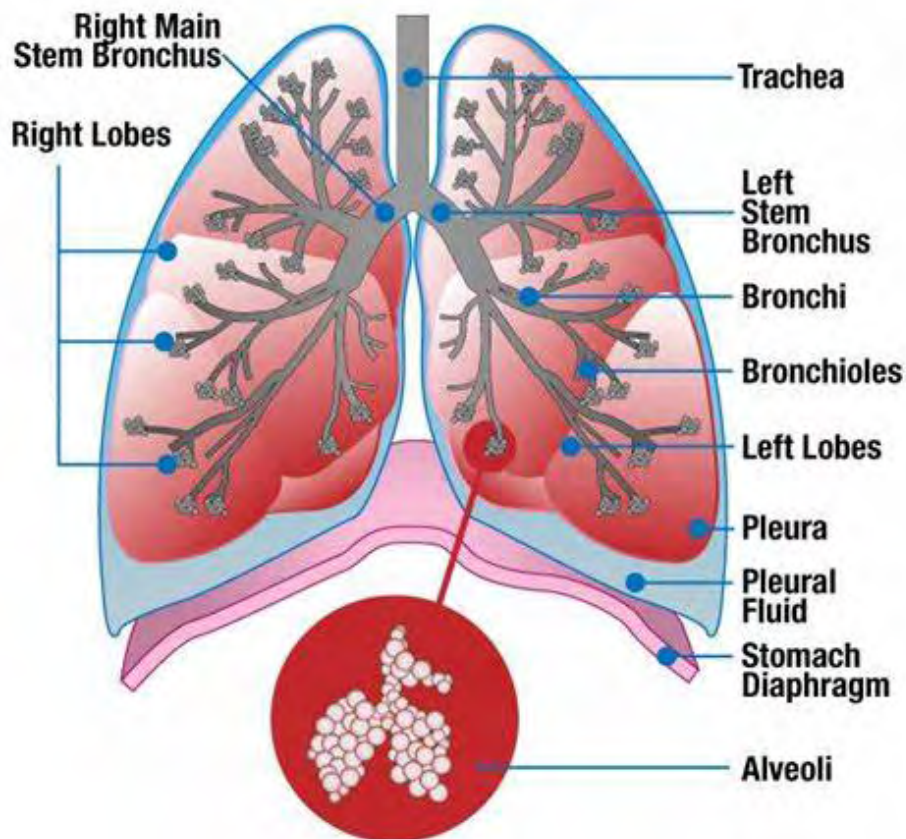

**Fig. 11.1:** A well-labelled diagram of the lung.

## Functions of the parts of the structure of the lungs

**Table 11.1:** *Parts of the lungs and their function*

Lung Part	Function
<b>Trachea</b>	A cartilaginous tube serving as the primary airway, facilitating the passage of air to and from the lungs.
<b>Bronchi</b>	Major extensions of the trachea that transport air directly to the lungs; lined with goblet and ciliated cells, supported by cartilaginous rings to prevent collapse.
<b>Bronchioles</b>	Small, fine extensions of the bronchi that branch into different regions of the lungs; part of the bronchial tree.
<b>Pharyngeal Cavities</b>	Includes oropharynx, nasopharynx, and laryngopharynx; humidifies inspired air and filters out dust and pathogens.
<b>Nasal Passage</b>	Lined with ciliated cells and mucous membranes that humidify air and act as an immunological barrier to trap dust and bacteria
<b>Alveoli</b>	These are the tiny air sacs at the end of the bronchioles, like a cluster of microscopic balloons. They have a massive surface area, ideal for gas exchange. Thin walls of the alveoli allow oxygen from inhaled air to diffuse into the bloodstream, while carbon dioxide from the blood diffuses out for exhalation
<b>Pleura</b>	It is a double-layered membrane that surrounds the lungs like a thin sac. It produces a lubricating fluid between the layers, allowing the lungs to smoothly expand and contract during breathing. This also creates a slight vacuum, helping the lungs adhere to the chest wall.
<b>Diaphragm</b>	This dome-shaped muscle separates the chest cavity from the abdominal cavity. It plays a crucial role in breathing by contracting and relaxing. When the diaphragm contracts, it pulls the lungs downward, increasing the chest cavity volume, which creates a low-pressure area. Air rushes in to fill the lungs (inhalation). When the diaphragm relaxes, the chest cavity volume decreases, pushing air out of the lungs (exhalation).

## Adaptations of the trachea

**Tracheal cartilage:** To prevent collapse, the tracheal walls are strengthened with specialised rings of cartilage known as tracheal cartilage.

**Goblet cells:** The tracheal walls are lined with goblet cells that secrete mucus to trap dust and pathogens.

**Ciliated cells:** The trachea is lined with ciliated cells to trap dust and pathogens further.

**Table 11.2:** Features associated with different parts of the lungs

Parts of the lungs	Cartilage muscle	Smooth muscle	Goblet cells	Ciliated cells
<b>Trachea</b>	Large C-shaped	Yes	Yes	Yes
<b>Bronchi</b>	Small	Yes	Yes	Yes
<b>Large bronchiole</b>	None	Yes	Yes	Yes
<b>Medium bronchiole</b>	None	Yes	No	Yes
<b>Small bronchiole</b>	None	No	No	No
<b>Alveoli</b>	None	No	No	No

## Location of lungs

The lungs are located on both sides of the chest within the thoracic cavity, with one lung on each side of the mediastinum above the diaphragm. They are encased in a pleural sac and shielded by the rib cage. Based on their position in the body, the lungs are called the left and right lungs. It should be noted that this means “patient left” and “patient right”, the left lung is the lung on the “patients” left side.

## Aerobic respiration

Aerobic respiration is a metabolic process in which cells use oxygen to convert glucose and other nutrients into adenosine triphosphate (ATP), the primary energy carrier. This process occurs in the mitochondria (within cells) and involves several stages, including glycolysis, the Krebs cycle, and the electron transport chain. Aerobic respiration is highly efficient, producing a large amount of ATP compared to anaerobic (without oxygen) respiration, and its byproducts are carbon dioxide and water.

### Overall equation of aerobic respiration

The equation for aerobic respiration describes the reactants and products of all of its steps, including glycolysis. That equation is:



In summary, one molecule of six-carbon glucose and six oxygen molecules are converted into six molecules of carbon dioxide, six molecules of water, and 38 molecules of ATP.

### *Importance of aerobic respiration*

- 1. Energy production:** The main function of aerobic respiration is to produce ATP, the cell's primary energy currency. ATP powers various cellular processes, such as muscle contraction, protein synthesis, and cell division. Aerobic respiration is highly efficient, producing up to 36-38 ATP molecules from a single glucose molecule, compared to only 2 ATP molecules produced by anaerobic respiration.
- 2. Carbon dioxide and water production:** It converts glucose and oxygen into carbon dioxide and water, then expelled from the body as waste products. This helps maintain the body's acid-base balance as carbon dioxide dissolved in the bloodstream will turn it more and more acidic as the concentration increases.
- 3. Heat production:** The process generates heat as a byproduct, which helps maintain body temperature in warm-blooded animals.

## Difference between breathing and respiration

While both breathing and respiration are essential for life, they are distinct processes:

**Table 11.3:** *Difference between breathing and respiration.*

Aspect	Breathing	Respiration
<b>Definition</b>	The physical process of inhaling and exhaling air	The biochemical process of releasing energy from food molecules
<b>Process</b>	Involves the exchange of gases (O <sub>2</sub> and CO <sub>2</sub> ) between the organism and the environment	It involves chemical reactions, mainly oxidation of glucose, to produce energy.
<b>Location</b>	Takes place in the respiratory organs (lungs, gills, etc.).	It takes place in the cells, specifically in the mitochondria.
<b>Voluntary/ Involuntary</b>	Partially voluntary (e.g., can hold breath) but mostly involuntary.	Completely involuntary; controlled by cellular needs
<b>Purpose</b>	To bring oxygen into the body and remove carbon dioxide	To generate energy (ATP) required for cellular activities.
<b>Oxygen Involvement</b>	Oxygen is inhaled into the lungs.	Oxygen is used to oxidise glucose in cells.

Aspect	Breathing	Respiration
<b>Carbon Dioxide</b>	Carbon dioxide is exhaled out of the lungs	Carbon dioxide is produced as a waste product of cellular respiration
<b>Energy Requirement</b>	Does not produce energy but requires energy to function (muscle movement).	Produces energy in the form of ATP.
<b>Examples</b>	Breathing in humans involves the diaphragm and intercostal muscles	Aerobic respiration, anaerobic respiration (e.g., fermentation).

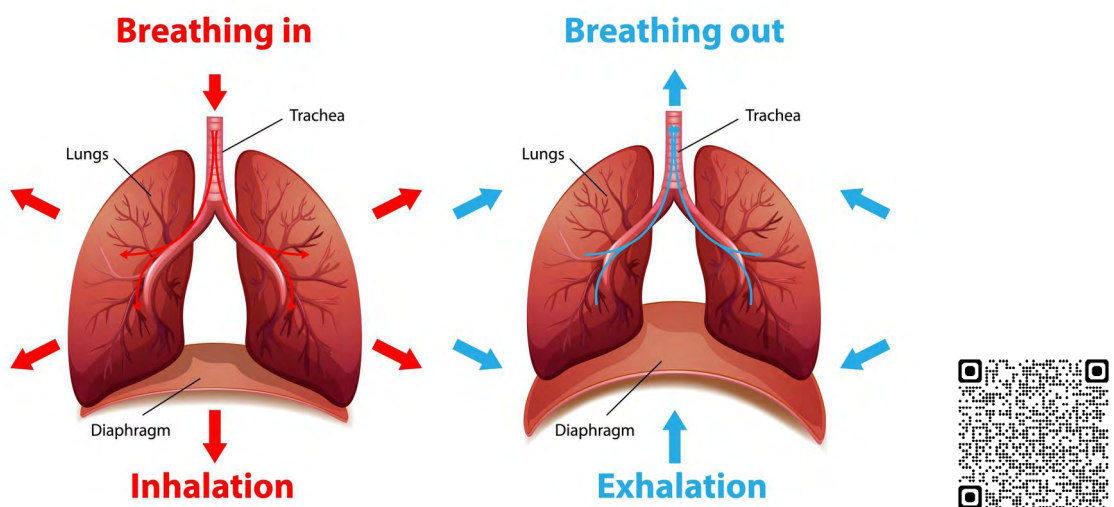

Fig. 11.2: A diagram of the breathing process.

### Learning Task

1. Identify the parts of the lungs.
2. Describe the structure of the lungs.
3. Explain aerobic respiration and write its balanced chemical equation.
4. Explain at least three differences between breathing and respiration.

## PEDAGOGICAL EXEMPLARS

### 1. Talk-for-learning / Collaborative learning

- a. Allow learners in pair or small groups to draw the respiratory structure and label the parts. Organise a gallery walk where learners peer-review their work. Provide learners with definitions of key terms such as alveoli, bronchioles, goblet cells, cilia.

- b.** Ask learners to discuss the following:
- Which parts of the system are likely to be made of firm cartilage?
  - Which parts are likely to be flexible and elastic?
  - Which parts might contain goblet cells or cilia?

Confirm the correct answers after some class discussion.

- c.** Put learners into mixed-ability groups and guide them to define aerobic and anaerobic respiration for the learners. Encourage learners to work collaboratively to explore the products of aerobic respiration, including ATP, carbon dioxide, and water, and the role of mitochondria in this process.
- Task each group produce summary notes to submit for peer review.
- d.** Task learners in pairs to create concept maps or diagrams, labelling key components and explaining the differences between respiration (cellular) and breathing for whole-class presentation.
- e.** Provide scaffolding support for learners who may face challenges and assign roles such as group leader and secretary to group members. This approach promotes 21st-century skills and national core values, while also considering cross-cutting issues such as Gender Equality and Social Inclusion (GESI) and Social and Emotional Learning (SEL)

## **2. Experiential learning**

- a.** Provide learners with anatomical models, videos/animations, and charts/diagrams to illustrate the structure of the lungs, including the trachea, bronchi, bronchioles, alveoli, and the surrounding blood vessels. Task learners in their group to identify the parts of the lungs.
- b.** Guide learners to perform a full lung dissection. The lungs (in their entirety) can be obtained from an animal and then the use of bike pump can show the learners inflating and deflating.
- c.** Provide scaffolding support for learners who may face challenges and assign roles such as group leader and secretary to group members. This approach promotes 21st-century skills and national core values, while also considering cross-cutting issues such as Gender Equality and Social Inclusion (GESI) and Social and Emotional Learning (SEL).

## KEY ASSESSMENT

**Level 1:** Identify at least four parts of the lungs.

**Level 2:** Describe the structure of the lungs

**Level 3**

1. Write a balanced chemical equation for aerobic respiration and describe the role of the mitochondria in this process.
2. Construct a model of the structure of the lungs.

### Hint



The recommended mode of assessment for week 11 is **practical**. Use the level 3 question 2 as a sample question.

**WEEK 12**

**Learning Indicator:** *Explain, with diagrams, the concept of the movement of air in humans and its importance.*

## **FOCAL AREA: EFFECT OF SMOKE AND COMMON RESPIRATORY DISORDERS AND THEIR IMPACT ON HEALTH**

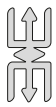

### **Note**

Care should be taken when delivering this section in case learners have been directly affected by a smoking death in their immediate family, learners may also be distressed if their parents are smokers when they are learning this section

### **Explanation of the term ‘disorder’**

In health and medicine, a disorder is a condition or a set of symptoms that deviates from normal or healthy functioning. It is a state of being that differs from an individual’s typical or expected state, often resulting in impairment, distress, or disability.

Disorders can occur in various aspects of a person’s life, including physical, mental, emotional, and behavioural. They can range in severity from mild and manageable to severe and life-threatening and can significantly impact an individual’s overall well-being and quality of life.

### **Effects of vaping on the structure of the lungs**

Vaping involves using an electronic device, often referred to as a vape pen or e-cigarette, to inhale vapour produced from a liquid. This liquid, commonly known as e-liquid or vape juice, typically contains nicotine, flavourings, and other chemicals. The device heats the liquid to create a vapor that is then inhaled. Vaping is often marketed as an alternative to smoking traditional cigarettes.

Vaping can have several effects on the lungs, some of which include:

1. **Respiratory irritation:** Vaping can cause irritation in the respiratory system, leading to coughing, throat irritation, and shortness of breath.
2. **Inflammation:** Chemicals in e-liquids can cause inflammation in the lungs, which may contribute to respiratory issues and diseases.
3. **Lung damage:** Certain chemicals in vape liquids, such as diacetyl, can cause serious lung damage, including a condition known as “popcorn lung” (bronchiolitis obliterans).

4. Increased risk of infections: Vaping can impair the immune response in the lungs, making them more susceptible to infections like pneumonia.
5. Potential for chronic conditions: Long-term vaping may increase the risk of developing chronic lung conditions such as chronic bronchitis and possibly chronic obstructive pulmonary disease (COPD).

## Effects of smoking on the structure of the lungs

Smoking has a profound and damaging impact on the structure and function of the lungs. When an individual inhales cigarette smoke, the harmful chemicals and toxins present in the smoke directly affect the delicate tissues and structures within the lungs. Over time, this can lead to significant changes in the lung's architecture, seriously affecting an individual's respiratory health.

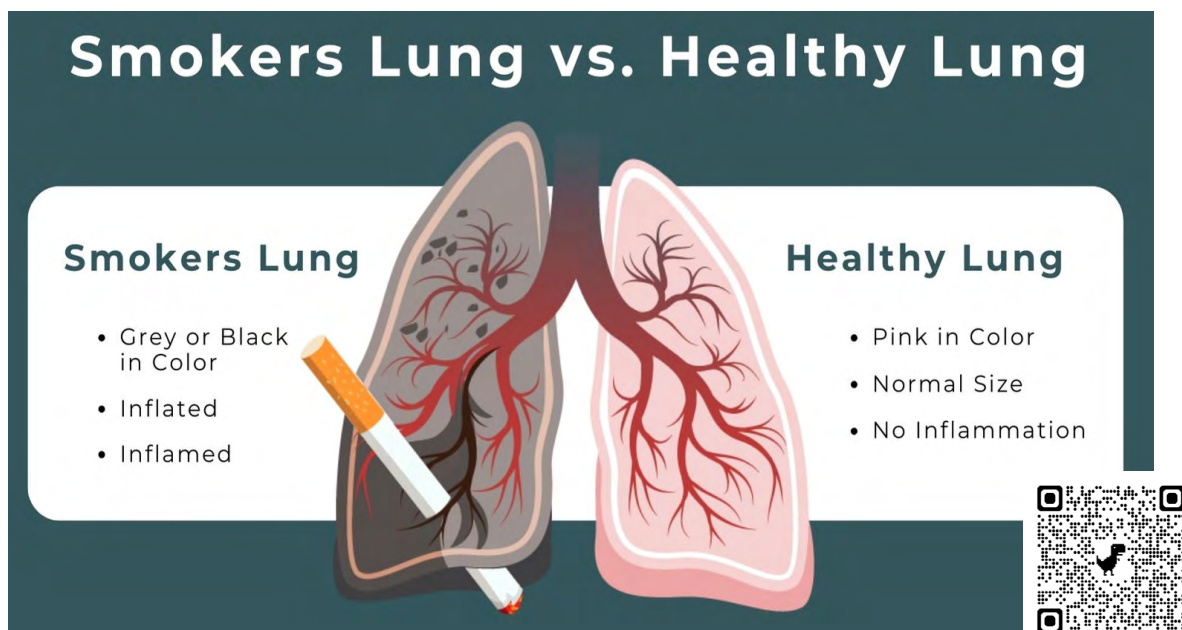

**Fig. 12.1:** A diagram showing smokers' lung versus healthy lung

Smoking can have several effects on the lungs, some of which include:

1. **Damage to the alveoli:** The alveoli are the tiny air sacs in the lungs where oxygen and carbon dioxide exchange. Smoking can damage and lose the alveoli's elasticity, making it harder for the lungs to function properly.  
 Example: Emphysema, a chronic obstructive pulmonary disease (COPD), is characterised by the destruction and enlargement of the alveoli, reducing the lung's ability to exchange gases efficiently.
2. **Inflammation and irritation:** Cigarette smoke contains numerous irritants and inflammatory agents that can inflame the airways and lung tissue, leading to swelling and increased mucus production.

Example: Chronic bronchitis, a type of COPD, is characterised by persistent inflammation and excess mucus production in the airways, making breathing harder.

3. Thickening of the airway walls: Smoking can cause the walls of the airways to thicken, reducing their diameter and making it more difficult for air to flow through.

Example: Asthma, a chronic respiratory condition, can be exacerbated by smoking, as the thickened airway walls can make it harder for the lungs to expand and contract during breathing.

4. Fibrosis and scarring: Repeated exposure to the harmful chemicals in cigarette smoke can lead to the formation of scar tissue within the lungs, a process known as fibrosis.

Example: Idiopathic pulmonary fibrosis (IPF) is a progressive lung disease characterised by the gradual scarring and stiffening of the lung tissue, making it increasingly difficult to breathe.

## EXPERIMENT 12.1 – Experiment to show the effects of smoking on lung function

**Title:** The effects of smoking on lung function

**Aim:** To demonstrate the effects of smoking on lung function

**Apparatus:** Two balloons (one representing healthy lungs, one representing smoker's lungs), straws, cotton balls (optional), timer, large container (optional)

### Procedure

1. Stretch one balloon slightly to represent healthy, elastic lungs.
2. Stuff the other balloon with a few cotton balls (to simulate tar build-up) and stretch it less than the first one, representing the decreased elasticity of the smoker's lungs.
3. Attach a straw to each balloon.
4. Ask learners to take turns "breathing" through the straws for a set amount of time (e.g., 30 seconds) into the balloons.
5. You can use a large container to simulate an enclosed space filled with smoke for the smoker's lung simulation (optional).

### Observation

After the set time, ask learners to observe the size of each balloon.

The healthy lung balloon should be significantly inflated, while the smoker's lung balloon will be less inflated due to the cotton balls restricting expansion.

Discuss the difficulty of “breathing” through the straw with the cotton balls, and how this relates to the struggle smokers experience due to damaged lung tissue.

### Explanation

This experiment simulates how healthy lungs expand easily with air during inhalation, while smoker’s lungs with tar buildup become less elastic and struggle to take in enough Oxygen.

The cotton balls represent tar and other harmful chemicals from cigarettes that damage the alveoli (air sacs) in the lungs, reducing their efficiency in gas exchange.

### Conclusion

This experiment has demonstrated the significant impact smoking has on lung function. The healthy lung balloon easily inflated, representing the efficient intake of air during breathing. Conversely, the smoker’s lung balloon, restricted by the cotton balls, showed a reduced capacity for expansion. This simulates how tar buildup from cigarettes damages and stiffens the alveoli in real lungs, hindering their ability to take in Oxygen.

Through this activity, we can conclude that smoking significantly reduces lung capacity, making it more difficult to breathe. This limited Oxygen intake has detrimental effects on overall health and stamina.

## EXPERIMENT 12.2 – Experiment to show the devastating effects of smoking on the lungs

**Aim:** Demonstrating the effect of smoke on the lungs

**Apparatus:** Two clear plastic bottles (1-litre size), balloons, a piece of clear plastic tubing, modelling clay or playdough, a small amount of cotton, lighter or matches, incense sticks or a small piece of paper to burn, rubber bands, scissors, tape

### Procedure

- a. Cut the bottoms off both plastic bottles.
- b. Insert a balloon into the neck of each bottle and stretch its opening over the neck. Secure it with a rubber band if necessary.
- c. These balloons represent the lungs.
- d. Insert a piece of clear plastic tubing through the neck of each bottle so that one end is inside the balloon and the other extends outside the bottle.
- e. Seal around the neck with modelling clay to prevent air leakage.

- f. Stretch another balloon over the cut bottom of each bottle and secure it with a rubber band. This balloon represents the diaphragm.
- g. Tape a small piece of cotton to the end of the plastic tubing outside one bottle. This cotton will trap particles from the smoke, simulating the effect of inhaling smoke.
- h. Light an incense stick or a small piece of paper to create smoke.
- i. Have one group gently pull on the diaphragm balloon to simulate inhalation and observe how the lung balloon inflates.

Now, bring the lit incense stick or burning paper near the cotton on the smoking simulation bottle and allow the smoke to be drawn in as the diaphragm is pulled. Observe and compare the differences in the lung balloons after several inhalation cycles.

### Observation and analysis

After the experiment, remove the cotton from the tubing and observe any discolouration or residue from the smoke particles.

## EXPERIMENT 12.3 – Modelling the effects of smoking (see video link)

<https://science.cleapss.org.uk/resource/the-smoking-machines-demonstration.vid>



## Asthma

<b>Symptoms</b>	<p>Asthma is a chronic respiratory condition characterised by the following symptoms:</p> <ol style="list-style-type: none"> <li>a. Wheezing: A whistling or high-pitched sound that occurs when breathing, especially during exhalation.</li> <li>b. Shortness of Breath: Difficulty taking deep breaths or feeling like you can't get enough air.</li> <li>c. Chest Tightness: A feeling of pressure or discomfort in the chest, making breathing difficult.</li> </ol>
-----------------	---

	<p>d. Coughing: Persistent, frequent coughing, often worse at night or early morning.</p> <p>These symptoms can vary in intensity and may come and go, depending on the individual and the triggers that may be present.</p>
<b>Causes</b>	<p>A combination of genetic and environmental factors causes asthma:</p> <ol style="list-style-type: none"> <li>a. Genetic factors: Asthma tends to run in families, suggesting a genetic component. Certain genetic variations can make individuals more susceptible to developing asthma.</li> <li>b. Environmental triggers: Exposure to various substances or environmental conditions can trigger asthma symptoms. Common triggers include: <ol style="list-style-type: none"> <li>i. Allergens (e.g., pollen, dust mites, pet dander)</li> <li>ii. Irritants (e.g., cigarette smoke, strong odours, air pollution)</li> <li>iii. Physical exertion or exercise</li> <li>iv. Respiratory infections (e.g., common cold, flu)</li> <li>v. Stress and emotional factors</li> </ol> </li> </ol>
<b>Effects</b>	<p>Asthma can have significant effects on an individual's health and quality of life:</p> <ol style="list-style-type: none"> <li>a. Impaired Lung Function: Asthma can cause inflammation and narrowing of the airways, making it difficult for the lungs to function properly, leading to breathing difficulties.</li> <li>b. Increased Risk of Exacerbations: Asthma can cause sudden, severe episodes called asthma attacks or exacerbations, which can be life-threatening if not properly managed.</li> <li>c. Disruption of Daily Activities: Asthma symptoms can interfere with daily activities, such as physical exercise, sleep, and productivity, impacting an individual's overall quality of life.</li> <li>d. Long-Term Lung Damage: Uncontrolled or severe asthma can lead to permanent scarring and remodelling of the airways, further compromising lung function over time.</li> </ol> <p><i>Example: A student with asthma may struggle to participate in physical education classes due to shortness of breath and wheezing and may experience disruptions in sleep and difficulty concentrating in class due to persistent coughing or chest tightness.</i></p>

<b>Prevention</b>	<ul style="list-style-type: none"> <li>a. Avoid asthma triggers (e.g., allergens, air pollution, exercise, stress)</li> <li>b. Maintain a healthy lifestyle with regular physical activity and a balanced diet</li> <li>c. Get vaccinated against influenza and pneumococcal diseases to prevent respiratory infections</li> <li>d. Use dust-proof bedding and keep the home clean to reduce exposure to dust mites.</li> </ul>
<b>Treatment</b>	<ul style="list-style-type: none"> <li>a. Quick-relief medications (e.g., bronchodilators) to open airways and relieve symptoms during asthma attacks</li> <li>b. Controller medications (e.g., inhaled corticosteroids) to reduce inflammation and prevent symptoms</li> <li>c. Avoid exposure to triggers</li> <li>d. Maintain good respiratory hygiene (e.g., using a spacer with inhalers)</li> </ul> <p>Seek medical attention for severe or persistent symptoms.</p>

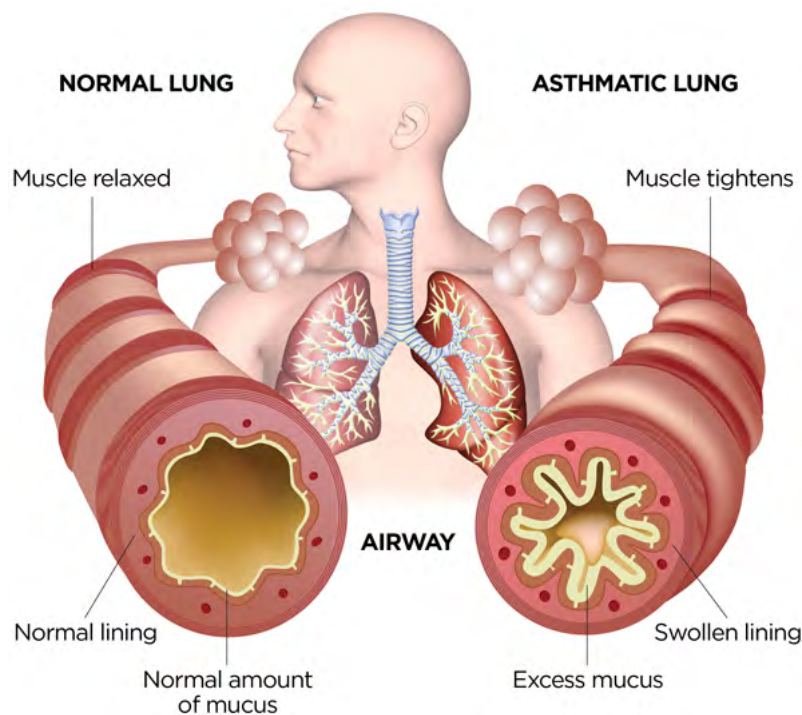

**Fig. 12.3:** diagram showing normal and asthmatic lungs.

## Chronic Obstructive Pulmonary Disease (COPD)

<p><b>Symptoms</b></p>	<p>COPD is a chronic, progressive lung disease that is characterised by the following symptoms:</p> <ol style="list-style-type: none"> <li>a. <b>Shortness of Breath:</b> Difficulty breathing, especially during physical activity, is a hallmark symptom of COPD. As the disease progresses, shortness of breath can occur even at rest.</li> <li>b. <b>Persistent Cough:</b> A chronic, productive cough that brings up mucus or phlegm is a common symptom of COPD. The cough may be worse in the morning or during the winter months.</li> <li>c. <b>Wheezing:</b> A whistling or high-pitched sound when breathing caused by the narrowing of the airways.</li> <li>d. <b>Chest Tightness:</b> A feeling of pressure or tightness in the chest, which can be especially noticeable during physical activity.</li> <li>e. <b>Fatigue:</b> COPD can cause extreme tiredness and a lack of energy, even after rest.</li> </ol>
<p><b>Causes</b></p>	<p>The primary cause of COPD is long-term exposure to irritants that damage the lungs, with the most common cause being:</p> <ol style="list-style-type: none"> <li>a. <b>Smoking:</b> Cigarette smoking is the leading cause of COPD, accounting for approximately 85-90% of all cases. The harmful chemicals in tobacco smoke can severely damage the lungs over time.</li> <li>b. <b>Other potential causes and risk factors for COPD include:</b> <ol style="list-style-type: none"> <li>i. Second-hand smoke exposure</li> <li>ii. Air pollution (indoor and outdoor)</li> <li>iii. Occupational exposure to dust, chemicals, or fumes</li> <li>iv. Genetic factors, such as alpha-1 antitrypsin deficiency</li> <li>v. Recurrent respiratory infections.</li> </ol> </li> </ol>
<p><b>Effects</b></p>	<p>COPD can have significant and far-reaching effects on an individual's health and quality of life, including:</p> <ol style="list-style-type: none"> <li>a. <b>Decreased Lung Function:</b> COPD causes a progressive decline in the lungs' ability to function properly, leading to difficulty breathing and decreased Oxygen levels in the blood.</li> </ol>

	<p>b. Exacerbations: People with COPD may experience periods of worsening symptoms, called exacerbations, which can be triggered by infections, air pollution, or other factors. These exacerbations can be life-threatening and require hospitalisation.</p> <p>c. Comorbidities: COPD is often associated with other health conditions, such as heart disease, lung cancer, depression, and anxiety, which can further complicate the management of the disease.</p> <p>d. Reduced Quality of Life: COPD’s physical limitations and emotional burden can significantly impact an individual’s ability to perform daily activities, maintain social connections, and enjoy a good quality of life.</p> <p>e. Increased Mortality: COPD is a leading cause of death worldwide, with a mortality rate that has been steadily increasing over the years.</p> <p><i>Example: A middle-aged individual who has been a heavy smoker for decades may develop COPD, experiencing persistent coughing, wheezing, and shortness of breath, even during light physical activity. As the disease progresses, they may have frequent exacerbations that require hospitalization, and they may also develop heart problems or depression, further compromising their overall health and quality of life.</i></p>
<b>Prevention</b>	<p>a. Quit smoking/vaping and avoid second-hand smoke exposure</p> <p>b. Reduce exposure to air pollutants and occupational dusts/fumes</p> <p>c. Get vaccinated against influenza and pneumococcal diseases</p> <p>d. Maintain a healthy lifestyle with regular physical activity and a balanced diet.</p>
<b>Treatment</b>	<p>a. Bronchodilators (short-acting and long-acting) to open airways and improve breathing</p> <p>b. Inhaled corticosteroids to reduce airway inflammation</p> <p>c. Oxygen therapy for severe COPD to improve Oxygen levels in the blood</p> <p>d. Pulmonary rehabilitation programs to improve exercise tolerance and quality of life</p> <p>e. Surgery (e.g., lung transplant, lung volume reduction) for severe, end-stage COPD.</p>

## Pneumonia

<p><b>Symptoms</b></p>	<p>Pneumonia is an infection of the lungs that can cause a range of symptoms, including:</p> <ol style="list-style-type: none"> <li>a. Cough: A persistent cough, often accompanied by the production of mucus or phlegm, which may be yellow, green, or even bloody.</li> <li>b. Difficulty Breathing: Shortness of breath, especially during physical activity or while at rest.</li> <li>c. Chest Pain: A sharp or stabbing pain in the chest, which may worsen with deep breathing or coughing.</li> <li>d. Fever and Chills: High body temperature, along with shivering and feeling cold.</li> <li>e. Fatigue: Extreme tiredness and a lack of energy.</li> </ol> <p>The specific symptoms can vary depending on the type of pneumonia, the causative pathogen, and the individual's overall health.</p>
<p><b>Causes</b></p>	<p>Pneumonia can be caused by a variety of microorganisms, including:</p> <ol style="list-style-type: none"> <li>a. Bacteria: Common bacterial causes of pneumonia include <i>Streptococcus pneumoniae</i>, <i>Haemophilus influenzae</i>, and <i>Mycoplasma pneumoniae</i>.</li> <li>b. Viruses: Viruses, such as influenza, respiratory syncytial virus (RSV), and SARS-CoV-2 (the virus that causes COVID-19), can also lead to pneumonia.</li> <li>c. Fungi: In some cases, pneumonia can be caused by fungal infections, particularly in individuals with weakened immune systems.</li> <li>d. Factors that can increase the risk of developing pneumonia include:             <ol style="list-style-type: none"> <li>i. Weakened immune system (e.g., due to underlying health conditions or medications)</li> <li>ii. Chronic respiratory diseases (e.g., COPD, asthma)</li> <li>iii. Smoking or vaping</li> <li>iv. Aspiration of foreign objects or fluids</li> <li>v. Recent viral or bacterial infections.</li> </ol> </li> </ol>

<b>Effects</b>	<p>Pneumonia can have serious and potentially life-threatening effects, including:</p> <ol style="list-style-type: none"> <li>1. <b>Respiratory distress:</b> The infection can cause the lungs to become inflamed and filled with fluid, making it difficult for the body to get the oxygen it needs.</li> <li>2. <b>Hospitalisation:</b> Severe cases of pneumonia often require hospitalisation for intensive treatment, including oxygen therapy, antibiotics, and, in some cases, mechanical ventilation.</li> <li>3. <b>Complications:</b> Pneumonia can lead to complications, such as empyema (accumulation of pus in the pleural space), lung abscess, or respiratory failure.</li> <li>4. <b>Long-Term effects:</b> Recovery from pneumonia can be slow, and some individuals may experience long-term respiratory issues or a decreased quality of life, especially if the pneumonia was severe or had underlying health conditions.</li> </ol> <p><i>Example: A student with a weakened immune system due to a recent illness may develop pneumonia after catching a viral infection. They may experience a high fever, severe cough, and difficulty breathing, leading to hospitalisation and the need for intensive medical treatment.</i></p>
<b>Prevention</b>	<ol style="list-style-type: none"> <li>a. Get vaccinated against pneumococcal and influenza viruses</li> <li>b. Maintain good hand hygiene and respiratory etiquette</li> <li>c. Avoid smoking/vaping and excessive alcohol consumption</li> <li>d. Manage underlying health conditions (e.g., chronic heart or lung disease, diabetes).</li> </ol>
<b>Treatment</b>	<ol style="list-style-type: none"> <li>a. Antibiotics to treat the underlying bacterial or viral infection</li> <li>b. Supportive care (e.g., fluids, oxygen therapy) to manage symptoms</li> <li>c. Hospitalisation for severe or high-risk cases</li> <li>d. Antiviral medications for pneumonia caused by influenza viruses.</li> </ol>

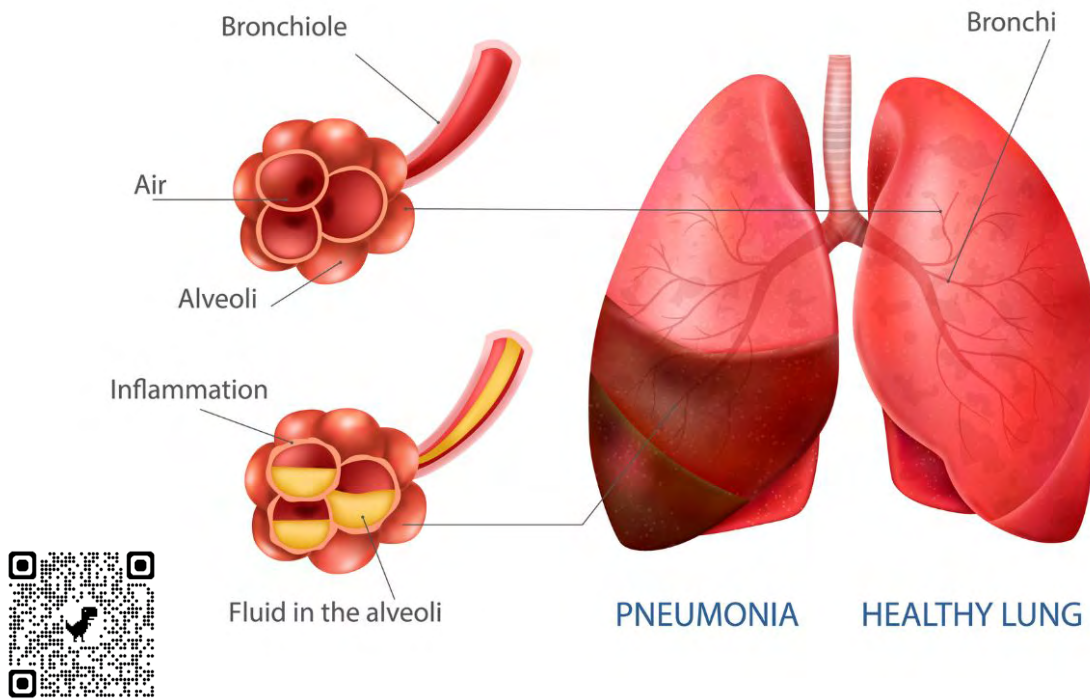

**Fig. 12.4:** A diagram of a pneumonia lung.

## Tuberculosis

Tuberculosis is an infectious disease that primarily affects the lungs but can also spread to other body parts.

<p><b>Symptoms</b></p>	<ol style="list-style-type: none"> <li>Persistent cough: A cough that lasts for more than three weeks, often accompanied by the production of sputum (phlegm) or even blood.</li> <li>Chest pain: Individuals with TB may experience chest pain, especially when breathing deeply or coughing.</li> <li>Fatigue and weakness: TB can cause a general feeling of tiredness and lack of energy.</li> <li>Fever and chills: Individuals with TB often experience intermittent fever, sometimes with night sweats.</li> <li>Weight loss: Unintentional weight loss is a common symptom of TB, especially in advanced cases.</li> <li>Loss of appetite: TB can decrease appetite and difficulty maintaining a healthy weight.</li> </ol>
------------------------	---

<b>Causes</b>	Bacterial transmission: Tuberculosis (TB) spreads through the air when a person with active TB in their lungs or throat coughs, sneezes, speaks, or sings. Tiny droplets containing the bacteria can remain suspended in the air for several hours, infecting others who inhale them.
<b>Effects</b>	<p>Tuberculosis can have serious long-term effects on an individual's health and well-being if left untreated. Some of the potential effects of TB include:</p> <ol style="list-style-type: none"> <li>Lung damage: Untreated TB can lead to permanent lung damage, such as scarring and cavities, impairing respiratory function.</li> <li>Disseminated disease: In some cases, TB can spread to other parts of the body, such as the brain, kidneys, or spine, leading to more severe and life-threatening complications.</li> <li>Death: If left untreated, TB can be a fatal disease, especially in individuals with a weakened immune system.</li> <li>Social and economic impacts: TB can have significant social and economic impacts on individuals and communities, leading to lost productivity, increased healthcare costs, and social stigma.</li> </ol> <p>It's important to note that TB is a treatable and curable disease, and early diagnosis and proper treatment are essential for preventing the spread of the disease and minimising its long-term effects.</p>
<b>Prevention</b>	<ol style="list-style-type: none"> <li>Bacille Calmette-Guérin (BCG) vaccine for high-risk populations</li> <li>Early detection and treatment of active TB cases to prevent transmission</li> <li>Improvement of living conditions and nutrition to enhance immune function</li> <li>Infection control measures in healthcare settings.</li> </ol>
<b>Treatment</b>	<ol style="list-style-type: none"> <li>Standard anti-tuberculosis drug regimen (e.g., isoniazid, rifampicin, pyrazinamide, ethambutol)</li> <li>Directly observed treatment, short-course (DOTS) to ensure adherence</li> <li>Treatment of drug-resistant TB with second-line and third-line anti-TB drugs</li> <li>Supportive care (e.g., nutrition, management of side effects).</li> </ol>

## Lung Cancer

<p><b>Symptoms</b></p>	<p>Lung cancer can present a variety of symptoms, depending on the type and stage of the cancer. The most common symptoms include:</p> <ol style="list-style-type: none"> <li>a. Persistent cough: A cough lasting more than a few weeks or becoming more severe over time.</li> <li>b. Coughing up blood: Coughing up small amounts of blood or rust-coloured phlegm.</li> <li>c. Shortness of breath: Difficulty in breathing, especially during physical activity.</li> <li>d. Chest pain: A dull, aching pain in the chest, particularly when breathing deeply or coughing.</li> <li>e. Hoarseness of voice: Changes in the voice or difficulty speaking.</li> <li>f. Unexplained weight loss: Unintentional weight loss without a change in diet or exercise habits.</li> </ol>
<p><b>Causes</b></p>	<p>The primary cause of lung cancer is exposure to certain risk factors, the most significant of which is:</p> <ol style="list-style-type: none"> <li>a. Smoking: Tobacco smoking is the leading cause of lung cancer, responsible for about 80-90% of all cases. The chemicals in tobacco smoke can damage the lungs and cause genetic mutations that lead to cancer.</li> <li>b. Other risk factors for lung cancer include:             <ol style="list-style-type: none"> <li>i. Second-hand smoke exposure</li> <li>ii. Vaping</li> <li>iii. Radon gas exposure</li> <li>iv. Asbestos exposure</li> <li>v. Air pollution</li> <li>vi. Family history of lung cancer</li> <li>vii. Previous lung diseases, such as COPD.</li> </ol> </li> </ol>
<p><b>Effects</b></p>	<p>Lung cancer can have serious and wide-ranging effects on an individual's health and quality of life, including:</p> <ol style="list-style-type: none"> <li>a. Impaired lung function: The tumour growth and spread can impair the lungs' ability to function properly, leading to breathing difficulties and reduced oxygen intake.</li> </ol>

	<p>b. <b>Metastatic spread:</b> Lung cancer can spread (metastasize) to other parts of the body, such as the brain, bones, or liver, causing additional complications and reducing the chances of survival.</p> <p>c. <b>Treatment side effects:</b> The treatments for lung cancer, such as chemotherapy, radiation, and surgery, can cause side effects like fatigue, nausea, and weakened immune system.</p> <p>d. <b>Reduced quality of life:</b> The physical and emotional toll of lung cancer can significantly impact an individual's ability to perform daily activities, maintain social connections, and enjoy a good quality of life.</p> <p>e. <b>Increased risk of mortality:</b> Lung cancer is one of the deadliest forms of cancer, with a 5-year survival rate of only about 19% for all stages combined.</p> <p><i>Example: A former smoker in their 50s may develop lung cancer that initially causes a persistent cough and shortness of breath. As the cancer progresses, it may spread to the brain, causing headaches and cognitive difficulties. The individual may undergo radiation therapy and chemotherapy, which can lead to fatigue and a weakened immune system, further compromising their quality of life.</i></p>
<b>Prevention</b>	<p>a. Quit smoking/vaping and avoid second-hand smoke exposure</p> <p>b. Reduce exposure to other lung cancer risk factors (e.g., radon, asbestos)</p> <p>c. Maintain a healthy lifestyle with regular physical activity and a balanced diet</p> <p>d. Get regular lung cancer screenings (e.g., low-dose CT scans) for high-risk individuals</p>
<b>Treatment</b>	<p>a. Surgery to remove the tumour (for early-stage lung cancer)</p> <p>b. Chemotherapy and/or radiation therapy to kill cancer cells</p> <p>c. Targeted therapies and immunotherapies to target specific genetic mutations or boost the immune system</p> <p>d. Palliative care to manage symptoms and improve quality of life</p>



**Fig. 12.5:** A diagram showing a cancerous lung

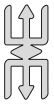

### NOTE

*Remember, preventing and treating these respiratory diseases involves a comprehensive approach, including lifestyle modifications, vaccination, early detection, appropriate medical treatment, and ongoing management. It's important to consult healthcare professionals for personalised guidance and care.*

### Learning Tasks

1. Identify the disorders of the lungs.
2. Describe the causes and symptoms of disorders of the respiratory system and how they can be treated in modern day.
3. Describe the effects of smoking on the respiratory system.

## PEDAGOGICAL EXEMPLARS

### 1. Collaborative Learning

- a. Put learners into mixed groups based on their level of understanding or interest. Let each group focus on a specific disorder, such as lung cancer, pneumonia, asthma, or tuberculosis.
  - Task learners in their mixed groups and guide them to explore causes, symptoms and treatment of the respiratory disorders. Encourage them to create presentations or posters showcasing their understanding and development.
- b. Provide learners with a worksheet giving a selection of statements from 'patients' as a doctor's surgery. These statements should describe some or all of their symptoms and could refer to genetic or environmental factors that may have affected them. Using the tables given above, learners should write a summary of their diagnosis and treatment advice for each patient.

- c. Provide scaffolding support for learners who may face difficulties and assign group members roles such as group leader, secretary, etc. to promote 21st-century skills and national core values among learners, taking into consideration cross-cutting issues such as GESI, SEL, etc.

## 2. Talk-for-learning

- a. Show visual aids such as before-and-after images of smoker's lungs compared to healthy lungs. Let learners think individually about the changes smoking causes in lung structure and function. Let learners discuss smoking and its effects on the respiratory system.
- b. Pair them up to share their insights and discuss the broader impacts of smoking on overall health. Provide needed support for learners taking into consideration GESI, SEL and other cross-cutting issues.
- c. For gifted learners, task them with further exploration and offer them extension activities such as researching emerging treatments for respiratory disorders or investigating environmental factors affecting lung health. Taking into consideration all cross-cutting issues, offer needed support to learners.

## KEY ASSESSMENT LEVEL

**Level 1:** Identify at least four disorders of the respiratory system

**Level 2:** Describe at least three effects of smoking on the respiratory system.

**Level 3:** Describe at least three causes, and symptoms each of the respiratory system's disorders and how they can be treated in the modern day.

### Hint



The recommended mode of assessment for week 12 is **end of semester examination**.

Refer to **Appendix D** at the end of this section for Table of specification.





## Section 3 Review

In this section, we explored the details of the human respiratory system. We began by examining air movement in humans, detailing the processes of inhalation and exhalation through the diaphragm and intercostal muscles and emphasising its importance for oxygen supply and carbon dioxide removal. We then delved into the structure of the lungs, focusing on the trachea, bronchi, bronchioles, and alveoli, and investigated the products of aerobic respiration—ATP, water, and carbon dioxide—highlighting their roles in energy production and waste elimination. Lastly, we discussed respiratory system disorders such as asthma,

chronic obstructive pulmonary disease (COPD), and pneumonia, covering their causes, symptoms, and treatments, and underscoring their impact on respiratory efficiency and overall health. This comprehensive review provided a clear understanding of respiratory mechanics, lung anatomy, cellular respiration, and respiratory health challenges.

## ADDITIONAL READING

Watch the videos and discuss it with learners

<ul style="list-style-type: none"> <li>• Scan the QR code for video showing the passage of air through the respiratory system</li> </ul>	
<ul style="list-style-type: none"> <li>• Scan the QR code for a video on the respiratory system model</li> </ul>	
<ul style="list-style-type: none"> <li>• Scan the QR code for video showing the passage of air through the respiratory system</li> </ul>	
<ul style="list-style-type: none"> <li>• Scan the QR code to watch a video of the mechanism of inhalation and exhalation.</li> </ul>	

## RUBRICS FOR THE ESSAY TYPE ASSESSMENT TASK

Criteria	Excellent (4 Marks)	Very Good (3 Marks)	Good (2 Marks)	Fair (1 Mark)
Content Accuracy and Completeness	<p>Showing any 4 of these:</p> <p>a. Inhalation process is clearly explained, including the role of the diaphragm, intercostal muscles, and pressure changes.</p> <p>b. Exhalation process is accurately described, detailing how muscles relax and thoracic pressure increases.</p> <p>c. Includes a thorough explanation of gas exchange in the alveoli (oxygen intake, carbon dioxide release).</p> <p>d. Describes the nervous system's role in controlling breathing such as medulla oblongata.</p>	<p>Showing any 3 of these:</p> <p>a. Inhalation process is clearly explained, including the role of the diaphragm, intercostal muscles, and pressure changes.</p> <p>b. Exhalation process is accurately described, detailing how muscles relax and thoracic pressure increases.</p> <p>c. Includes a thorough explanation of gas exchange in the alveoli (oxygen intake, carbon dioxide release).</p> <p>d. Describes the nervous system's role in controlling breathing such as medulla oblongata.</p>	<p>Showing any 2 of these:</p> <p>a. Inhalation process is clearly explained, including the role of the diaphragm, intercostal muscles, and pressure changes.</p> <p>b. Exhalation process is accurately described, detailing how muscles relax and thoracic pressure increases.</p> <p>c. Includes a thorough explanation of gas exchange in the alveoli (oxygen intake, carbon dioxide release).</p> <p>d. Describes the nervous system's role in controlling breathing such as medulla oblongata.</p>	<p>Showing any 1 of these:</p> <p>a. Inhalation process is clearly explained, including the role of the diaphragm, intercostal muscles, and pressure changes.</p> <p>b. Exhalation process is accurately described, detailing how muscles relax and thoracic pressure increases.</p> <p>c. Includes a thorough explanation of gas exchange in the alveoli (oxygen intake, carbon dioxide release).</p> <p>d. Describes the nervous system's role in controlling breathing such as medulla oblongata.</p>

Criteria	Excellent (4 Marks)	Very Good (3 Marks)	Good (2 Marks)	Fair (1 Mark)
	e. Differentiates between voluntary and involuntary breathing with examples	e. Differentiates between voluntary and involuntary breathing with examples	e. Differentiates between voluntary and involuntary breathing with examples	e. Differentiates between voluntary and involuntary breathing with examples
Use of Relevant Real-Life Examples	<p>Showing any 4 of these:</p> <p><b>a. Examples of breathing during physical activities,</b> such as running or yoga, are included.</p> <p><b>b. Describes how altitude affects breathing and oxygen availability</b> (e.g., hiking in high-altitude areas).</p> <p><b>c. Relates to common respiratory conditions,</b> like asthma or smoking effects, impacting breathing.</p>	<p>Showing any 3 of these:</p> <p><b>a. Examples of breathing during physical activities,</b> such as running or yoga, are included.</p> <p><b>b. Describes how altitude affects breathing and oxygen availability</b> (e.g., hiking in high-altitude areas).</p> <p><b>c. Relates to common respiratory conditions,</b> like asthma or smoking effects, impacting breathing.</p>	<p>Showing any 2 of these:</p> <p><b>a. Examples of breathing during physical activities,</b> such as running or yoga, are included.</p> <p><b>b. Describes how altitude affects breathing and oxygen availability</b> (e.g., hiking in high-altitude areas).</p> <p><b>c. Relates to common respiratory conditions,</b> like asthma or smoking effects, impacting breathing.</p>	<p>Showing any 1 of these:</p> <p><b>a. Examples of breathing during physical activities,</b> such as running or yoga, are included.</p> <p><b>b. Describes how altitude affects breathing and oxygen availability</b> (e.g., hiking in high-altitude areas).</p> <p><b>c. Relates to common respiratory conditions,</b> like asthma or smoking effects, impacting breathing.</p>

Criteria	Excellent (4 Marks)	Very Good (3 Marks)	Good (2 Marks)	Fair (1 Mark)
Clarity and Precision of Explanation	<p>d. Incorporates examples of <b>deep breathing techniques</b> for stress management or meditation.</p> <p>e. Highlights <b>daily scenarios</b> where breathing changes, such as during sleep or emotional stress.</p>	<p>d. Incorporates examples of <b>deep breathing techniques</b> for stress management or meditation.</p> <p>e. Highlights <b>daily scenarios</b> where breathing changes, such as during sleep or emotional stress.</p>	<p>d. Incorporates examples of <b>deep breathing techniques</b> for stress management or meditation.</p> <p>e. Highlights <b>daily scenarios</b> where breathing changes, such as during sleep or emotional stress.</p>	<p>d. Incorporates examples of <b>deep breathing techniques</b> for stress management or meditation.</p> <p>e. Highlights <b>daily scenarios</b> where breathing changes, such as during sleep or emotional stress.</p>
	<p>Showing any 4 of these:</p> <p>a. Scientific terms such as diaphragm, alveoli, thoracic cavity) are used accurately and appropriately.</p> <p>b. Explanations of breathing mechanisms are concise and easy to understand.</p> <p>c. Diagrams or illustrations are well-labelled and enhance clarity.</p>	<p>Showing any 4 of these:</p> <p>a. Scientific terms such as diaphragm, alveoli, thoracic cavity) are used accurately and appropriately.</p> <p>b. Explanations of breathing mechanisms are concise and easy to understand.</p> <p>c. Diagrams or illustrations are well-labelled and enhance clarity.</p>	<p>Showing any 4 of these:</p> <p>a. Scientific terms such as diaphragm, alveoli, thoracic cavity) are used accurately and appropriately.</p> <p>b. Explanations of breathing mechanisms are concise and easy to understand.</p> <p>c. Diagrams or illustrations are well-labelled and enhance clarity.</p>	<p>Showing any 4 of these:</p> <p>a. Scientific terms such as diaphragm, alveoli, thoracic cavity) are used accurately and appropriately.</p> <p>b. Explanations of breathing mechanisms are concise and easy to understand.</p> <p>c. Diagrams or illustrations are well-labelled and enhance clarity.</p>

Criteria	Excellent (4 Marks)	Very Good (3 Marks)	Good (2 Marks)	Fair (1 Mark)
	<p>d. Avoids excessive jargon, making the content accessible to a general audience.</p> <p>e. Examples are integrated seamlessly into the explanation, enhancing understanding without distracting.</p>	<p>d. Avoids excessive jargon, making the content accessible to a general audience.</p> <p>e. Examples are integrated seamlessly into the explanation, enhancing understanding without distracting.</p>	<p>d. Avoids excessive jargon, making the content accessible to a general audience.</p> <p>e. Examples are integrated seamlessly into the explanation, enhancing understanding without distracting.</p>	<p>d. Avoids excessive jargon, making the content accessible to a general audience.</p> <p>e. Examples are integrated seamlessly into the explanation, enhancing understanding without distracting.</p>

## RUBRICS FOR THE PRACTICAL ASSESSMENT TASK

Criteria	Excellent (4)	Proficient (3)	Basic (2)	Needs Improvement (1)
Accuracy of Lung Structure Representation	<p>The model depicts any 4 of these Lung structures.</p> <p>a. The model includes all key components, such as the trachea, bronchi, bronchioles, alveoli, and diaphragm.</p>	<p>The model depicts any 3 of these Lung structures.</p> <p>a. The model includes all key components, such as the trachea, bronchi, bronchioles, alveoli, and diaphragm.</p>	<p>The model depicts any 2 of these Lung structures.</p> <p>a. The model includes all key components, such as the trachea, bronchi, bronchioles, alveoli, and diaphragm.</p>	<p>The model depicts any 4 of these Lung structures.</p> <p>a. The model includes all key components, such as the trachea, bronchi, bronchioles, alveoli, and diaphragm.</p>

Criteria	Excellent (4)	Proficient (3)	Basic (2)	Needs Improvement (1)
	<p>b. The proportions of the parts are realistic relative to each other.</p> <p>c. Demonstrates the functionality of the lungs, such as air movement or gas exchange (if applicable).</p> <p>d. Correct placement and connection of structures (e.g., trachea leading to bronchi).</p> <p>e. Represents the differences between the right and left lungs, such as lobes.</p>	<p>b. The proportions of the parts are realistic relative to each other.</p> <p>c. Demonstrates the functionality of the lungs, such as air movement or gas exchange (if applicable).</p> <p>d. Correct placement and connection of structures (e.g., trachea leading to bronchi).</p> <p>e. Represents the differences between the right and left lungs, such as lobes.</p>	<p>b. The proportions of the parts are realistic relative to each other.</p> <p>c. Demonstrates the functionality of the lungs, such as air movement or gas exchange (if applicable).</p> <p>d. Correct placement and connection of structures (e.g., trachea leading to bronchi).</p> <p>e. Represents the differences between the right and left lungs, such as lobes.</p>	<p>b. The proportions of the parts are realistic relative to each other.</p> <p>c. Demonstrates the functionality of the lungs, such as air movement or gas exchange (if applicable).</p> <p>d. Correct placement and connection of structures (e.g., trachea leading to bronchi).</p> <p>e. Represents the differences between the right and left lungs, such as lobes.</p>

Criteria	Excellent (4)	Proficient (3)	Basic (2)	Needs Improvement (1)
Creativity and Innovation	<p>The construction shows creativity and organisation of any 4 of these:</p> <ol style="list-style-type: none"> <li>Unique use of materials to construct the model, such as balloons for alveoli and straws for bronchi).</li> <li>It incorporates interactive features, such as inflating balloons, to simulate breathing.</li> <li>Aesthetic appeal of the model, using colour and design to enhance understanding.</li> <li>Creative representation of less visible structures such as capillaries around alveoli.</li> </ol>	<p>The construction shows creativity and organisation of any 3 of these:</p> <ol style="list-style-type: none"> <li>Unique use of materials to construct the model, such as balloons for alveoli and straws for bronchi).</li> <li>It incorporates interactive features, such as inflating balloons, to simulate breathing.</li> <li>Aesthetic appeal of the model, using colour and design to enhance understanding.</li> <li>Creative representation of less visible structures such as capillaries around alveoli.</li> </ol>	<p>The construction shows creativity and organisation of any 2 of these:</p> <ol style="list-style-type: none"> <li>Unique use of materials to construct the model, such as balloons for alveoli and straws for bronchi).</li> <li>It incorporates interactive features, such as inflating balloons, to simulate breathing.</li> <li>Aesthetic appeal of the model, using colour and design to enhance understanding.</li> <li>Creative representation of less visible structures such as capillaries around alveoli.</li> </ol>	<p>The construction shows creativity and organisation of any 1 of these:</p> <ol style="list-style-type: none"> <li>Unique use of materials to construct the model, such as balloons for alveoli and straws for bronchi).</li> <li>It incorporates interactive features, such as inflating balloons, to simulate breathing.</li> <li>Aesthetic appeal of the model, using colour and design to enhance understanding.</li> <li>Creative representation of less visible structures such as capillaries around alveoli.</li> </ol>

Criteria	Excellent (4)	Proficient (3)	Basic (2)	Needs Improvement (1)
Functionality and Demonstration	<p>e. Inclusion of additional elements, like labels or diagrams, to enhance learning.</p> <p>The model shows the Functionality of any 4 of these:</p> <p>a. The model effectively demonstrates the breathing process (inhalation and exhalation).</p> <p>b. Airflow is visible or can be simulated using the model.</p> <p>c. Demonstrates how the diaphragm movement influences lung expansion and contraction.</p> <p>d. Interactive elements work as intended such as balloons inflate smoothly.</p>	<p>e. Inclusion of additional elements, like labels or diagrams, to enhance learning.</p> <p>The model shows the Functionality of any 3 of these:</p> <p>a. The model effectively demonstrates the breathing process (inhalation and exhalation).</p> <p>b. Airflow is visible or can be simulated using the model.</p> <p>c. Demonstrates how the diaphragm movement influences lung expansion and contraction.</p> <p>d. Interactive elements work as intended such as balloons inflate smoothly.</p>	<p>e. Inclusion of additional elements, like labels or diagrams, to enhance learning.</p> <p>The model shows the Functionality of any 2 of these:</p> <p>a. The model effectively demonstrates the breathing process (inhalation and exhalation).</p> <p>b. Airflow is visible or can be simulated using the model.</p> <p>c. Demonstrates how the diaphragm movement influences lung expansion and contraction.</p> <p>d. Interactive elements work as intended such as balloons inflate smoothly.</p>	<p>e. Inclusion of additional elements, like labels or diagrams, to enhance learning.</p> <p>The model shows the Functionality of any 1 of these:</p> <p>a. The model effectively demonstrates the breathing process (inhalation and exhalation).</p> <p>b. Airflow is visible or can be simulated using the model.</p> <p>c. Demonstrates how the diaphragm movement influences lung expansion and contraction.</p> <p>d. Interactive elements work as intended such as balloons inflate smoothly.</p>

Criteria	Excellent (4)	Proficient (3)	Basic (2)	Needs Improvement (1)
Neatness and Durability of the Model	<p>e. Model can be used to explain the concept of gas exchange in the alveoli.</p> <p>The model depicts any 4 these:</p> <p>a. Neat and clean presentation, avoiding messy glue or tape application.</p> <p>b. Durable materials are used to ensure the model can withstand handling.</p> <p>c. Labels are clear and readable, aiding in understanding the parts of the lungs.</p> <p>d. Overall, the structure is stable and does not collapse or fall apart during the demonstration.</p>	<p>e. Model can be used to explain the concept of gas exchange in the alveoli.</p> <p>The model depicts any 3 these:</p> <p>a. Neat and clean presentation, avoiding messy glue or tape application.</p> <p>b. Durable materials are used to ensure the model can withstand handling.</p> <p>c. Labels are clear and readable, aiding in understanding the parts of the lungs.</p> <p>d. Overall, the structure is stable and does not collapse or fall apart during the demonstration.</p>	<p>e. Model can be used to explain the concept of gas exchange in the alveoli.</p> <p>The model depicts any 2 these:</p> <p>a. Neat and clean presentation, avoiding messy glue or tape application.</p> <p>b. Durable materials are used to ensure the model can withstand handling.</p> <p>c. Labels are clear and readable, aiding in understanding the parts of the lungs.</p> <p>d. Overall, the structure is stable and does not collapse or fall apart during the demonstration.</p>	<p>e. Model can be used to explain the concept of gas exchange in the alveoli.</p> <p>The model depicts any 1 these:</p> <p>a. Neat and clean presentation, avoiding messy glue or tape application.</p> <p>b. Durable materials are used to ensure the model can withstand handling.</p> <p>c. Labels are clear and readable, aiding in understanding the parts of the lungs.</p> <p>d. Overall, the structure is stable and does not collapse or fall apart during the demonstration.</p>



## APPENDIX D: END OF SEMESTER EXAMINATION

### The nature of the end of semester examination

The end of semester examination will cover weeks 13- 24 and consist of three papers: 1, 2, and 3. Paper 1 consists of 50 objective tests, paper 2 consists of five essay types, three of which will be selected, and paper 3 consists of four compulsory practical tests, all which learners are to answer.

### Resource

Printer, A4 sheets, answer booklets, stationery, timers; for e-Assessment, consider a stable internet connection, computer, tablet, etc.

**Duration:** 120 minutes

### Sample task

**Paper 1:** This section consists of 50 objective test items. Answer all questions. Each question carries 1 mark, for a total score of 50 marks.

Match the following lung structures to their correct descriptions:

lung structures	Description
1. Alveoli	a) Membrane that reduces friction description between the lungs and chest wall
2. Bronchi	b) tiny air sacs where gas exchange occurs
3. Pleura	c) Muscle that assists in breathing by changing thoracic volume
4. Diaphragm	d) small airways that lead directly to the alveoli
5. Bronchioles	e) large tubes that branch off the trachea into each lung

**Paper 2:** This paper consists of five (5) questions, answer only three (3). Each question carries fifteen (15) marks making the total score 45 marks.

Describe the processes involved in excretion by the large intestine.

**Paper 3:** This paper consists of two (2) compulsory tests of practical questions, all of which must be answered for a total of forty (40) marks.

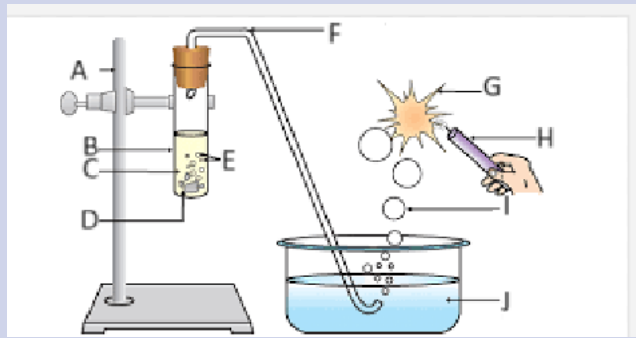

- Write the chemical formula for the model
- Write word formula for the model
- Label the part A- I

### Scoring criteria /rubrics

#### Paper 1: Objective test

Answer to sample objective question = Alveoli---Tiny air sacs where gas exchange occurs

Award 1 mark for each correct objective answer

#### Paper 2: Essay

- Identification of processes such as Formation of Faeces, Absorption of Water and Electrolytes, etc. (1marks for each point = 3marks)
- A clear explanation with examples, such as the absorption of water and electrolytes, is that after the small intestine has absorbed most of the nutrients from digested food, the remaining material enters the large intestine (4 marks)
- A clear explanation without examples, such as the absorption of water and electrolytes, is that after the small intestine has absorbed most of the nutrients from digested food, the remaining material enters the large intestine. (2 marks)
- A clear example without explanation, such as the absorption of water and digested food (1 mark)

#### Paper 3: Test o practical

Correct chemical formula of the model such as

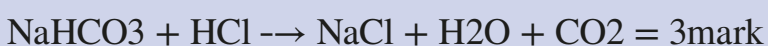

Correct word formula of the model such as Metal carbonate/metal Hydrogen carbonate + Acid  $\rightarrow$  Salt + water + carbon dioxide = 3marks

NB: formula without arrow = 1 mark

**Table of Specifications for Week 1-12**

Weeks	Focal Area(s)	Type of Questions	DoK Levels				Total
			1	2	3	4	
1	Acids, Alkalis/Bases and Water	Objective test				-	1
		Essay	1	-	1	-	2
		Test of Practical		-		-	-
2	Application of acid and bases in salt formation	Objective test		3		-	3
		Essay	1	-	1	-	2
		Test of Practical					
3	pH measurement	Objective test		1	1	-	2
		Essay	1	1	-	-	2
		Test of Practical		1			1
4	Using the pH Scale to Identify the Concentration of Acids and Bases/Alkalis solution	Objective test		1	1	-	2
		Essay	1	-	1	-	2
		Test of Practical	1				1
5	Understanding the Structure and Function of Human Excretory Organs	Objective test		1	1	1	3
		Essay	1	-	-	-	1
		Practical	1	1	-	-	2
6	Analyse the structure and function of the excretory organs in the human body	Objective test		-	-	1	1
		Essay	1	1			2
		Test of Practical	1				1
7	Describe the processes for the removal of waste from the human body.	Objective test		3	1		4
		Essay					
		Test of Practical	1	1			2
8	Describe the processes for the removal of waste from the human body.	Objective test		1			1
		Essay	1				1
		Test of Practical					

Weeks	Focal Area(s)	Type of Questions	DoK Levels				Total
			1	2	3	4	
9	Describe the processes for the removal of waste from the human body.	Objective test	1	2	1	1	55
		Essay					
		Test of Practical	1				
10	Explain, with diagrams, the concept of the movement of air in humans and its importance	Objective test		1	1	1	3
		Essay	1				1
		Test of Practical	1				1
11	Describe the structure of the lungs and investigate the products of aerobic respiration	Objective test		1		1	2
		Essay			1		1
		Test of Practical		1			1
		Total	15	20	10	5	50

# SECTION 4: CONCEPTS OF ELECTRICITY

## Strand: Vigour behind life

### Sub-strand: Powering the future with energy forms

**Learning outcome:** Construct and analyse electric circuits in determining resistance, potential difference, and current and distinguish between step-up and step-down transformers

**Content standard:** Demonstrate understanding of electricity as a form of energy

#### Hint



Assign learners individual project in week 13 on producing a named local indigenous beverage in their hometown to be submitted week 21. Refer to Appendix E at the end of this section for more information on the project.

## INTRODUCTION AND SECTION SUMMARY

This section focuses on electrical energy and power, which are fundamental to understanding how electricity is generated, transferred, and utilised. Electrical energy, measured in joules or watt-hours, results from the movement of electric charge, while electrical power, measured in watts, indicates the rate at which this energy is transferred.

The weeks covered by the section are:

Week 13: *Explain the concept of electrical energy and power.*

Week 14: *Explain the concept of electrical energy and power*

Week 15: *Explain the principle of the transformer and its function.*

## SUMMARY OF PEDAGOGICAL EXEMPLARS

In this section various pedagogical approaches are utilised to teach electrical concepts, incorporating cross-cutting issues like Gender Equality and Social Inclusion (GESI) and Social and Emotional Learning (SEL). Collaborative learning involves mixed-ability groups using PHET simulations, analysing energy sources, and building circuits. Activity-based learning has learners measuring electrical quantities and analysing energy usage. Problem-based learning presents real-life troubleshooting scenarios, while project-based learning involves designing electrochemical cells. Experiential learning

includes hands-on experiments and building transformer models. Talk-for-learning sessions discuss theoretical concepts and encourage group presentations. Field trips connect theoretical knowledge with practical applications, promoting 21st-century skills and national core values. Scaffolding support and role assignments, such as group leader and secretary, ensure inclusive and effective learning experiences.

## **ASSESSMENT SUMMARY**

Assessment in this pedagogical approach focuses on both individual and group performance, incorporating a variety of methods to ensure comprehensive evaluation. Learners are assessed through practical lab activities, projects, and real-life problem-solving scenarios. Group tasks such as analysing energy sources and building circuits are evaluated based on collaboration and the accuracy of findings. Written reports, charts, and presentations on experiments and energy audits measure understanding and communication skills. Peer reviews and discussions enhance critical thinking and feedback mechanisms. Role assignments and scaffolded support are assessed to ensure inclusivity and equal participation, promoting 21st-century skills and national core values while addressing cross-cutting issues like GESI and SEL.

Teachers can consult the Teacher Assessment Manual and Toolkits (TAMT) (NaCCA, MoE, 2003) for guidance on effectively utilising various assessment strategies.

## WEEK 13

**Learning Indicator:** Explain the concept of electrical energy and power

### FOCAL AREA: THE CONCEPT OF ELECTRICAL ENERGY AND POWER

#### Overview of electrical energy

Electricity is a transfer of energy resulting from the presence and flow of electric charges, commonly harnessed for countless applications in modern life. It involves the movement of electrons (or ions) through conductors, creating an electric current measured in Amperes.





Voltage, or electric potential difference, drives this current, pushing charges through circuits composed of various components like resistors and capacitors.





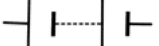

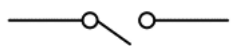

Electricity is generated from diverse sources, including fossil fuels, nuclear power, and renewables. It is transmitted over long distances to be used in homes, businesses, and industries. While immensely useful, electricity requires careful handling and safety measures to prevent hazards like electric shocks and fires.

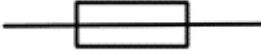
#### Components of an electrical circuit

An electrical circuit consists of various components that work together to control and direct the flow of electric current (flow of electrons) in the way desired by the user.

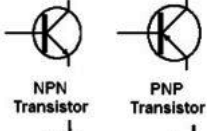
**Table 13.1:** Components of electrical circuit, their function and their circuit symbol

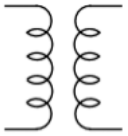
Basic component	Function	Circuit symbol
Battery	Provides direct current (DC) through a chemical reaction.	
Power supply	Converts AC from the mains to a stable DC voltage.	
Connecting wire	Provides a path for current to flow between components.	
Light bulb (two accepted symbols)	Converts electricity into light.	
Switch	For opening or closing a circuit, controlling the current flow.	

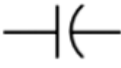
Basic component	Function	Circuit symbol
Fuse	Provide overcurrent protection by breaking the circuit if the current exceeds a certain level. The protects the circuit from high voltages.	
Resistor (two accepted symbols)	Controls current flow and distribute voltage.	
Inductor	Stores energy in a magnetic field when current flows through them.	
Diode	Allows current to flow in one direction only.	
Transistor	Acts as a switch or amplifier.	
Ammeter	Measures current flowing a circuit	
Voltmeter	Measures voltage/potential differences in a circuit	
Transformer	Changes the voltage level in AC circuits.	
Light emitting diode	Indicates presence of current flow in a circuit	
Capacitor	Stores electrical charges	

## Batteries

### *Making of electrical cells*

Electrical cells, commonly known as batteries, store chemical energy and allow it to be transferred to other energy stores via electricity. The cell is the fundamental unit of the battery.

They make use of the energy stored within chemical bonds and are essential for powering a wide range of electronic devices. A simple cell consists of two electrodes in a container holding the electrolyte. In some cells, the container acts as one of the electrodes and, in this case, is acted upon by the electrolyte.

### EXPERIMENT 13.1 – Making a simple zinc-carbon cell

**Aim:** Demonstrate how to make simple zinc-carbon cell

**Apparatus:** Zinc strip (anode), carbon rod (cathode), manganese dioxide and carbon powder mixture (cathode paste), ammonium chloride solution (electrolyte), paper or cloth separator, plastic or metal container.

#### Procedure

1. Place the zinc strip into the container at the bottom (anode).
2. Pour the ammonium chloride solution into the container to submerge the zinc strip.
3. Insert the paper or cloth separator to cover the zinc strip.
4. Apply the cathode paste (manganese dioxide and carbon powder mixture) around the carbon rod.
5. Place the carbon rod with the cathode paste into the container, ensuring the separator separates it from the zinc strip.
6. Seal the container to prevent leakage.
7. Attach metal strips to the zinc strip and carbon rod to create external connections.
8. Connect this battery using crocodile clips to an LED (ensuring correct polarity).
9. Observe if the battery is working and lighting up the LED. (NB this may require multiple batteries in series).

#### Safety Precautions

1. Chemical handling: Always handle chemicals with care, using gloves and protective eyewear.
2. Conduct this experiment within a plastic tray to contain any spills.

3. Ventilation: Work in a well-ventilated area to avoid inhaling fumes.
4. Disposal: Properly dispose of chemical waste according to local regulations.

## EXPERIMENT 13.2 - Making batteries from fruits and vegetables

**Aim:** To demonstrate that fruits and vegetables can be used as batteries

**Apparatus:** Alligator Clips (twelve small sizes), LED (one), pennies (ten), galvanized nails (twelve), lemons (ten) or potatoes.

### Procedure

#### Creating a lemon battery

A

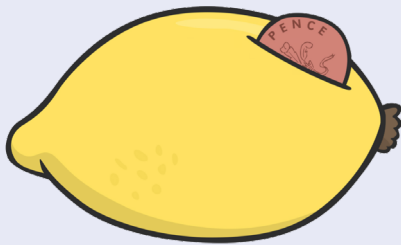

**Step 1:** Insert a coin into the side of the lemon.

B

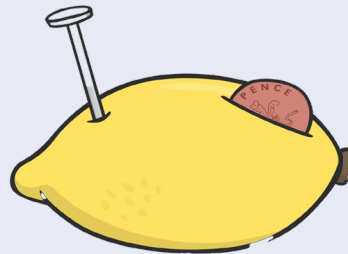

**Step 2:** Push one of the nails into the other side of the lemon. Make sure that the coin and nail do **not** touch.

C

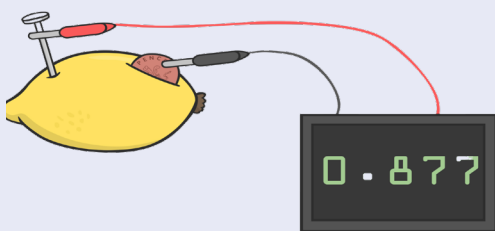

**Step 3:** You can check that the lemon battery cell is producing a voltage by connecting a voltmeter to the electrodes.

D

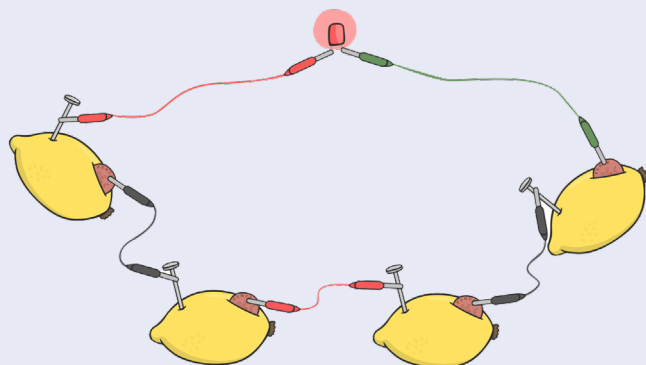

**Step 4:** To power a small bulb you will need to create more battery cells and connect them together. This will create a high voltage.

**Fig. 13.1a, b, c, d:** Diagram showing creating a lemon battery

## Construction of functional electrical circuit

Constructing a functional electrical circuit involves several key steps, from planning and gathering materials to assembly and testing.

### *Step 1: Planning and design*

- a) **Define purpose:** Determine the goal of your circuit (e.g., lighting an LED, powering a motor).
- b) **Create a schematic:** Draw a circuit diagram showing all components and their connections.
- c) **Components needed:** List all necessary components (resistors, capacitors, power source, etc.).
- d) **Values and ratings:** Specify the values (e.g., resistor values in Ohms) and ratings (e.g., voltage and current) for each component.

### *Step 2: Gather materials and tools*

**Materials:** Power source (battery or power supply), conductors (wires), load (LED, motor, etc.), control devices (switches), protective devices (resistors, fuses), breadboard or PCB (for assembly), multimeter (for testing), wire strippers, soldering iron and solder (if using PCB), pliers and screwdrivers, insulating tape or heat shrink tubing.

### *Step 3: Prepare the components*

**Check Components:** Verify that all components are working and rated for your circuit.

**Trim Wires:** Cut wires to the necessary lengths and strip the ends for connections.

### *Step 4: Build the circuit*

**Using a breadboard:** Place components on the breadboard according to your schematic. Jumper wires are used to connect components as per the circuit diagram.

Ensure all connections match your schematic.

#### Using a PCB

Use software or a pre-made design for the PCB layout.

Create the PCB if you're making it yourself or order it from a manufacturer.

Insert components into the PCB holes.

Solder each component led to the PCB pads, ensuring solid electrical connections.

**Inspect solder joints:** Check for cold solder joints or bridges that could cause shorts.

### *Step 5: Testing*

Check for correct placement and secure connections.

Power the circuit with a lower voltage (if possible) to check for obvious issues.

A multimeter measures voltages and currents at different points in the circuit.

If the circuit doesn't work, recheck connections and component orientations. Look for shorts or open circuits.

### *Step 6: Final assembly and safety*

Ensure all components are securely mounted.

Use insulating tape or heat shrink tubing to cover exposed wires and prevent shorts.

If the circuit will be used in a specific environment, consider placing it in an enclosure to protect it.

## EXPERIMENT 13.3 – Experiment to constructing a simple LED circuit

**Aim:** Understand how to connect components to create a functional circuit

**Apparatus:** 9V Battery, LED (any colour), resistor (330  $\Omega$ , suitable for a 9V battery and standard LED), breadboard, connecting wires, multimeter (for testing), battery clip (for connecting the 9V battery to the breadboard), wire strippers, pliers (optional)

### Safety Precautions

1. Ensure all connections are secure before powering the circuit.
2. Do not touch live wires or components with bare hands.
3. Disconnect power before making adjustments to the circuit.

### Procedure

1. The schematic for a simple LED circuit includes the following components connected in series: a 9V battery, a 330  $\Omega$  resistor, and an LED.
2. Check components: Ensure the LED, resistor, and battery are in good condition. If necessary, cut and strip the ends of connecting wires.
3. Place the resistor: Insert the 330  $\Omega$  resistor into two adjacent rows on the breadboard. Place the LED's anode (longer lead) into the same row as one end of the resistor. Insert the cathode (shorter lead) into a separate row.
4. Connect the 9V battery to the breadboard using a battery clip. Connect the positive terminal of the battery clip to the row with the free end of the resistor and connect the negative terminal of the battery clip to the row with the cathode of the LED. Ensure all connections are correct and secure.
5. Connect the 9V battery to the battery clip. The LED should light up, indicating a functional circuit.

- Use a multimeter to measure the voltage drop across the LED and resistor. Measure the current flowing through the circuit.

**Observation:** The LED should emit light when the circuit is powered. If it doesn't, recheck connections and component orientations. Ensure all components are firmly placed and connections are secure.

## Calculation of current, resistance and voltage

### Electric current

A net movement or flow of charge in one direction constitutes an electric current. The charge carriers in a conducting metal are free electrons originating from the tightly linked metal atoms that make up the conductor's structure. Since their outer electrons are only loosely bound to the atom, many can break free and circulate freely throughout the metal's structure. The metal atoms are now positively charged instead of neutral since they have lost electrons. Two of the best metallic conductors are copper and silver.

**Current** is the rate of flow of charge. If the current is constant, we can use the equation:

$$Q = It$$

$I$  = current (Amps, A),  $Q$  = charge flowing past a point (Coulombs, C),  $t$  = time taken for charge  $Q$  to flow (seconds, s).

This formula will also give the average current if the current is variable. If the current is not constant, then the gradient of a charge (y-axis) against the time (x-axis) graph will give the current at a particular time.

### Voltage

Voltage measures how much potential energy a unit charge has at a point, specifically in an electric circuit. Voltage is always measured as a difference with respect to an arbitrary common point called ground. Voltage is also known as electromotive force or emf (electromotive force) outside engineering.

Potential difference exists between two points if a charge has a differing value of potential energy at each point. A voltage drop means the charge has lost energy; an emf means the charge has been supplied with energy.

$$E = VQ$$

$E$  = Energy transferred (Joules, J)  $Q$  = charge flowing past a point (Coulombs, C),  $V$  = potential difference/voltage (Volts, V).

### Resistance

Ohm's Law states that, at constant temperature, the electric current flowing in a conducting material is directly proportional to the applied voltage and inversely proportional to the

resistance. It can be shown that the current flowing through a wire composed of a substance is proportional to the potential difference across its ends for a wide variety of substances:  $I \propto V$ .

The way we write this relation is as follows:

$$R = \frac{V}{I} \text{ or } V = IR$$

where  $R$  (the resistance of the component) is a constant that varies according to the wire's characteristics (material and dimensions).

From the relation  $R = \frac{V}{I}$  we see that the units of resistance must be  $VA^{-1}$ . This combination of units is called an Ohm:

$$1 \text{ ohm} = 1\Omega = 1\frac{V}{A}$$

Where;

$V$  is the voltage in Volts (V),

$I$  is the current in Amperes (A), and

$R$  is the resistance in Ohms ( $\Omega$ ).

### Worked examples

1. What is the voltage if a component with a resistance of $25 \Omega$ has a current of 250 amperes flowing through it?	2. What is the current produced by a voltage of 240 V through a resistance of $0.2 \Omega$ ?	3. What voltage is necessary to produce a current of 200 amperes through a resistance of $100 \Omega$ ?	4. What resistance would produce a current of 120 amps from a 6-V battery?
$V = I \times R$ $V = (250)(25)$ $V = 6,250 \text{ Volts}$	$I = V \div R$ $I = (240) \div (0.2)$ $I = 1,200 \text{ Amps}$	$V = I \times R$ $V = (200)(100)$ $V = 20,000 \text{ Volts}$	$R = V \div I$ $R = (6) \div (120)$ $R = 0.05 \text{ Ohms}$ $(\Omega)$

## Series and parallel connections

Most circuits have more than one device that receives electricity. These devices are commonly connected in a circuit in one of two ways: series or parallel.

## Series

Electrical components in a circuit can be connected in series to create a single path for current flow. Every component in a series connection is linked end to end in a line. When the switch is closed, a current exists almost immediately in both lamps. The current does not “pile up” in any lamp but flows through each lamp. Electrons in all parts of the circuit begin to move at once. A break anywhere in the path results in an open circuit, and the flow of electrons ceases. Burning out of one of the lamp filaments or simply opening the switch could cause such a break.

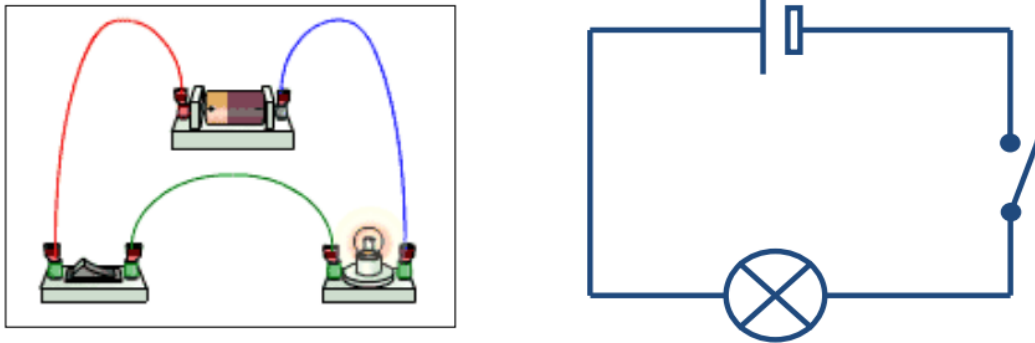

**Fig. 13.1:** A simple series circuit

### Characteristics

1. **Single path:** Components are connected end-to-end, providing only one current path.
2. **Current:** The same current flows through all components.
3. **Voltage:** The total voltage (provided by the power source) is the sum of the voltages across each load component.
4. **Resistance:** The total resistance is the sum of the individual resistances.

To save time in drawing circuits, we will need to use schematic diagrams (as shown in Figure 13.3). The symbols for each component can be found in the table at the beginning of this section. In any of these circuits, the precise shapes of the wires that connect the elements matter; we only need to care about the circuit elements and how they are connected to the other elements.



**Fig.13.2:** diagram of electric circuit **Fig.13.3:** diagram of a schematic electric circuit

The first kind of circuit we consider is where a battery is connected to two or more resistors joined end-to-end. In this circuit, the same current  $I$  flow through  $R_1$  and  $R_2$  (it has nowhere else to go).

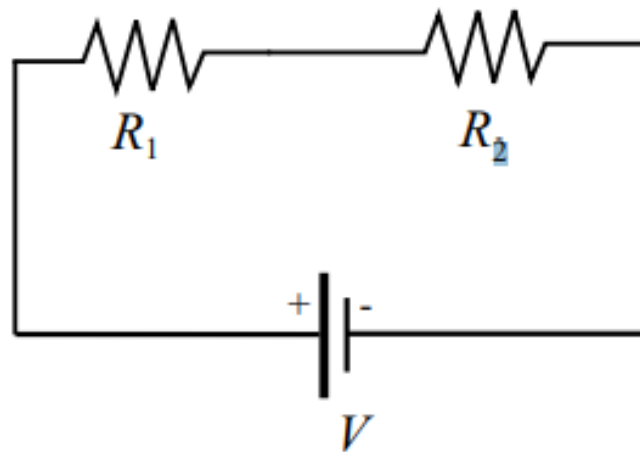

**Fig. 13.4:** Diagram of resistors in series

## Resistance in a series circuit

According to Ohm's law, the drops in potential across the two resistors are  $IR_1$  and  $IR_2$ . The sum of these potential drops must equal  $V$ , the gain in potential across the battery.

So then:  $IR_1 + IR_2 = V \implies V = I(R_1 + R_2) = IR_T$  where the equivalent resistance of the pair is the sum,  $R_1 + R_2$ .

We have found that when we have a few resistors in series, we can replace them with the equivalent resistance given by:

$$R_T = R_1 + R_2 + R_3 + \dots$$

## Current in a series circuit

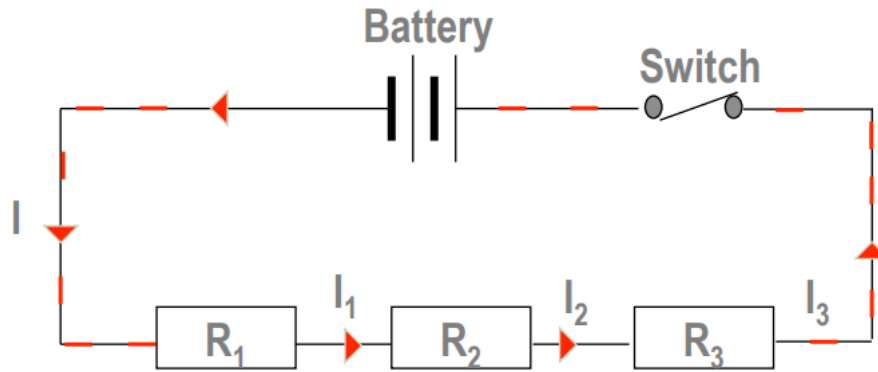

**Fig. 18:** Diagram of current in a series circuit.

The current is the same everywhere due to Kirchoff's First Law;  $I=I_1=I_2=I_3$ .

To find the current of a series circuit you must know the TOTAL voltage and the TOTAL resistance of the circuit ( $R_T$ ).

$$I_{\text{Total}} = \frac{V_{\text{Total}}}{R_T}$$

## Voltage in a Series Circuit

The total voltage “around” the circuit is equal to the voltage drop across each component:

$$V_T = V_1 + V_2 + V_3 + \dots$$

### Worked examples

1. What is the total resistance of the following circuit?

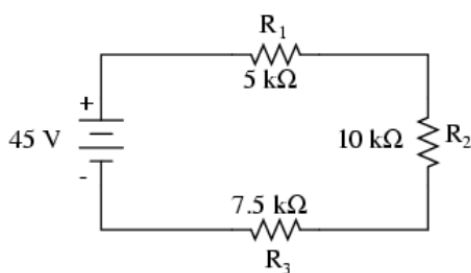

$$\begin{aligned} R_{(\text{equiv})} &= R_1 + R_2 + R_3 \\ &= 5k + 10k + 7.5k \\ &= 22.5 \text{ k}\Omega \end{aligned}$$

2. Calculate the total resistance  $2\Omega$

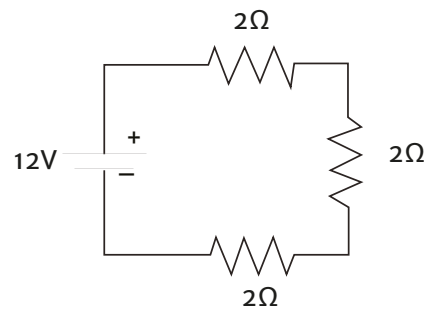

$$\begin{aligned} R_T &= R_1 + R_2 + R_3 \text{ } 2\Omega \\ R_T &= 2 + 2 + 2 \\ R_T &= 6\Omega \end{aligned}$$

3. In a series circuit with resistors of  $8\Omega$  and  $12\Omega$ , and a voltage supply of  $40V$ , calculate the voltage drop across each resistor.

$$R_{\text{Total}} = 8 + 12 = 20 \Omega$$

*Current:*

$$I = V/R$$

$$I = 40/20$$

$$I = 2A$$

*Voltage drop across  $8\Omega$  resistor:*

$$V = I \times R$$

$$V = 2 \times 8$$

$$V = 16V$$

*Voltage drop across  $12\Omega$  resistor:*

$$V = I \times R$$

$$V = 2 \times 12$$

$$V = 24V$$

4. A series circuit has two resistors,  $10\Omega$  and  $20\Omega$ , connected to a  $60V$  power supply. Calculate the current through the circuit.

*Total resistance:*

$$R\{\text{total}\} = 10 + 20 = 30 \Omega$$

*Current:*

$$I = \frac{V}{R}$$

$$I = \frac{60}{30}$$

$$I = 2A$$

## Parallel circuits

A parallel circuit is a way of connecting electrical components in a circuit so that they form multiple paths for current flow. In a parallel circuits, all components are connected “across” each other’.

### Characteristics

- Multiple paths:** Components are connected across common points or junctions, providing multiple paths for current to flow.
- Current:** The total current is the sum of the currents through each parallel branch. Kirchoff’s First Law.
- Voltage:** The voltage across each branch is the same.
- Resistance:** The total resistance is less than the smallest branch resistance.

## Resistors in a parallel circuit

Total resistance is given by the formula:

$$\frac{1}{R_T} = \frac{1}{R_1} + \frac{1}{R_2} + \frac{1}{R_3} + \dots$$

### Worked examples

**Q1.** Use the diagram below to answer the question.

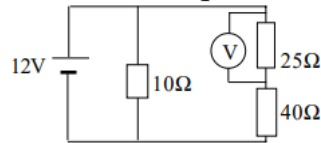

Given the voltmeter shown in the above diagram can be taken to have an infinite resistance

Find

- the total resistance of the circuit.
- the current drawn from the cell.
- the reading on the voltmeter.

### Solution

**a)** First, work out a series combination, then combine with  $10\Omega$  resistance.

Work in this order as the  $10\Omega$  is in parallel with both  $25\Omega$  and  $40\Omega$ .

$$\text{Total resistance} = R_1 + R_2 = 25 + 40 = 65\Omega$$

Parallel combination:

$$\frac{1}{R_T} = \frac{1}{R_1} + \frac{1}{R_2}, R_1 = 10\Omega, R_2 = 65\Omega$$

$$R_T = \frac{R_1 \times R_2}{R_2 + R_1} = \frac{10 \times 65}{65 + 10} = 8.7\Omega$$

**b)** The total current is the voltage supply divided by the total resistance:

$$I = \frac{V}{R} = \frac{12}{8.7} = 1.38\text{A}$$

**c)** The current through the final branch of the circuit is:

$$I = \frac{V}{R} = \frac{12}{65} = 0.18\text{A}$$

Now we have the current through the  $25\Omega$  resistor and use its resistance.

$$V = IR$$

$$= 0.18 \times 25$$

$$= 4.5\text{V}$$

**Q2.** Use the diagram below to answer the question.

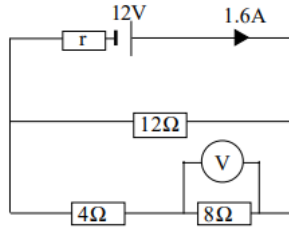

(i) What is the total resistance of the circuit now?

### Solution

Resistors in series

$$R_T = R_1 + R_2,$$

where  $R_1 = 4\Omega$ ,  $R_2 = 8.0\Omega$

$$R_T = 4 + 8 = 12\Omega$$

In parallel connection with  $12\Omega$  resistor

$$= \frac{1}{R_T} = \frac{1}{R_1} + \frac{1}{R_2}, \text{ where } R_1 = 12.0\Omega, R_2 = 12.0\Omega$$

$$R_T = \frac{R_1 \times R_2}{R_2 + R_1} = \frac{12 \times 12}{12 + 12} = 6.0\Omega$$

**Q3** Determine the equivalent (total) resistance for each of the following circuits below.

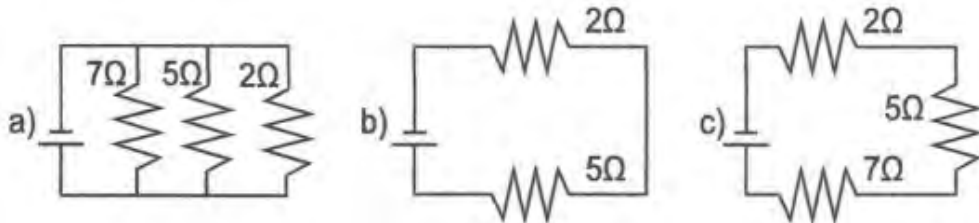

$$\begin{aligned} \text{a. } \frac{1}{R_T} &= \frac{1}{R_1} + \frac{1}{R_2} + \frac{1}{R_3} \\ &= \frac{1}{R_T} = \frac{1}{7} + \frac{1}{5} + \frac{1}{2} = \frac{59}{70} \end{aligned}$$

$$\frac{1}{R_T} = \frac{59}{70}$$

$$R_T = \frac{70}{59} = 1.2\Omega$$

$$\text{b. } R = R_1 + R_2$$

$$R = 2 + 5$$

$$R = 7\Omega$$

$$\begin{aligned} \text{c. } R &= R_1 + R_2 + R_3 \\ R &= 2 + 5 + 7 \\ R &= 14\Omega \end{aligned}$$

## EXPERIMENT 13.4 - Parallel arrangement of resistors in electrical circuit

**Aim:** To show parallel arrangement of resistors in electrical circuit.

**Apparatus:** Breadboard, resistors, wires, and a multimeter.

### Procedures:

1. Connect resistors in parallel on a breadboard.
2. Measure the voltage across each resistor to confirm they are the same.
3. Measure the total current by placing the ammeter in series with the power source and the current through each resistor by placing the ammeter in series with each resistor in turn.
4. Calculate the equivalent resistance and compare it with the measured values.

## Power

**Power** is the rate at which work is done or energy is transferred over time. It is a measure of how quickly energy is used or produced. The standard power unit is the Watt (W), equivalent to one Joule per second (J/s).

The formula for power is:

$$\text{Power} = \frac{\text{Work done}}{\text{Time taken}}$$

Or, in terms of energy:

$$\text{Power} = \frac{\text{Energy transferred}}{\text{Time taken}}$$

In symbols:

$$P = \frac{W}{t}$$

where:

- P is power (Watts, W)
- W is work done, or energy transferred (Joules, J)
- t is time (seconds, s)

## Examples

If power rating of an incandescent light bulb is 60 Watts (W) and the bulb is used for 5 hours a day, its total energy used per day is:

$$60 \text{ W} * 5 \text{ hours} = 300 \text{ Watt-hours (Wh)}$$

$$\text{or } 60 \text{ W} * (5 \times 60 \times 60) \text{ s} = 1,080,000 \text{ Joules (J)}$$

## Electrical Power

In electrical circuits, power is the rate at which electrical energy is consumed or produced by a component, such as a resistor, motor, or generator. The formula for electrical power is:

$$P = V \times I$$

where:

- P is power (in Watts, W)
- V is voltage (in Volts, V)
- I is current (in Amperes, A)

For resistive loads, the power can also be expressed by combining the formula above with Ohm's Law ( $V = I \times R$ )

$$P = I^2 \times R$$

$$P = V^2 / R$$

## Appliance troubleshooting

**Appliance troubleshooting** is the systematic approach of diagnosing problems in household appliances and finding solutions to fix them. This can involve inspecting the appliance for obvious issues, performing tests, and following steps to identify and resolve the malfunction.

Troubleshooting household appliances can help identify and resolve common issues without professional assistance.

### *Components of appliance troubleshooting*

1. **Observation:** Look for visible signs of damage, wear and tear, or anything unusual (e.g., frayed wires, broken parts, leaks).
2. **Power check:** Ensure the appliance receives power by checking the power cord, plug, and outlet. Test the outlet with another device to confirm it's working.
3. **Reset and restart:** Some appliances have a reset button. Turning the appliance off and on or using the reset function can sometimes resolve minor issues.

4. **Consult the manual:** The appliance's user manual often contains troubleshooting tips and solutions for common problems specific to the model.
5. **Basic tests:** Perform basic tests to check the functionality of the appliance's components. This can include testing switches, fuses, and other easily accessible parts.
6. **Sound and smell:** Pay attention to unusual sounds or smells which can indicate specific issues (e.g., a burning smell could indicate an electrical problem).
7. **Error codes:** Modern appliances often display error codes when something goes wrong. Refer to the manual to understand the error code and follow the recommended steps to address it.

### *Steps in troubleshooting common appliances*

**Table 13.2:** *The table shows common issues of household appliances and their troubleshooting steps*

Common issues Of Household appliances	Troubleshooting Steps
<b>Refrigerator</b>	<p><b>Not cooling</b></p> <ol style="list-style-type: none"> <li>1. Check temperature settings.</li> <li>2. Clean condenser coils.</li> <li>3. Ensure door seals are intact.</li> <li>4. Verify vents inside the fridge are not blocked.</li> <li>5. Check the drain pan and water supply line for leaks.</li> </ol> <p><b>Leaking water</b></p> <ol style="list-style-type: none"> <li>1. Check the drain pan for overflow.</li> <li>2. Inspect the water supply line for leaks.</li> <li>3. Clear any clogs in the defrost drain.</li> </ol> <p><b>Unusual noises</b></p> <ol style="list-style-type: none"> <li>1. Ensure the refrigerator is level.</li> <li>2. Check for loose components inside the fridge or freezer.</li> </ol>

Common issues Of Household appliances	Troubleshooting Steps
<b>Washing machine</b>	<p><b>Not draining</b></p> <ol style="list-style-type: none"> <li>1. Check the drain hose for kinks or clogs.</li> <li>2. Clean the drain pump filter.</li> <li>3. Inspect the lid switch or door lock mechanism.</li> </ol> <p><b>Not spinning</b></p> <ol style="list-style-type: none"> <li>1. Ensure the load is balanced.</li> <li>2. Check the drive belt for wear or damage.</li> <li>3. Inspect the motor coupling and lid switch.</li> </ol> <p><b>Leaking water</b></p> <ol style="list-style-type: none"> <li>1. Inspect the water inlet hoses and connections.</li> <li>2. Check the door seal for damage.</li> <li>3. Ensure the detergent drawer is not clogged.</li> </ol>
<b>Dishwasher</b>	<p><b>Not cleaning dishes</b></p> <ol style="list-style-type: none"> <li>1. Check and clean the spray arms.</li> <li>2. Ensure the detergent dispenser is working.</li> <li>3. Clean the filter and drain.</li> </ol> <p><b>Not draining</b></p> <ol style="list-style-type: none"> <li>1. Inspect the drain hose for clogs or kinks.</li> <li>2. Check the drain pump for blockages.</li> <li>3. Ensure the air gap or garbage disposal (if connected) is not clogged.</li> </ol> <p><b>Leaking water</b></p> <ol style="list-style-type: none"> <li>1. Inspect the door seal for damage.</li> <li>2. Check the float switch for proper operation.</li> <li>3. Ensure the dishwasher is level.</li> </ol>

Common issues Of Household appliances	Troubleshooting Steps
<b>Oven/Stove</b>	<p><b>Not heating</b></p> <ol style="list-style-type: none"> <li>1. Check the heating element or burner for damage.</li> <li>2. Ensure the thermostat is working correctly.</li> <li>3. For gas stoves, check the igniter.</li> </ol> <p><b>Uneven cooking</b></p> <ol style="list-style-type: none"> <li>1. Calibrate the oven temperature settings.</li> <li>2. Check the oven door seal.</li> <li>3. Ensure proper air circulation inside the oven.</li> </ol> <p><b>Gas smell</b></p> <ol style="list-style-type: none"> <li>1. Turn off the gas supply immediately.</li> <li>2. Ventilate the area.</li> <li>3. Contact a professional to inspect the gas lines and connections.</li> </ol>
<b>Microwave</b>	<p><b>Not heating</b></p> <ol style="list-style-type: none"> <li>1. Check the door switch for proper operation.</li> <li>2. Inspect the magnetron for damage.</li> <li>3. Ensure the control board is functioning.</li> </ol> <p><b>Sparking</b></p> <ol style="list-style-type: none"> <li>1. Clean the microwave interior to remove any food debris.</li> <li>2. Check for damaged waveguide covers.</li> <li>3. Avoid using metal objects or aluminium foil inside.</li> </ol> <p><b>Unusual noises</b></p> <ol style="list-style-type: none"> <li>1. Ensure the turntable is properly aligned.</li> <li>2. Check for loose components.</li> </ol>

Common issues Of Household appliances	Troubleshooting Steps
<b>Safety precautions of household appliances</b>	<ol style="list-style-type: none"> <li>1. <b>Unplug the appliance:</b> Always unplug an appliance from the power source before inspecting or repairing an appliance.</li> <li>2. <b>Consult professionals:</b> For complex issues, especially with gas appliances or major electrical repairs, contact a professional technician.</li> <li>3. <b>Use safety gear:</b> Wear appropriate safety gear such as gloves and safety glasses.</li> <li>4. <b>Follow manufacturer instructions:</b> Adhere to the manufacturer’s guidelines and warnings.</li> </ol>

### Learning tasks

1. Identify the sources of electrical energy.
2. Calculate the voltage and current across a given electrical component.
3. Calculate the electrical power consumption of a given electrical appliance.
4. Describe how to troubleshoot household appliances.

## PEDAGOGICAL EXEMPLARS

### 1. Role-play

- a. Conduct a role-play task whereby learners work in pairs to act as a ‘client’ and an ‘electrical engineer’. Learners should first of all study the table of common appliance issues given above. Learner 1 should then present an issue (e.g. “my dishwasher is leaking water”) to Learner 2, who should describe the troubleshooting process.

### 2. Activity-based learning

- a. Provide materials for learners in their mixed groups to build simple electric circuits using components like batteries, wires, switches, resistors, and bulbs. Guide them through measuring current (in Amperes), voltage (in Volts), and resistance (in Ohms) using multimeters.
- b. Provide scaffolding support for learners who may face challenges and assign roles such as group leader and secretary to group members. This approach promotes 21st-century skills and national core values while also considering

cross-cutting issues such as Gender Equality and Social Inclusion (GESI) and Social and Emotional Learning (SEL).

### 3. Problem-based learning

- a. Put learners in mixed groups, considering GESI, SEL and other cross-cutting issues.
- b. Provide learners with worksheets guiding them through some worked examples using the formulae for calculating current, voltage and power. Learners should then solve a series of problems of increasing difficulty, incorporating both series and parallel circuits.
  - More able learners should be expected to tackle problems involving parallel circuits with multiple components on each branch and should be able to convert units with prefixes to the standard unit.

## KEY ASSESSMENT

**Level 1:** Give the units for voltage, current, power and charge.

**Level 2:** A resistor has a resistance of 10 Ohms, and the current flowing through it is 2 Amps. What is the voltage across the resistor?

**Level 3:** Describe the steps involved in troubleshooting household appliance.

### Hint



The recommended mode of assessment for week 13 is **computational tasks**. Use the level 2 question 2 as a sample question.

## WEEK 14

**Learning Indicator:** *Explain the concept of electrical energy and power*

### FOCAL AREA: ENERGY AUDITS AND SAVINGS PLANS

An energy audit thoroughly examines energy use in a building to identify inefficiencies and savings opportunities. An energy audit is an inspection, survey, and analysis of energy flows to identify energy savings opportunities in a building, process, or system. Its goal is to reduce the amount of energy input into the system without negatively affecting the output(s). An energy audit is key to developing an energy management program.

#### Sources of electrical energy

Electrical energy can be generated from various sources each with specific environmental impacts.

##### *Non – renewable energy*

**Coal:** Burning coal heats water to produce steam and spins generators' turbines.

**Natural gas:** Combustion of natural gas generates heat to produce steam or directly drive turbines.

**Oil:** Oil-fired power plants burn oil to produce steam for turbines.

##### *Renewable energy*

**Nuclear power:** Nuclear fission of uranium or plutonium generates heat, producing steam that drives turbines.

**Hydropower:** Flowing water from rivers or dams' spins turbines connected to generators.

**Wind power:** Wind turbines convert wind's kinetic energy into electrical energy.

**Photovoltaic (PV) solar:** Solar panels convert sunlight directly into electricity using semiconductor materials.

**Concentrated solar power (CSP):** Mirrors concentrate sunlight to heat a fluid, producing steam that drives turbines.

**Geothermal energy:** Heat from the Earth's interior produces steam that drives turbines.

**Biomass:** Organic materials (wood, crop waste) are combusted or converted into biofuels (and then combusted) to generate electricity via the production of steam which flows through a turbine.

**Tidal and wave energy:** Harnessing the kinetic energy of ocean tides and waves to generate electricity.

**Hydrogen fuel cells:** Hydrogen reacts with oxygen in fuel cells to produce electricity and water.

## Energy losses: Heating effects of electric current

When an electric current passes through a wire, the wire gets hot. This is known as the heating effect of electric current / Joule heating.

When an electric current flows through a conductor, such as a wire, the free electrons in the wire collide with the ions in the conductor. These collisions cause the atoms to vibrate more, increasing the thermal energy of the conductor and thus raising its temperature.

### *Applications*

- I. **Electric heaters:** Devices like electric stoves, irons, and room heaters utilise the heating effect of current to generate heat for cooking, ironing clothes, and heating spaces.
- II. **Incandescent light bulbs:** These bulbs pass current through a filament, heating it until it glows and produces light.
- III. **Fuses:** Fuses are safety devices that protect electrical circuits. They contain a thin wire that melts and breaks the circuit when excessive current generates too much heat, preventing damage to the circuit.

### *Implications for device efficiency*

- I. **Energy loss:** In electrical systems, the heating effect can lead to energy loss, especially in transmission lines where some electrical energy is converted to heat.
- II. **Component damage:** Excessive heating can damage electrical components, leading to malfunction or failure. Proper heat dissipation mechanisms, such as heat sinks and cooling fans, are often used to manage this effect in electronic devices.

## EXPERIMENT 14.1 - Heating effect of electric current

**Aim:** Demonstrate the heating effect of electric current.

**Apparatus:** An electric cell, a bulb, a switch, and a connecting wire is required, battery or power supply, thermometer or thermocouple (optional, for precise temperature measurement), heat-resistant gloves (for safety when touching the bulb), heat-resistant surface (such as a ceramic tile or piece of glass)

### Procedure

1. Connect the light bulb to the power supply using connecting wires. Ensure the switch is included in the circuit to control the current flow. Place the setup on a heat-resistant surface to prevent damage or fire hazards.

2. Ensure the switch is in the 'OFF' position. In this state, no current flows through the circuit, and the light bulb does not glow. Touch the light bulb with your hand to feel its initial temperature. The bulb should be at room temperature.
3. Turn the switch to the 'ON' position to allow current to flow through the circuit. Observe that the light bulb begins to glow as the current flows through it, indicating that electrical energy is being converted into light and heat energy.
4. After glowing the bulb (e.g., 1-2 minutes), turn the switch to the 'OFF' position to stop the current flow. Carefully touch the light bulb again using heat-resistant gloves. Observe the bulb's temperature.

**Note:** that the bulb's temperature was normal (room temperature) when the switch was in the 'OFF' position. After the bulb has been glowing, it should feel noticeably warmer, indicating that its temperature has increased due to the heating effect of the electric current.

### Observation

1. When the switch is 'OFF', the bulb does not glow, and its temperature is normal (room temperature).
2. When the switch is turned 'ON', the bulb glows, and after some time, the temperature of the bulb increases significantly.

### Safety Precautions

1. Use heat-resistant gloves when touching the bulb after it has been switched 'ON' to prevent burns.
2. Ensure all connections are secure to avoid short circuits.
3. Handle the power supply carefully to prevent electrical shock.
4. Experiment on a heat-resistant surface to avoid damage or fire hazards.

## Electrical energy in the home

### Calculate the energy consumed by meter reading

As energy consumption becomes a more significant part of our daily lives, understanding how to read your electric meter and calculate your electricity bill can empower you to manage your energy usage more effectively. Energy consumption can be simply said to be the use of a specific amount of energy or power output. Energy is measured in terms of Joules, the standard unit of energy measurement, so energy consumption is typically observed in Giga-Joules per year. However, on most meters (such as the one shown below) it is measured in kWh (kilowatt hours). This is also often how the price of electricity is quoted from the supplier (in Cedis per kWh).

A single kWh is  $1000 \times 60 \times 60 = 3,600,000$  Joules.

## Different types of meters

Electric meters have evolved significantly over the years. While analogue meters were once the standard, most homes now use digital or smart meters. Each type has its method of operation and reading.

### Analogue meters

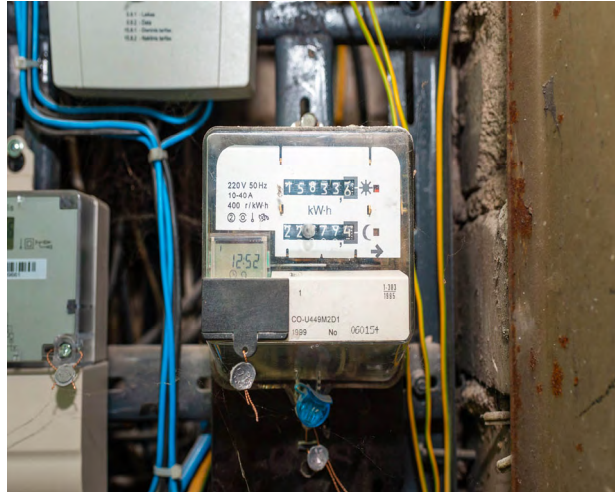

**Fig.13.4** : Analogue electric meter

Analogue meters, also known as electromechanical meters, are the traditional type. They have a series of dials that rotate as electricity is used. Each dial represents a digit in a multi-digit number, which indicates the total electricity consumption in kilowatt-hours (kWh).

### How to read an analogue electric meter

Reading an analogue meter requires some practice but is straightforward once you get the hang of it.

1. **Identify the dials:** Analog meters typically have five dials, each numbered from 0 to 9.
2. **Read each dial:** Start from the left and read each dial sequentially. Note that some dials rotate clockwise while others rotate counterclockwise.
3. **Record the numbers:** Write down the number to which each pointer is closest. If the pointer is between two numbers, record the lower number.
4. **Calculate usage:** Subtract the previous reading from the current reading to determine the kWh used. For example, if the previous reading was 12345 kWh and the current reading is 12400 kWh, you have used 55 kWh.

### Digital meters

Digital meters display electricity usage numerically, like how numbers appear on a digital clock. They are easier to read than analogue meters because they don't require interpreting dials.



Fig. 13.5: Digital electric meter

### Energy audit process

**Initial Assessment:** Gather basic information about the building, including size, age, and primary functions. Collect historical energy consumption data from utility bills for at least the past year, where possible these bills should highlight any seasonal variations.

**Walkthrough Inspection:** Perform a walkthrough of the building to observe energy use and identify inefficiencies. Inspect lighting, HVAC systems, appliances, insulation, windows, and doors. These should be cross checked against the Initial assessment to Identify any areas where the energy consumption data does not appear to match the actual energy use.

**Detailed Analysis:** Energy monitoring equipment will be used to measure the performance of various systems. Identify high-energy-consuming equipment and areas with poor insulation or air leaks. Analyse the efficiency of HVAC systems, lighting, and appliances.

**Evaluate Occupant Behaviour:** Understand how occupants use energy by observing behaviour and conducting interviews or surveys. Identify habits leading to unnecessary energy use, such as leaving lights on or setting too high/low thermostats. This should take into account shift patterns, seasonal variations, specific staff members on shift etc.

**Report Findings:** Compile data and observations into a comprehensive report. Highlight areas of significant energy waste and prioritise them based on potential savings and ease of implementation.

## Home energy savings plan

Creating a home energy savings plan involves setting clear goals, identifying energy-saving opportunities, implementing measures, and monitoring progress.

### Set goals

Define specific, measurable, achievable, relevant, and time-bound (SMART) goals.

Examples include:

1. Reduce overall energy consumption by 15% within one year.
2. Decrease electricity usage by 10% in six months.
3. Cut heating and cooling costs by 20% over the next year.

### Identify energy-saving opportunities

Based on an initial assessment of your home, identify areas where energy savings can be achieved. Common areas include:

<p><b>Lighting</b></p>	<ol style="list-style-type: none"> <li>1. <b>Replace bulbs:</b> Replace incandescent bulbs with energy-efficient LED or CFL bulbs.</li> <li>2. <b>Use sensors:</b> Install motion sensors and timers to reduce unnecessary lighting.</li> <li>3. <b>Maximise natural light:</b> Use natural light where possible and keep windows clean to allow more light in.</li> </ol>
<p><b>Heating, Ventilation, and Air Conditioning (HVAC)</b></p>	<ol style="list-style-type: none"> <li>1. <b>Regular Maintenance:</b> Schedule regular maintenance for HVAC systems to ensure they run efficiently.</li> <li>2. <b>Programmable Thermostats:</b> Install programmable thermostats to automate temperature control based on your schedule.</li> <li>3. <b>Improve Insulation:</b> Add or upgrade insulation in walls, attics, and basements to reduce heating and cooling demands.</li> <li>4. <b>Seal Leaks:</b> Seal gaps and cracks around windows, doors, and other openings to prevent air leaks.</li> </ol>

<b>Appliances and Electronics</b>	<ol style="list-style-type: none"> <li><b>1. Upgrade Appliances:</b> Replace old appliances with Energy Star-rated, more energy-efficient models.</li> <li><b>2. Power Strips:</b> Power strips can easily turn off multiple devices when not in use.</li> <li><b>3. Unplug Devices:</b> Unplug devices when not in use to prevent phantom loads (energy consumption by devices in standby mode).</li> </ol>
<b>Water Heating</b>	<ol style="list-style-type: none"> <li><b>1. Insulate Water Heater:</b> Insulate your water heater and hot water pipes to reduce heat loss.</li> <li><b>2. Low-Flow Fixtures:</b> Install low-flow faucets and showerheads to reduce hot water use.</li> <li><b>3. Temperature Settings:</b> Lower the water heater temperature to a safe and efficient level (120°F is typically recommended).</li> </ol>
<b>Building Envelope</b>	<ol style="list-style-type: none"> <li><b>1. Improve Insulation:</b> Add or improve insulation in walls, attics, and basements.</li> <li><b>2. Energy-Efficient Windows:</b> Replace single-pane windows with double or triple-pane windows.</li> <li><b>3. Seal Openings:</b> Seal gaps and cracks around windows, doors, and other openings to prevent drafts.</li> </ol>
<b>Renewable Energy</b>	<ol style="list-style-type: none"> <li><b>1. Solar Panels:</b> Consider installing solar panels to generate renewable energy for your home.</li> <li><b>2. Incentives and Rebates:</b> Explore incentives and rebates for renewable energy installations in your area</li> </ol>

### ***Develop an implementation plan***

Create a detailed plan to implement the identified energy-saving measures. This plan should include:

- 1. Timeline**
- 2. Responsibilities**
- 3. Budget**

**Example: Home Energy Savings Plan****Goal:** Reduce energy consumption by 20% within one year.

Short-Term Measures (0-3 months)	Medium-Term Measures (3-6 months)	Long-Term Measures (6-12 months)
<p>Replace all incandescent bulbs with LED bulbs.</p> <p>Install programmable thermostats.</p> <p>Conduct a training session for family members on energy-saving behaviours.</p> <p>Unplug devices when not in use to prevent phantom loads.</p>	<p>Upgrade to Energy Star-rated appliances.</p> <p>Seal air leaks around windows and doors.</p> <p>Install low-flow showerheads and faucets.</p> <p>Insulate the water heater and hot water pipes.</p>	<p>Improve insulation in walls, attics, and basements.</p> <p>Replace single-pane windows with energy-efficient models.</p> <p>Install solar panels to generate renewable energy.</p> <p>Explore and apply for energy efficiency incentives and rebates.</p>

**Learning tasks**

1. Identify the key stages in the audit processes of energy
2. Describe and explain the heating effect of electric current
3. Perform an energy audit on your home or school

**PEDAGOGICAL EXEMPLARS****1. Teacher-led learning**

- a. Use PHET simulations, pictures, and videos to explore different sources of electrical energy, such as solar, wind, hydroelectric, and fossil fuels. Discuss with students some advantages and disadvantages of each of these methods but keep this content brief.
- b. Provide learners in their mixed groups videos/charts/pictures/ diagrams of electric meter reading. Let them watch and reflect. Give them a brief explanation of how energy costs are calculated and an approximate cost per kWh of energy.
  - Task each group to demonstrate how to read electric meters and calculate energy consumption in kWh. Extend this to get learners to calculate the cost of energy user for various appliances.

- c. Using visual aids, explain the heating effect of an electric current to the learners. Ask them to summarise the information in their own words with the aid of a diagram; give them 10 minutes to do this. Then, provide them with a mark scheme so that they can check their work and make edits/corrections in a different colour. Less able learners will benefit from a list of key words to help them to form their summary.
- d. Provide scaffolding support for learners who may face challenges and assign roles such as group leader and secretary to group members. This approach promotes 21st-century skills and national core values while also considering cross-cutting issues such as Gender Equality and Social Inclusion (GESI) and Social and Emotional Learning (SEL).

## 2. Collaborative learning

- a. Provide learners with a summary of the steps involved in an energy audit, including common areas of consideration when analysing energy losses in a building. In mixed ability groups, guide each group to perform an energy audit of their homes or of the school. They should also produce an action plan, including short-, medium- and long-term goals for the school to achieve a target.
  - Learners should present their findings either orally or by way of a poster presentation and gallery walk.
- b. Provide scaffolding support for learners who may face challenges, and assign roles such as group leader and secretary to group members. This approach promotes 21st-century skills and national core values, while also considering cross-cutting issues such as Gender Equality and Social Inclusion (GESI) and Social and Emotional Learning (SEL)

## 3. Experiential learning

- a. Provide diagrams and animations to show how electric current produces heat in a conductor to learners.
- b. Let learners in mixed groups perform a simple lab experiment where they measure the temperature rise in different wires (varying materials and thicknesses) when a current is passed through them. Provide a lab worksheet to guide the process.
  - Encourage learners to write report on their observations and compare results.
  - Have learners submit lab reports explaining their experiments, observations, and conclusions.
  - Organise peer review sessions where learners critique each other's lab reports or projects, providing feedback and suggestions for improvement.

- c. Provide scaffolding support for learners who may face challenges, and assign roles such as group leader and secretary to group members. This approach promotes 21st-century skills and national core values, while also considering cross-cutting issues such as Gender Equality and Social Inclusion (GESI) and Social and Emotional Learning (SEL)

## KEY ASSESSMENT

**Level 1:** Identify the key stages in the energy audit processes.

**Level 2:** Describe the heating effect of electric current on a conductor.

**Level 3:** Conduct an experiment to investigate heat loss from conductors of varying dimensions and produce a report of your findings.

### Hint



The recommended mode of assessment for week 14 is **peer-assessment**. Use the level 1 question as a sample question.

**WEEK 15**

**Learning Indicator:** Explain the principle of the transformer and its function.

## FOCAL AREA: PRINCIPLE OF TRANSFORMER AND ITS FUNCTION

### Concept of Transformers

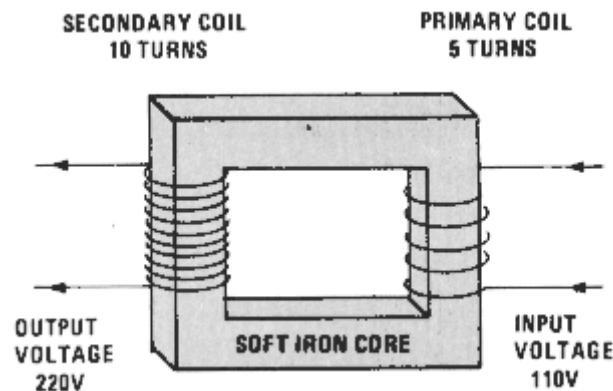

**Fig. 15.1:** A well-labelled diagram of a Transformers

Transformers are electrical devices that are used to increase (step-up) or decrease (step-down) voltage levels in power systems. A transformer consists of two windings, called the primary and secondary windings, which are wound around a common core made of a ferromagnetic material (such as iron). The primary winding receives the alternating current (AC) from the power source, creating a magnetic field in the core, which then induces a voltage in the secondary winding.

### Key definitions

**Electromagnetic induction:** The method through which a changing magnetic field generates a voltage in a conductor.

**Primary winding:** The coil that is connected to the power source input.

**Secondary winding:** The coil is connected to the output circuit where the modified voltage is required.

**Core:** The magnetic component that improves the efficiency of the magnetic flux connection between the primary and secondary coils.

### Types of transformers

#### Step-down transformer

**Definition:** A step-down transformer is designed to reduce voltage from the primary to the secondary winding while proportionally increasing the current. This is achieved by

having fewer wire turns on the secondary winding than the primary winding. This is shown in the figure on the previous page.

Purpose: Designed to reduce the voltage to a safe value.

### *Step-up transformer*

Definition: A step-up transformer is designed to increase voltage from the primary to the secondary winding while proportionally decreasing the current. This is accomplished by having more wire turns on the secondary winding than on the primary winding.

Purpose: Designed to increase the voltage and thereby reduce the current, which reduces the effect of electrical heating and makes energy transfer more efficient over long distances.

## EXPERIMENT 15.1 - Experiment to build a step-down transformer

**Safety note:** Allowing learners to construct their own transformers could cause exceedingly high voltages to be generated! This will need to be very carefully managed.

Learners must not exceed a 1:10 ratio of turns

Learners must not exceed an input voltage of 2V AC, this should be locked off where possible on the power supplies.

Learners must not attempt to build a step-up transformer.

**Aim:** To build a step-down transformer.

**Apparatus:** Iron core (you can salvage this from an old transformer or buy one), insulated copper wire (different gauges for primary and secondary coils), wire cutter/stripper, soldering iron and solder, electrical tape, AC signal generator and multimeter (for testing).

### Procedure

1. Calculate the turns ratio: Determine the ratio between the number of turns in the primary and secondary coil needed for your step-down transformer. For example, if you desire a 1:2 step-down transformer, the primary coil should have twice as many turns as the secondary coil.
2. Prepare the core: Place the Iron core on a flat surface, ensuring it is clean and free of debris or dust.
3. Wind the coils:

**Primary Coil:** Wind the calculated number of turns around one side of the iron core, leaving sufficient wire for connecting to a power source.

**Secondary Coil:** Wind the secondary coil with the predetermined number of turns on the opposite side of the core. This coil will output the reduced voltage.

4. **Connect the leads:** Securely connect the ends of the primary and secondary coils to their respective terminals. Use a soldering iron to make firm connections and insulate them thoroughly with electrical tape.
5. **Apply a low-voltage AC signal** to the primary coil and measure the voltage across the secondary coil. Ensure the measured output voltage aligns with your calculations based on the turn ratio.

### Learning tasks

1. Identify the functions of step-up and down transformers
2. Describe the principle of step-up transformer and step-down transformer
3. Build a transformer model through hands-on activities.

## PEDAGOGICAL EXEMPLARS

### 1. Talk-for learning

- a. Use talk-for-learning to discuss the theory behind transformers, focusing on electromagnetic induction and the turns ratio. Emphasise the purpose of transformers in mains electricity and link this to the previous work on the heating effect of a current.
- b. Put them into mixed groups and provide visual aids, such as diagrams, videos, or animations, to illustrate how transformers work.
- c. Task each learner to create summary notes.
- d. Provide scaffolding support for learners who may face challenges and assign roles such as group leader and secretary to group members. This approach promotes 21st-century skills and national core values while also considering cross-cutting issues such as Gender Equality and Social Inclusion (GESI) and Social and Emotional Learning (SEL)

### 2. Experiential learning

- a. Use demonstrations, models, and simulations to represent abstract concepts like transformer operation to guide learners visually through the process. Incorporate multimedia resources like Physics Education Technology (PHET) simulations, videos, and animations to enhance understanding. Encourage learners to ask questions about the simulation.

- b. Provide materials and guidance for learners in their mixed group to build their transformer models. Ensure safety precautions are followed, especially when dealing with electricity.
  - i. Guide learners in their mixed groups through the winding and assembly process step-by-step.
  - ii. Offer assistance and feedback as they work on their models.
- c. Guide learners to conduct hands-on activities to explore electromagnetism and induction principles using simple materials like coils, magnets, and batteries.
- d. Provide scaffolding support for learners who may face challenges and assign roles such as group leader and secretary to group members. This approach promotes 21st-century skills and national core values while also considering cross-cutting issues such as Gender Equality and Social Inclusion (GESI) and Social and Emotional Learning (SEL)

### 3. Problem-based learning

- a. Provide learners with a worksheet of questions to use the turns ratio / input and output voltage relationship to calculate the missing values in various scenarios.
  - i. More able learners should be expected to use the formula  $P=IV$  in order to calculate the current as well as the voltage across each coil, if provided with the efficiency of the transformer.

### 4. Field trip

- a. Guide learners to take a gallery walk/field trip to the community to look at transformers and electrical circuits in everyday life, such as power distribution networks, household appliances, and renewable energy systems. This will help learners connect theoretical knowledge to practical applications. Take care to observe all safety signage in place.
- b. Put learners in mixed groups and organise a session for a whole-class discussion on the observations made by learners during the field trip.
- c. Provide scaffolding support for learners who may face challenges and assign roles such as group leader and secretary to group members. This approach promotes 21st-century skills and national core values while also considering cross-cutting issues such as Gender Equality and Social Inclusion (GESI) and Social and Emotional Learning (SEL)

## KEY ASSESSMENT

**Level 1:** Identify at least four functions of a transformer

**Level 2:** Describe the principle of step-up and step-down transformers

### Level 3

1. Build a transformer through hands-on activity in the laboratory.
2. Carefully read each clue provided for the crossword puzzle. The clues are based on the transformer principles and functions you have studied. All spaces in the crossword puzzle should be filled.

## Transformer Principles and Functions

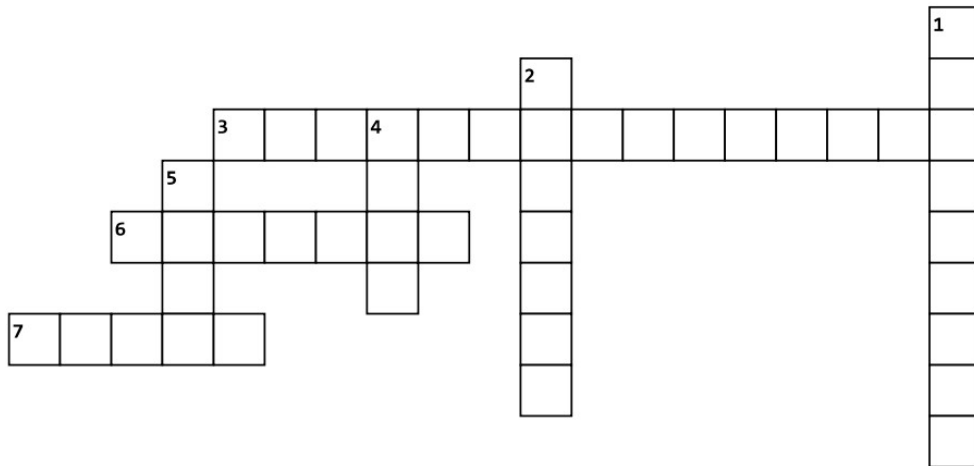

#### Across

- 3.** Induction - The process of generating voltage through a changing magnetic field.
- 6.** Winding - The coil connected to the power source input.
- 7.** 2. Step-up Transformer - A transformer designed to increase voltage from primary to secondary. **4.** Step-down Transformer - A transformer designed to reduce voltage from primary to secondary. **6.** Current - The electrical flow that is inversely adjusted by transformers with voltage. **8.** Safety - A crucial consideration when handling electrical devices like transformers.

#### Down

- 1.** Winding - The coil that delivers the modified output voltage.
- 2.** - The main parameter that a transformer steps up or down.
- 4.** - The magnetic component that enhances magnetic flux between coils.
- 5.** - A common ferromagnetic material used in transformer cores.

#### Hint



The recommended mode of assessment for week 15 is **gamification**. Use the level 3 question 2 as a sample question.





## Section 4 review

This section review provides a foundational understanding of electrical energy and power, essential for efficient electricity usage in various applications. In Weeks 13 and 14, the concepts of electrical energy and power were explored, emphasizing that electrical energy is the work done by an electric current, calculated as the

product of voltage and current. Power, measured in watts, represents the rate at which this energy is transferred. In Week 15, the principle of the transformer was introduced, explaining its role in efficiently transferring electrical energy between circuits through electromagnetic induction, allowing for the stepping up or down of voltage to facilitate power transmission.

## ADDITIONAL READING

Follow the links or scan the QR codes below for videos

1. Video on meter reading. <a href="https://www.youtube.com/watch?v=L_A0c0w0dMs">https://www.youtube.com/watch?v=L_A0c0w0dMs</a>	
2. Video on heating effect of electric current <a href="https://www.youtube.com/watch?v=zzmHjg0PORY">https://www.youtube.com/watch?v=zzmHjg0PORY</a>	
3. Video on how to make electric cells <a href="https://www.youtube.com/watch?v=AWEdpTOtL6M">https://www.youtube.com/watch?v=AWEdpTOtL6M</a>	
3. Video on how to build a simple transformer. <a href="https://www.youtube.com/watch?v=lsfWDx3VXDg">https://www.youtube.com/watch?v=lsfWDx3VXDg</a>	

## MARKING SCHEME FOR THE COMPUTATIONAL ASSESSMENT TASK

Ohm's Law,  $V = IR$  (1 mark)

$I = 2A$  and  $R = 10\Omega$

$V = 2 * 10$  Substitution of numbers (1 mark)

$V = 20V$  Final answer= (2 mark)

# MARKING SCHEME FOR THE GAMIFICATION ASSESSMENT TASK

## Transformer Principles and Functions

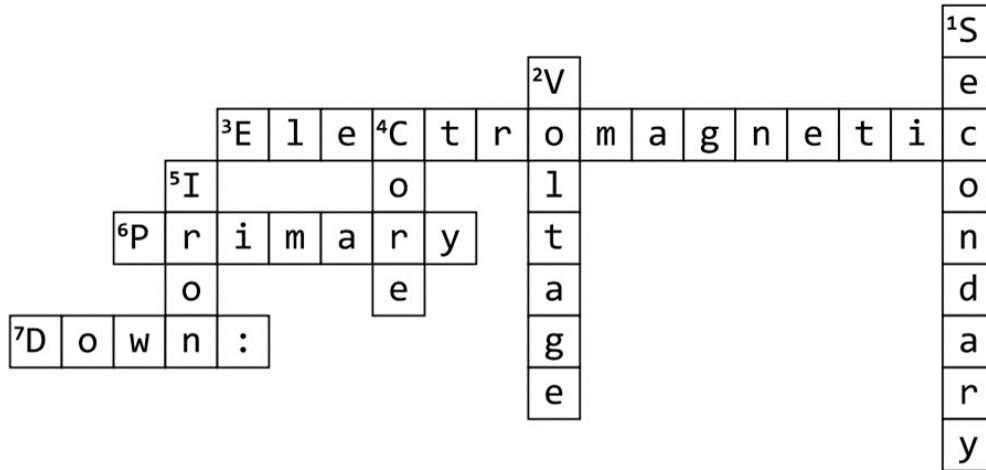

### Across

- 3.** Induction - The process of generating voltage through a changing magnetic field.
- 6.** Winding - The coil connected to the power source input.
- 7.** 2. Step-up Transformer - A transformer designed to increase voltage from primary to secondary. **4.** Step-down Transformer - A transformer designed to reduce voltage from primary to secondary. **6.** Current - The electrical flow that is inversely adjusted by transformers with voltage. **8.** Safety - A crucial consideration when handling electrical devices like transformers.

### Down

- 1.** Winding - The coil that delivers the modified output voltage.
- 2.** - The main parameter that a transformer steps up or down.
- 4.** - The magnetic component that enhances magnetic flux between coils.
- 5.** - A common ferromagnetic material used in transformer cores.

- a) Correctly identifying and spelling each term (1 mark)
- b) the terms related to transformer principles and functions, such as Step-up - Type of transformer that increases voltage (2 marks)
- c) Group that finishes first (1 mark)

Total score= 22 marks



## APPENDIX E: INDIVIDUAL PROJECT

**Task:** Produce a named local indigenous beverage in your community and present it at week 21.

### **How to administer**

Provide clear guidelines for developing the project and assessing it.

Provide and use ongoing feedback and guidance to learners.

Refer to Teacher Assessment Manual and Toolkits, pages 77-80, for more information on how to administer report writing.

## Rubrics

Criteria	Excellent (4)	Proficient (3)	Basic (2)	Needs Improvement (1)
<b>Research and Planning</b>	<p>Showing any 4 of these:</p> <ol style="list-style-type: none"> <li>Identification of the beverage: Clear choice of a specific indigenous beverage.</li> <li>Understanding of ingredients: Detailed list of locally sourced ingredients.</li> <li>The step-by-step process is outlined as comprehensive and logical preparation steps.</li> <li>Historical and cultural relevance: Explanation of the beverage's significance in the community.</li> </ol>	<p>Showing any 3 of these:</p> <ol style="list-style-type: none"> <li>Identification of the beverage: Clear choice of a specific indigenous beverage.</li> <li>Understanding of ingredients: Detailed list of locally sourced ingredients.</li> <li>The step-by-step process is outlined as comprehensive and logical preparation steps.</li> <li>Historical and cultural relevance: Explanation of the beverage's significance</li> </ol>	<p>Showing any 2 of these:</p> <ol style="list-style-type: none"> <li>Identification of the beverage: Clear choice of a specific indigenous beverage.</li> <li>Understanding of ingredients: Detailed list of locally sourced ingredients.</li> <li>The step-by-step process is outlined as comprehensive and logical preparation steps.</li> <li>Historical and cultural relevance: Explanation of the beverage's significance</li> </ol>	<p>Showing any 1 of these:</p> <ol style="list-style-type: none"> <li>Identification of the beverage: Clear choice of a specific indigenous beverage.</li> <li>Understanding of ingredients: Detailed list of locally sourced ingredients.</li> <li>The step-by-step process is outlined as comprehensive and logical preparation steps.</li> <li>Historical and cultural relevance: Explanation of the beverage's significance</li> </ol>

Criteria	Excellent (4)	Proficient (3)	Basic (2)	Needs Improvement (1)
Quality of Beverage Produced	<p>Showing any 4 of these:</p> <ul style="list-style-type: none"> <li>a. Authenticity: Adheres to traditional preparation methods.</li> <li>b. Taste: Achieves the expected flavour profile for the beverage.</li> <li>c. Presentation: Appealing and culturally appropriate serving style.</li> <li>d. Consistency: Ensures uniformity in texture, flavour, or appearance.</li> <li>e. Hygiene: Maintains cleanliness throughout the production process.</li> </ul>	<p>Showing any 3 of these:</p> <ul style="list-style-type: none"> <li>a. Authenticity: Adheres to traditional preparation methods.</li> <li>b. Taste: Achieves the expected flavour profile for the beverage.</li> <li>c. Presentation: Appealing and culturally appropriate serving style.</li> <li>d. Consistency: Ensures uniformity in texture, flavour, or appearance.</li> <li>e. Hygiene: Maintains cleanliness throughout the production process.</li> </ul>	<p>Showing any 2 of these:</p> <ul style="list-style-type: none"> <li>a. Authenticity: Adheres to traditional preparation methods.</li> <li>b. Taste: Achieves the expected flavour profile for the beverage.</li> <li>c. Presentation: Appealing and culturally appropriate serving style.</li> <li>d. Consistency: Ensures uniformity in texture, flavour, or appearance.</li> <li>e. Hygiene: Maintains cleanliness throughout the production process.</li> </ul>	<p>Showing any 1 of these:</p> <ul style="list-style-type: none"> <li>a. Authenticity: Adheres to traditional preparation methods.</li> <li>b. Taste: Achieves the expected flavour profile for the beverage.</li> <li>c. Presentation: Appealing and culturally appropriate serving style.</li> <li>d. Consistency: Ensures uniformity in texture, flavour, or appearance.</li> <li>e. Hygiene: Maintains cleanliness throughout the production process.</li> </ul>

Criteria	Excellent (4)	Proficient (3)	Basic (2)	Needs Improvement (1)
Creativity and Innovation	<p>Showing any 4 of these:</p> <ol style="list-style-type: none"> <li>Unique twist on the beverage: Adds a new element while maintaining authenticity.</li> <li>Use of local materials: Incorporates innovative tools or techniques from the community.</li> <li>Creative and culturally relevant packaging if applicable.</li> <li>Eco-friendly methods or materials used.</li> <li>Demonstrates how the beverage can be adapted for broader appeal.</li> </ol>	<p>Showing any 3 of these:</p> <ol style="list-style-type: none"> <li>Unique twist on the beverage: Adds a new element while maintaining authenticity.</li> <li>Use of local materials: Incorporates innovative tools or techniques from the community.</li> <li>Creative and culturally relevant packaging if applicable.</li> <li>Eco-friendly methods or materials used.</li> <li>Demonstrates how the beverage can be adapted for broader appeal.</li> </ol>	<p>Showing any 2 of these:</p> <ol style="list-style-type: none"> <li>Unique twist on the beverage: Adds a new element while maintaining authenticity.</li> <li>Use of local materials: Incorporates innovative tools or techniques from the community.</li> <li>Creative and culturally relevant packaging if applicable.</li> <li>Eco-friendly methods or materials used.</li> <li>Demonstrates how the beverage can be adapted for broader appeal.</li> </ol>	<p>Showing any 1 of these:</p> <ol style="list-style-type: none"> <li>Unique twist on the beverage: Adds a new element while maintaining authenticity.</li> <li>Use of local materials: Incorporates innovative tools or techniques from the community.</li> <li>Creative and culturally relevant packaging if applicable.</li> <li>Eco-friendly methods or materials used.</li> <li>Demonstrates how the beverage can be adapted for broader appeal.</li> </ol>

Criteria	Excellent (4)	Proficient (3)	Basic (2)	Needs Improvement (1)
<b>Documentation and Presentation</b>	<p>Showing any 4 of these:</p> <ul style="list-style-type: none"> <li>a. Detailed written report includes background, steps, and challenges faced.</li> <li>b. Photos or videos documenting the production process.</li> <li>c. Well-organized and engaging explanation of the project.</li> <li>d. Highlights the beverage's role in community life.</li> <li>e. Meets project deadlines and allocates time effectively during presentation.</li> </ul>	<p>Showing any 3 of these:</p> <ul style="list-style-type: none"> <li>a. Detailed written report includes background, steps, and challenges faced.</li> <li>b. Photos or videos documenting the production process.</li> <li>c. Well-organized and engaging explanation of the project.</li> <li>d. Highlights the beverage's role in community life.</li> <li>e. Meets project deadlines and allocates time effectively during presentation.</li> </ul>	<p>Showing any 2 of these:</p> <ul style="list-style-type: none"> <li>a. Detailed written report includes background, steps, and challenges faced.</li> <li>b. Photos or videos documenting the production process.</li> <li>c. Well-organized and engaging explanation of the project.</li> <li>d. Highlights the beverage's role in community life.</li> <li>e. Meets project deadlines and allocates time effectively during presentation.</li> </ul>	<p>Showing any 1 of these:</p> <ul style="list-style-type: none"> <li>a. Detailed written report includes background, steps, and challenges faced.</li> <li>b. Photos or videos documenting the production process.</li> <li>c. Well-organized and engaging explanation of the project.</li> <li>d. Highlights the beverage's role in community life.</li> <li>e. Meets project deadlines and allocates time effectively during presentation.</li> </ul>

Criteria	Excellent (4)	Proficient (3)	Basic (2)	Needs Improvement (1)
<b>Teamwork and Collaboration</b>	<p>Showing any 4 of these:</p> <ul style="list-style-type: none"> <li>a. Role distribution: Clear allocation of tasks among team members.</li> <li>b. Communication: Effective coordination and exchange of ideas.</li> <li>c. Problem-solving: Ability to address challenges collaboratively.</li> <li>d. Respect and inclusivity: Ensures equal participation and values each member's input.</li> <li>e. Reflection on teamwork: Evaluate group dynamics and individual contributions in the final report.</li> </ul>	<p>Showing any 4 of these:</p> <ul style="list-style-type: none"> <li>a. Role distribution: Clear allocation of tasks among team members.</li> <li>b. Communication: Effective coordination and exchange of ideas.</li> <li>c. Problem-solving: Ability to address challenges collaboratively.</li> <li>d. Respect and inclusivity: Ensures equal participation and values each member's input.</li> <li>e. Reflection on teamwork: Evaluate group dynamics and individual contributions in the final report.</li> </ul>	<p>Showing any 4 of these:</p> <ul style="list-style-type: none"> <li>a. Role distribution: Clear allocation of tasks among team members.</li> <li>b. Communication: Effective coordination and exchange of ideas.</li> <li>c. Problem-solving: Ability to address challenges collaboratively.</li> <li>d. Respect and inclusivity: Ensures equal participation and values each member's input.</li> <li>e. Reflection on teamwork: Evaluate group dynamics and individual contributions in the final report.</li> </ul>	<p>Showing any 4 of these:</p> <ul style="list-style-type: none"> <li>a. Role distribution: Clear allocation of tasks among team members.</li> <li>b. Communication: Effective coordination and exchange of ideas.</li> <li>c. Problem-solving: Ability to address challenges collaboratively.</li> <li>d. Respect and inclusivity: Ensures equal participation and values each member's input.</li> <li>e. Reflection on teamwork: Evaluate group dynamics and individual contributions in the final report.</li> </ul>

### Feedback

Guide learners in reflecting on their project-based assessments and help them develop metacognitive skills, etc.

## RUBRICS FOR THE PEER-ASSESSMENT TASK

Criteria	Excellent 4	Proficient (3)	Basic (2)	Needs Improvement (1)
Presents the stages in logical order.	<p>Identifies any 7-8 essential stages of energy audit processes:</p> <p>a. Conduct a quick facility walk-through to observe energy usage patterns.</p> <p>b. Review historical energy bills and consumption data to understand baseline energy use.</p> <p>c. Identify major energy-consuming equipment and systems, such as HVAC, lighting, and machinery.</p> <p>a. Conduct brief interviews with facility managers and staff to understand operational practices.</p>	<p>Identifies any 5-6 essential stages of energy audit processes:</p> <p>a. Conduct a quick facility walk-through to observe energy usage patterns.</p> <p>b. Review historical energy bills and consumption data to understand baseline energy use.</p> <p>c. Identify major energy-consuming equipment and systems, such as HVAC, lighting, and machinery.</p> <p>d. Conduct brief interviews with facility managers and staff to understand operational practices.</p>	<p>Identifies any 4 essential stages of energy audit processes:</p> <p>a. Conduct a quick facility walk-through to observe energy usage patterns.</p> <p>b. Review historical energy bills and consumption data to understand baseline energy use.</p> <p>c. Identify major energy-consuming equipment and systems, such as HVAC, lighting, and machinery.</p> <p>d. Conduct brief interviews with facility managers and staff to understand operational practices.</p>	<p>Identifies any 1-2 essential stages of energy audit processes:</p> <p>a. Conduct a quick facility walk-through to observe energy usage patterns.</p> <p>b. Review historical energy bills and consumption data to understand baseline energy use.</p> <p>c. Identify major energy-consuming equipment and systems, such as HVAC, lighting, and machinery.</p> <p>d. Conduct brief interviews with facility managers and staff to understand operational practices.</p>

Criteria	Excellent 4	Proficient (3)	Basic (2)	Needs Improvement (1)
	<p>b. Measure and record energy usage data from meters, sensors, and sub-meters.</p> <p>c. Collect equipment specifications such as efficiency ratings and operating hours).</p> <p>d. Analyse patterns of energy use (daily, weekly, seasonal variations).</p> <p>e. Assess operational and maintenance practices that impact energy consumption.</p>	<p>e. Measure and record energy usage data from meters, sensors, and sub-meters.</p> <p>f. Collect equipment specifications such as efficiency ratings and operating hours).</p> <p>g. Analyse patterns of energy use (daily, weekly, seasonal variations).</p> <p>h. Assess operational and maintenance practices that impact energy consumption</p>	<p>e. Measure and record energy usage data from meters, sensors, and sub-meters.</p> <p>f. Collect equipment specifications such as efficiency ratings and operating hours).</p> <p>g. Analyse patterns of energy use (daily, weekly, seasonal variations).</p> <p>h. Assess operational and maintenance practices that impact energy consumption</p>	<p>e. Measure and record energy usage data from meters, sensors, and sub-meters.</p> <p>f. Collect equipment specifications such as efficiency ratings and operating hours).</p> <p>g. Analyse patterns of energy use (daily, weekly, seasonal variations).</p> <p>h. Assess operational and maintenance practices that impact energy consumption</p>

# SECTION 5: BUOYANCY FORCE

## Strand: Vigour behind life

### Sub-strand: Forces acting on substances and mechanisms

**Learning Outcome:** Explain and apply the concept of upthrust and the law of floatation in real life.

**Content Standard:** Recognise the various types of motions, their applications, and the forms of force that act on the body.

## INTRODUCTION AND SECTION SUMMARY

The relationship between upthrust (buoyant force) and the law of floatation defines why objects float or sink in fluids. A fluid is defined as a gas or liquid e.g. air is a fluid, water is a fluid, honey or mercury are fluids. Upthrust acts upwards on an object immersed in a fluid, countering its weight. According to the law of floatation, an object floats when the buoyant force equals the weight of the fluid it displaces. This principle illustrates that the volume of displaced fluid is directly proportional to the object's weight and determines its buoyancy. Understanding this relationship is crucial in various practical applications, including ship design, life-saving equipment, and environmental studies. It enables engineers and scientists to predict and manipulate buoyancy to design effective floatation devices and understand natural phenomena involving fluid dynamics, ensuring safety and efficiency in aquatic environments.

*The weeks covered by the section are:*

Week 16: *Discuss the relationship between upthrust and the law of floatation.*

## SUMMARY OF PEDAGOGICAL EXEMPLARS

The pedagogical approaches of this section focus on active and collaborative learning to effectively explore the concepts of upthrust and floatation. In collaborative learning, mixed groups engage in discussions using talk-for-learning strategies to delve into the principles of buoyancy. They document their findings and participate in peer reviews, enhancing comprehension through shared insights and cooperative interaction. Experiential learning involves hands-on experiments where groups investigate how various objects float, considering factors like density, volume, and shape. Learners design prototypes based on their research, testing them in water to observe and refine buoyancy

characteristics. This approach encourages the practical application of theoretical knowledge, fostering creativity and problem-solving skills. Problem-based learning challenges groups with real-world scenarios, such as designing boats or life-saving devices, prompting them to apply floatation principles critically. These methods deepen understanding of upthrust and floatation while developing collaborative skills and practical problem-solving abilities in scientific contexts.

## **ASSESSMENT SUMMARY**

Assessing learning in these pedagogical approaches involves diverse methods to evaluate understanding and skills related to upthrust and floatation concepts. Collaborative learning focuses on group discussions and written reflections where learners explore and clarify their understanding through peer reviews, assessing both individual comprehension and teamwork. Experiential learning encourages learners to investigate how different factors like density, volume, and shape affect floatation, culminating in designing and testing prototypes in water. Assessments here include evaluating presentations on prototype design choices and their demonstration of buoyancy principles through practical testing and data analysis. Problem-based learning challenges learners with real-world scenarios, assessing their application of floatation laws in designing solutions such as boats or life-saving devices, measuring critical thinking and problem-solving abilities. These assessments collectively gauge learners' theoretical understanding, practical application, collaborative skills, and innovative problem-solving capabilities in the context of buoyancy and floatation principles.

Teachers can consult the Teacher Assessment Manual and Toolkits (TAMT) (NaCCA, MoE, 2003) for guidance on effectively utilising various assessment strategies.

**WEEK 16**

**Learning Indicator:** Discuss the relationship between upthrust and the law of floatation.

## **FOCAL AREA: THE RELATIONSHIP BETWEEN UPTHRUST AND THE LAW OF FLOATATION**

### **Meaning of upthrust**

Upthrust, also known as buoyant force, is the force exerted by a fluid (liquid or gas) that opposes the weight of an object immersed in it. When an object is placed in a fluid, it experiences an upward force due to the pressure difference between the top and bottom of the object. This force is what makes objects float in some cases.

The principle of upthrust is governed by Archimedes' principle. This states that the upward buoyant force exerted on a body immersed in a fluid, whether partially or fully submerged, is equal to the weight of the fluid that the body displaces. It depends on the density of the fluid and the volume of the object submerged in the fluid.

### **Meaning of floatation**

Floatation is the state of an object being suspended in a liquid, neither sinking nor completely submerged.

### **Density**

Density is defined as mass per unit volume ( $\rho = m/V$ ).

An object will float in a fluid if its density is less than the density of the fluid. Conversely, it will sink if its density exceeds the fluid's.

Explanation: When an object is placed in a fluid, it displaces a fluid volume. If the object is less dense than the fluid, the weight of the displaced fluid is greater than the object's weight, resulting in a net upward buoyant force that causes the object to float. If the object is denser, the weight of the object is greater than the buoyant force, and it sinks.

### **Volume**

This is the amount of space occupied by an object.

A larger volume means a greater amount of fluid is displaced, which increases the buoyant force. Even if an object is made of dense material, its large volume can displace enough fluid to generate a buoyant force that supports its weight.

An object's shape and design can increase its volume without significantly increasing its mass, decreasing its overall density. For example, steel is denser than water and would sink if shaped as a solid block. However, a steel ship is designed with a large hull that

encloses a lot of air, significantly increasing the ship's overall volume without much increase in mass. This decreases the ship's overall density to less than water's, allowing it to float.

*Example: A floating boat*

**Boat's weight:** The boat has a certain weight, which acts downward due to gravity.

**Displaced water:** When placed in water, the boat displaces a volume of water whose displaced weight provides upthrust.

**Equilibrium:** The boat floats when the upthrust (weight of the displaced water) equals the boat's weight. According to the law of floatation, this equilibrium ensures that the boat remains buoyant and stable on the water's surface.

## Application of the law of floatation in real life

	Link to floatation	How does it float?
<b>Ships and boats</b>	Design and construction of ships and boats rely on the law of floatation to ensure they remain buoyant and stable in water.	Ships overcome their considerable weight and steel construction due to Archimedes' principle. When a ship enters the water, its hull pushes down, displacing a substantial volume of water. Importantly, the upward force exerted by the displaced water, known as upthrust, is equal to the weight of the water displaced. The ship's design and internal structure are pivotal despite steel being denser than water. The wide, flat bottom maximises water displacement, while air-filled compartments within the ship add significant volume without much weight. This design combination allows the ship to displace enough water to generate sufficient upthrust to balance its weight, ensuring buoyancy and keeping it afloat.

	Link to floatation	How does it float?
<b>Submarines</b>	Ballast tanks control buoyancy by adjusting their water amount.	Submarines use Archimedes' principle to regulate their depth. They are equipped with ballast tanks on both sides, which adjust to change the amount of water they displace. This adjustment allows submarines to rise towards the surface or sink to greater depths. When a submarine needs to submerge, it fills its ballast tanks with water, increasing its overall density and causing it to sink beneath the ocean's surface. Conversely, when the submarine needs to float on the water's surface, it expels water from the ballast tanks.
<b>Hot air balloons</b>	Hot-air balloons and airships are widely used in air transportation and operate on the principles of floatation.	A hot air balloon operates with three main components: the burner, the balloon itself, and the basket. The burner uses propane gas to heat the air inside the balloon. When the air inside the balloon heats up, it expands, reducing its density compared to the surrounding air, causing the balloon to rise. To descend, the pilot can open a parachute valve at the top of the balloon. This valve allows cooler air to enter, increasing the density inside the balloon and causing it to descend. Alternatively, the pilot can reduce fuel burning to let the air inside the balloon cool down and descend.

## EXPERIMENT 16.1 - Experiment to build prototypes

**Aim:** To build prototypes of ships, canoes and boat

**Apparatus:** Aluminium foil (large sheets), modelling clay (optional, shallow pan or tub filled with water, tape (optional), scissors (optional, for cutting foil), pencils or markers (optional, for decoration)

### Procedure

1. Create a canoe: Take a sheet of aluminium foil and fold it lengthwise several times to create a long, sturdy strip.

2. Gently curve the strip upwards along the centre to form the basic shape of a canoe. If desired, pinch the ends slightly to create pointed tips.
3. For added weight and stability (optional): Pinch small pieces of modelling clay and place them inside the bottom of the canoe, securing them with tape if necessary.
4. Create a ship: Take another sheet of aluminium foil.
5. Fold the sheet in half to create a square, then fold the square diagonally to form a triangle.
6. Slightly open the triangle and fold the bottom corners toward the top point, shaping a basic ship hull with a pointed front and flat bottom.
7. Use tape to reinforce the folds for a sturdier hull.
8. Decoration (Optional):
9. Use markers or pens to decorate your ship and canoe with windows, portholes, or other details.
10. Carefully place your canoe and ship prototypes in the water-filled pan.
11. Observe their behaviour. Do they float? How much water do they displace?
12. For the canoe, adjust the amount of modelling clay to test its impact on stability.
13. For the ship, experiment with altering the hull shape to observe changes in water displacement.

### Observations and Discussion

1. Modifying the ship's hull shape affects its ability to float.

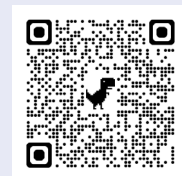

**Fig. 16.1:** A picture of an aluminium foil-made canoe

## EXPERIMENT 16.2 – Investigating upthrust and floatation

**Aim:** Verify the balance of weight with upthrust for objects which are floating.

**Materials needed:** Blocks made of wood/metal/plastic (hollow or solid), a container full of water, a ruler, weighing scales.

### Procedure:

1. Find the mass of each of the blocks, in kg, using weighing scales and record this in a table.
2. Place one of the blocks into the water and observe whether it floats or sinks. For those that float:
3. Measure the depth of the block which has remained submerged in the water. Use this depth to estimate the volume of water displaced in  $\text{m}^3$  (depth (m) x width (m) x length (m)).
4. Multiply the volume of displaced water by the density of water ( $1000\text{kg}/\text{m}^3$ ) to find the mass of water displaced.
5. Compare the weight of the block with the weight of the displaced water. **Note:** weight (N) = mass (kg) x gravitational field strength (N/kg), g. g is  $9.81\text{N}/\text{kg}$  on Earth.
6. Write a conclusion to your investigation, ensuring that you mention the main sources of uncertainty in your experiment.

### Learning Tasks

1. State the law of floatation
2. Explain how the law of floatation can be applied in everyday life.
3. Using the principle of upthrust and floatation, build prototypes of ship and canoes.

## PEDAGOGICAL EXEMPLARS

### 1. Talk-for-learning

- a. Lead a whole-class discussion to help learners understand the concept of upthrust and the law of floatation. Provide learners with simple diagrams to illustrate how upthrust and floatation are applied in everyday life.
- b. Provide scaffolding support for learners who may face challenges, and assign roles such as group leader and secretary to group members. This approach promotes 21st-century skills and national core values while also considering

cross-cutting issues such as Gender Equality and Social Inclusion (GESI) and Social and Emotional Learning (SEL)

## 2. Experiential learning

- a. In mixed-ability groups, task learners with designing and building small boats using various materials (see Experiment 1). Encourage learners to adjust their designs in order to achieve greater submersion or to make an object sink which previously floated. Circulate the room, asking learners differentiated questions such as:

“If the boat is displaced from its equilibrium position (pushed down a little) why does it then return to its equilibrium position? Explain this to me in terms of the forces acting on the boat”

“Why does a ship with a wide base sit in equilibrium at a shallower depth than a ship with a narrow base?”

- b. Provide learners in mixed groups with different objects (e.g., metal, wood, plastic) to immerse in water. Have them observe which objects float and which sink and then verify the law of floatation (see Experiment 2). Learners should be encouraged to lay out their workings clearly. More able learners could be instructed to help less able learners with their calculations.
- c. Taking into consideration GESI, SEL, National values and other cross-cutting issues, assign roles such as group leader, recorder, and presenter to ensure active participation and development of leadership skills.

## KEY ASSESSMENT

**Level 1:** State the law of floatation

**Level 2:** Explain how the law of floatation applies to the design of submarines.

**Level 3:**

1. Calculate the upthrust acting on a 2cm x 2cm x 2cm cube with a weight of 0.05N. Will this cube sink, or float? If the latter, at what depth will it reach equilibrium?
2. John, a student, conducted an experiment using different objects and fluids to understand the principles of upthrust and floatation. He used a block of wood, a metal cube, and a plastic ball and placed them in a container filled with water and oil. He observed the following:
  - a) The wooden block floated on both water and oil.
  - b) The metal cube sank in both water and oil.
  - c) The plastic ball floated in water but was partially submerged in oil.

**Hint**

The recommended mode of assessment for week 16 is **case study**. Use the level 3 question 2 as a sample question.

**Section 5 review**

The section focused on electrical energy which is derived from the movement of electric charges through a conductor and is quantified in joules or kilowatt-hours. Electrical power, measured in watts, indicates the rate at which this energy is transferred within a circuit. Understanding these concepts is vital for the effective design and management of electrical systems, improving energy efficiency, and ensuring safety. Accurate calculations of power prevent overloading and reduce hazards in various electrical applications.

**ADDITIONAL READING**

Follow link or scan the QR code below to watch a video on how to build prototype of ship, boat, canoes.

<https://www.youtube.com/watch?v=CQ0qxrcHPto>

**MARKING SCHEME FOR THE CASE STUDY ASSESSMENT TASK**

- a. Wooden block: because the upthrust acting on the block is equal to its weight in both fluids. (2 marks)
- b. Metal Cube: because its density is greater than that of both fluids. (2 marks)
- c. Plastic Ball: The plastic ball floats in water but is partially submerged in oil. (2 marks)
- d. This occurs because the ball's density is less than that of water, resulting in enough upthrust to keep it afloat. (2 marks)

# SECTION 6: ELECTRONICS

## Strand: Vigour behind life

### Sub-strand: Consumer electronics

**Content standard:** Demonstrate knowledge and recognition of selected electronic components and their uses in household electronic devices.

**Learning outcome:** Apply the knowledge of doping to explain the formation and behaviour of a P- N junction diode.

#### Hint



Remind learners of **Mid-semester examination** in Week 18. Refer to the Appendix F for more sample task and the Table of Specification

## INTRODUCTION AND SECTION SUMMARY

Designing a phone charger using circuits including LEDs and diodes will bring one closer to practical electronics. One is exposed to this kind of hands-on project so that he or she gets to understand how components such as LEDs and diodes control the current and voltage, assuring efficient delivery of power. Another principle that will be introduced is ‘doping’ in semiconductors, meaning the addition of impurities to enhance electrical properties. Doping is important because it allows one to construct the main elements of modern electronic gadgets, such as diodes and transistors; it also shows that minute changes at an atomic level can bring huge steps forward in the pursuit of electronics.

*The weeks covered by the section are:*

*Week 17: Explain the principle of ‘doping’ behaviour in relation to semiconductors*

*Week 18: Perform experiments using circuits containing LEDs and diodes to build phone chargers.*

*Week 19: Perform experiments using circuits containing LEDs and diodes to build phone chargers.*

## SUMMARY OF PEDAGOGICAL EXEMPLARS

This pedagogical approach integrates Talk-for-Learning and Experiential Learning, focusing on GESI, SEL, and national values. First, learners are introduced to an overview

of basic electrical safety rules; in pairs, they discuss the reasons why such rules are important. Then, in mixed groups, they watch videos of building phone charger circuits using LEDs and diodes. They build these circuits using the provided materials, starting with the simplest one. There are specific interventions for struggling learners, while advanced learners work on extension activities. The instructor guides the discussions regarding conductors, semi-conductors, and insulators and how doping is done on semiconductors, followed by relevant experiments to sort materials into conductors and insulators and illustrate doping effects using simple circuits. Learners' roles, such as being the leader or secretary of a group, make the activity inclusive and help learners work on 21<sup>st</sup> Century competencies.

## ASSESSMENT SUMMARY

The assessment delves into learners' understanding and application of concepts in practice to build on phone chargers using doped semiconductor materials, delocalised practical skills and procedures for safety. Physical assessment: Safety demonstration in assembling circuits with LEDs and diodes. Group work and group report: Evaluate active involvement, teamwork, and integration of cross-cutting issues such as GESI and SEL. Conceptual understanding will be measured through discussions on doping and semiconductor materials. Experiential learning activities will include the classification of materials and demonstration of the doping process. The learners will be evaluated in terms of response to the given scaffolding and support, and the design of the program enables the monitoring of progress and the ability to provide specific feedback. This multifaceted approach will ensure a rounded understanding of scientific principles and practical skills, including the opportunity for extensiveness and inclusiveness devoid of any stereotypes. Teachers may, therefore, refer to the Teacher Assessment Manual and Toolkits, TAMT (NaCCA, MoE, 2003) to learn the way forward regarding the effective use of diverse assessment strategies.

**WEEK 17**

**Learning Indicator:** Explain the principle of 'doping' behaviour in relation to semiconductors

## **FOCAL AREA: PRINCIPLE OF DOPING BEHAVIOUR ABOUT SEMICONDUCTORS**

### **Classification of Solid Materials into Conductors, Insulators, and Semiconductors**

Solid materials can be classified based on their electrical conductivity into conductors, insulators, and semiconductors.

#### **Electrical Conductors**

Conductors are materials that allow flow of electric current. They have many free electrons that can move easily throughout the material. Metals such as Copper, Aluminium, and Silver are typical conductors. The atomic structure of conductors includes a sea of delocalised electrons that move freely, facilitating electrical conductivity.

#### **Insulators**

Insulators are materials that do not conduct electric current under normal conditions. Their electrons are tightly bound to their atoms, making it difficult for them to move. Common insulators include materials like rubber, glass, and ceramics. These materials have a high resistance to the flow of electric current due to their atomic structure, which lacks free charge carriers.

#### **Semiconductors**

Semiconductors have electrical properties that are different from those of conductors and insulators. They can conduct electricity under certain conditions, such as when doped with impurities or exposed to light or heat. The most common semiconductor material is Silicon, although Germanium and other compound semiconductors like Gallium Arsenide are also used. In their pure form, semiconductors have a crystalline structure with a moderate band gap which can be manipulated to control their conductivity.

For more in-depth explanation of band gap, valance band and conduction band this video is very helpful (start at minute 4 for the specific explanation):

<https://youtu.be/AF8d72Ma41M?si=UQDZ7wcAn67zDLcl>



## Experiment 17.1: experiment on electrical conductivity.

**Aim:** Classify materials based on their electrical conductivity.

**Apparatus:** Multimeter or conductivity tester, various solid materials (e.g., Copper wire, Aluminium foil, rubber, plastic, Silicon wafer), battery, connecting wires

### Procedure

1. Have learners predict whether each material will be a conductor, insulator, or semiconductor.
2. Connect the battery, multimeter, and a piece of the material in a circuit.
3. Measure the resistance or conductivity of each material using the multimeter.
4. Record the results.

### Classification

1. Materials with high conductivity (low resistance) are conductors.
2. Materials with low conductivity (high resistance) are insulators.
3. Materials with intermediate conductivity are semiconductors.

### Meaning of Doping

Doping intentionally introduces impurities into a pure semiconductor material to modify its electrical properties. This process is essential for controlling the behaviour of semiconductors and is a fundamental aspect of semiconductor device fabrication.

### Types of Doping

There are two main types of doping

**N-type doping involves adding impurities with** more valence electrons than the semiconductor material. For example, adding Phosphorus (which has five valence electrons) to Silicon (which has four valence electrons) creates extra free electrons, resulting in a negatively charged (n-type) semiconductor.

#### N-type Semiconductor

Formed by adding donor impurities.

Electrons are the majority carriers, and holes are the minority carriers.

Conductivity increases due to the addition of free electrons.

**P-type doping involves adding impurities with** fewer valence electrons than semiconductor material. For example, adding Boron (which has three valence electrons)

to Silicon creates “holes” or positive charge carriers, resulting in a positively charged (p-type) semiconductor.

### P-type Semiconductor

Formed by adding acceptor impurities.

Holes are the majority carriers, and electrons are the minority carriers.

Conductivity increases due to the creation of holes that act as positive charge carriers.

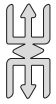

#### Note

Holes themselves are not carrying the charge, it just looks like they are. It is still the electrons themselves that are moving and we track the position of the empty space they leave behind.

### Effects of Doping

Doping alters the semiconductor’s electrical conductivity. In n-type semiconductors, the added electrons increase conductivity by providing more charge carriers. In p-type semiconductors, the holes created by the lack of electrons act as positive charge carriers, increasing conductivity. The ability to control the type and concentration of charge carriers is crucial for creating various semiconductor devices.

1. It increases the performance of semiconductor devices.
2. The effects of doping include an increase in hole mobility and a decrease in the threshold voltage, making the devices more responsive and improving their electrical properties.
3. Doping affects the electrical properties of the semiconductor by adding impurities in the form of atoms of different atoms.
4. Doping elements into silicon alters its conductive characteristics.

For more in-depth explanation of doping this video is very helpful (start at minute 6 for the specific explanation):

<https://youtu.be/AF8d72Ma41M?si=UQDZ7wcAn67zDLcl>



## Experiment 17.2: Experiment with how a diode works in a simple circuit.

**Aim:** Demonstrate how a diode works in a simple circuit.

**Apparatus:** Breadboard, diode, resistor (e.g., 1 K $\Omega$ ), LED, power supply.

### Procedure:

1. Insert the power supply (battery) into the breadboard. Connect the positive terminal to the positive rail and the negative terminal to the negative rail.
2. Place the diode on the breadboard, ensuring the anode (positive side) is connected to the positive rail and the cathode (negative side) to the negative rail.
3. Connect one end of the resistor to the diode's cathode and the other end to an empty row on the breadboard.
4. Connect the LED's longer leg (anode) to the same row as the resistor's free end. Connect the shorter leg (cathode) to the negative rail.
5. Ensure all connections are secure, then switch on the power supply. The LED should light up, indicating that current is flowing through the diode and resistor.
6. Place the multimeter probes across the diode (anode and cathode) to measure the voltage drop.
7. Switch the multimeter to the current measurement mode to measure the current flowing through the circuit.

### Observation

Ask learners to observe the LED lighting up only when the diode is correctly oriented, demonstrating the unidirectional flow of current.

Discuss why the LED does not light up if the diode is reversed (no current flow).

Discuss why the LED does not light up when the applied Voltage is very low, there must be a minimum threshold Voltage applied.

### Measurement Analysis

Analyse the voltage drop across the diode, typically around 0.7 V for silicon diodes.

Discuss the importance of using a resistor to limit current and protect the LED.

Measure the exact threshold voltage for the diode used, compare this to its quoted values and discuss the discrepancies.

## Applications of Doping to the behaviours of P-N Junction diode formation in consumer electronics

The p-n junction diode is a fundamental building block of many electronic devices. It is formed by joining p-type and n-type semiconductor materials, creating a junction with unique electrical properties.

### Formation of P-N Junction

When p-type and n-type materials are joined, electrons from the n-type region diffuse into the p-type region and recombine with holes. This diffusion creates a depletion region around the junction where no free charge carriers exist. An electric field is established across the depletion region, forming a potential barrier.

**Forward and Reverse Bias:** The behaviour of a p-n junction diode depends on the direction of the applied voltage:

**Forward Bias:** When a positive voltage is applied to the p-type material and a negative voltage to the n-type material, the potential barrier is reduced, allowing current to flow across the junction. This condition is known as forward bias and enables the diode to conduct electricity.

**Reverse Bias:** When a negative voltage is applied to the p-type material and a positive voltage to the n-type material, the potential barrier is increased, preventing current flow. This condition is known as reverse bias, and the diode acts as an insulator.

### Experiment 17.3: Experiment on Simple P-N Junction

**Aim:** Create a Simple PN Junction

**Apparatus:** N-type Silicon wafers, P-type Silicon wafers, LEDs (preferably of different colours for distinction), breadboard, multimeter, power supply (5V DC recommended), connecting wires, resistors (220 Ohms and 1k Ohms), diodes, tweezers and safety equipment (gloves, goggles)

#### Procedure

1. Place an N-type silicon wafer and a P-type silicon wafer adjacent to each other on the breadboard, creating a PN junction.
2. Connect an LED in series with a 1k Ohm resistor across the P-N junction.
3. Connect the positive terminal of the power supply to the P-type wafer and the negative terminal to the N-type wafer.
4. Observe if the LED lights up, indicating current flow across the P-N junction.

## Reverse Biasing

1. Reverse the connections, connecting the positive terminal to the N-type wafer and the negative terminal to the P-type wafer.
2. Observe if the LED lights up or if there are any changes in brightness.

## Record Observations

Note the behaviour of the LED in both forward and reverse bias conditions for the P-N junction.

Discuss the role of the depletion region and how it affects current flow.

For more in depth explanation of depletion region this video is very helpful (start at minute 7.50 for the specific explanation):

<https://youtu.be/AF8d72Ma41M?si=UQDZ7wcAn67zDLcl>



## Applications of P-N junction diodes in Consumer Electronics

1. Rectifiers: Diodes convert alternating current (AC) to direct current (DC) in power supplies.
2. Switching Devices: Diodes are used in digital circuits as switches, controlling current flow in response to input signals.
3. Light-emitting diodes (LEDs): In LEDs, the recombination of electrons and holes at the p-n junction produces light, making them widely used in display and lighting applications.
4. Photodetectors: Diodes can be used to detect light, converting it into an electrical signal for use in cameras, solar cells, and other light-sensing devices

### Experiment 17.4

**Aim:** To demonstrate the concept of semiconductor doping and its effect on electrical conductivity.

**Apparatus:** Two silicon wafers (one pure and one doped), multimeter, power supply (low voltage), wires with alligator clips, light bulb (small, low wattage)

#### Procedure:

- a. Connect the pure silicon wafer to the power supply using wires. Measure its resistance using the multimeter. Observe the light bulb's brightness (dim or off).
- b. Repeat the same setup with the doped silicon wafer. Measure its resistance and observe the light bulb (brighter).

**Explanation:** Doping introduces impurities into silicon, increasing its electrical conductivity by adding free charge carriers.

### Learning Task

1. Explain the doping of semiconductors.
2. Classify materials into insulators, conductors and semi-conductors based on electrical conductivity.
3. Demonstrate how a diode works in a simple circuit.

## PEDAGOGICAL EXEMPLARS

### 1. Talk for Learning

- a. Considering GESI, SEL, National values and other cross-cutting issues, put learners in mixed groups/pairs.
- b. Engage learners in discussing conductors, semi-conductors and insulators and their characteristics.
- c. Guide learners in a discussion to explain doping, highlighting key terms such as impurities, electron donors, and electron acceptors.
- d. Let learners in their groups explore how doping with specific impurities can create excess electrons (N-type) or electron holes (P-type) in the semiconductor material.
- e. Provide scaffolding support for learners who may face challenges and assign roles such as group leader and secretary to group members. This approach promotes 21<sup>st</sup>-century skills and national core values while also considering cross-cutting issues such as Gender Equality and Social Inclusion (GESI) and Social and Emotional Learning (SEL)

### 2. Experiential Learning

- a. Considering GESI, SEL, National values and other cross-cutting issues, put learners in mixed groups.
- b. Provide learners with materials such as (Copper wire, Aluminium foil, rubber, plastic, Silicon wafer, stones, glass, etc.), batteries, and connecting wires and guide them to classify them into conductors, insulators, and semiconductors through experiments on their electrical conductivity.
- c. Task learners in their mixed groups to experiment with simple circuit setups or semiconductor models to explain semiconductor doping. Using materials like

Silicon, for instance, LEDs can show the behaviour of N-type and P-type semiconductors.

- d. Guide learners in mixed groups to build basic circuits using doped semiconductor materials (diodes) to demonstrate their functionality in electronic circuits.
- e. Provide scaffolding support for learners who may face challenges and assign roles such as group leader and secretary to group members. This approach promotes 21<sup>st</sup>-century skills and national core values while also considering cross-cutting issues such as Gender Equality and Social Inclusion (GESI) and Social and Emotional Learning (SEL).

## KEY ASSESSMENT

**Level 1:** identify at least two examples of each of the following materials:

- a. Insulators
- b. semiconductors
- c. conductors

**Level 2:** Explain the doping of semiconductors as used in electronics

**Level 3:** Classify materials into insulators, conductors and semi-conductors based on their electrical conductivity using laboratory experiments.

**Level 4:** Demonstrate how a diode works in a simple circuit.

### Hint



The recommended mode of assessment for week 17 is **checklist**. Use the level 4 question as a sample question.

# WEEKS 18 & 19

**Learning Indicator:** Perform experiments using circuits containing LEDs and diodes to build phone chargers.

## FOCAL AREA: EXPERIMENTING WITH LED AND DIODE CIRCUITS TO BUILD PHONE CHARGERS

### Electronic Components for Building Phone Chargers

#### 1. Diodes

*Function:* Allow current to flow in one direction, preventing backflow, which can damage circuits. Examples include rectifier diodes, Zener diodes for voltage regulation, and light-emitting diodes (LEDs).

#### 2. Light-emitting Diodes (LEDs)

*Function:* Indicate the charger's status (e.g., power on/off, charging).

*Selection:* Choose LEDs based on brightness, colour, and power rating.

#### 3. Resistors

*Function:* Control current flow and prevent damage to components.

NB: Choose based on required resistance and power dissipation.

#### 4. Capacitors

*Function:* Store and release electrical energy, smoothing out fluctuations.

#### 5. Inductors

*Function:* Store energy in a magnetic field, which direct current (DC-DC) converters use to step up or down voltage.

#### 6. Transformers

*Function:* Step down alternating current (AC) voltage from mains to a lower voltage suitable for the charger.

*Specification:* Choose based on input and output voltage and power rating.

#### 7. Voltage Regulators

*Function:* Provide a stable output voltage regardless of variations in input voltage.

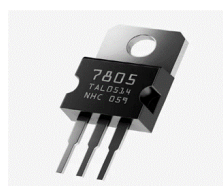

**Fig.18.1:** Picture of voltage regulator

**8. USB Connectors**

*Function:* Interface between the charger and the phone.

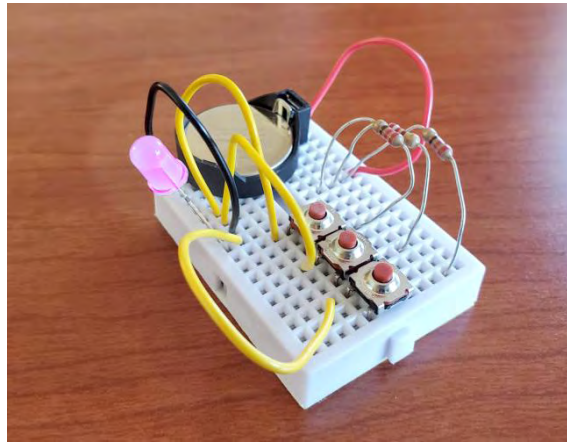
**9. Breadboards: For prototyping and testing circuits.**

**Fig 18.2:** Diagram of breadboard circuit

**10. Enclosure/Case**

*Function:* Protect the components and ensure safe handling. They are usually non-conductive materials like plastic.

## Steps Involved in Building a Phone Charger

1. Design the Circuit: Plan the circuit layout, including the placement of components such as the voltage regulator, capacitors, diodes, and connectors.
2. Gather Components: Collect all the necessary components listed above.
3. Assemble the Circuit
  - a. Connect the input of the voltage regulator to the DC power source.
  - b. Add a capacitor (typically  $0.33\ \mu\text{F}$ ) across the input terminals to filter out noise.
  - c. Connect the voltage regulator output to the USB connector's VCC pin.
  - d. Add another capacitor (typically  $0.1\ \mu\text{F}$ ) across the output terminals for stability.
4. Rectification (if using AC source)
  - a. Use rectifier diodes to convert AC to DC.
  - b. Connect the rectified output to the voltage regulator's input.
5. LED Indicators: Connect an LED with a current-limiting resistor to indicate power status.
6. Connections: Ensure all ground connections are properly made and common to all components.

7. Test the Circuit:
  - a. Before finalising, test the circuit on a breadboard.
  - b. Measure the output voltage with a multimeter to ensure it matches the phone's requirements **NB: a home-made charger should never be used to charge a personal or work device as this will likely cause damage and invalidate any product warranty.**
8. Finalise and Solder the Circuit
  - a. Once tested and verified, solder the components onto a printed circuit board (PCB).
  - b. Ensure all connections are secure and check for any short circuits.
9. Enclosure:
  - a. Place the circuit in a suitable enclosure for protection.
  - b. Ensure the enclosure has openings for the USB connectors and power input.

## Safety Precautions in Building Phone Chargers

Safety is crucial when working with electronic circuits to prevent accidents, damage to components, or injury. Some important safety precautions:

1. Ensure your workspace is clean, dry, and well-lit.
2. Use a non-conductive surface to work on, such as an anti-static mat.
3. Avoid touching electronic components with bare hands; use anti-static wrist straps to prevent static discharge.
4. Use insulated tools to prevent accidental shorts.
5. Ensure soldering irons are in good condition and use them in well-ventilated areas to avoid inhaling fumes.
6. Always disconnect the power source before making adjustments or modifications to the circuit.
7. Double-check all connections to ensure there are no short circuits.
8. Use a multimeter to check for proper continuity and correct polarity.
9. Use heat sinks on voltage regulators and other components that may get hot.
10. Avoid placing heat-sensitive components close to heat sources.
11. Incorporate fuses in the circuit to protect against overcurrent situations.
12. Test the circuit with a low-power supply initially to ensure there are no faults.
13. Gradually increase the power once you are confident in the circuit's stability.
14. Ensure the final circuit is enclosed in a non-conductive, protective casing.

## Learning Task

1. Identify electronic components for build phone chargers and outline their function.
2. Describe the safety precautions required for building phone chargers.
3. Building a phone charger using circuits containing LEDs and diodes.

## PEDAGOGICAL EXEMPLARS

### 1. Talk-for learning

- a. Introduce to learners' basic electrical safety rules, emphasizing key points like working in dry areas, avoiding liquids near the workspace, using insulated tools, and double-checking connections before powering circuits.
- b. Taking into consideration GESI, SEL, National values and other cross-cutting issues, put learners in pairs.
- c. Have learners in pairs think about why each safety rule is important and share their thoughts discussions with the class.

### 2. Experiential learning

- a. Taking into consideration GESI, SEL, National values and other cross-cutting issues, put learners in mixed groups.
- b. Provide learners in their groups with videos highlighting how to build phone chargers using LEDs and diodes circuits.
- c. Provide each group with necessary materials, including LEDs, diodes, resistors, breadboards, wires, and power sources (e.g., batteries or USB adapters). Guide learners to building circuits for phone chargers. Start with simple circuits and gradually introduce complexity as learners gain confidence and understanding. Ensure learners consider safety precautions.
- d. Monitor learners' progress closely and provide targeted support to those who need it. Offer simplified explanations, additional practice opportunities, or one-on-one guidance as necessary.
- e. Incorporate scaffolding techniques such as guided questions or step-by-step instructions to assist struggling learners in completing tasks.
- f. Challenge advanced learners with extension activities or open-ended design tasks to deepen their understanding and encourage creativity.

## KEY ASSESSMENT

**Level 1:** Identify electronic components for building phone chargers.

**Level 2:** Explain electronic components for building phone chargers.

**Level 3:** Describe safety precautions in building phone chargers.

### Level 4

1. Building a phone charger using circuits containing LEDs and diodes.
2. Study the diagram carefully and use it to answer the following questions.

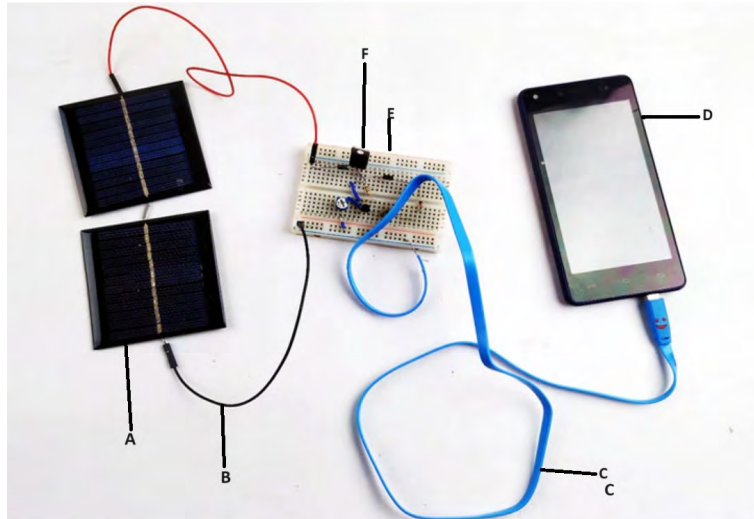

- a) Name the parts labelled A, B, D, E, F
- b) State the function of the parts labelled A and F

### Hint



- The recommended mode of assessment for week 18 is **Mid-semester examination**. Refer to the Appendix F for more sample task and the Table of Specification.
- The recommended mode of assessment for week 19 is **test of practical**. Use the level 4 question 2 as a sample question.



## Section 6 Review

In weeks 17 to 19, learners covered doping of semiconductors—that adding certain impurities in semiconductors would change electrical properties and increase conductivity. They looked at N-type and P-type doping through class discussions, visual aids, and simulations against the backdrop of application to electronic devices like diodes and transistors. Learners proceeded to the actual work on electronic circuits in the following weeks. Learners applied knowledge to build functional phone chargers in groups by making circuits with LEDs and diodes and testing them. This practical experience helped to strengthen theoretical

knowledge and further made the learners realize that semiconductors and doping were useful in real life.

## ADDITIONAL READING

Scan the QR code or follow the link to watch videos on the lessons

<p>1. video on testing for semiconductor. <a href="https://www.youtube.com/watch?v=MAIRkMSsIFw">https://www.youtube.com/watch?v=MAIRkMSsIFw</a></p>	
<p>2. video on to build a phone charger. <a href="https://www.youtube.com/watch?v=ajPkkOLsuA8">https://www.youtube.com/watch?v=ajPkkOLsuA8</a></p>	

## MARKING SCHEME FOR THE TEST OF PRACTICAL ASSESSMENT TASK

A: Solar panel

B: Connecting wires

D: Smartphone

E: Breadboard or Circuit board

F: USB charging cable

Each part is correctly spelt, such as A: Solar Panels = 1 mark

A (Solar Panel)

Converts sunlight into electrical energy to power the circuit.

F (USB Charging Cable)

Transfers electrical energy from the circuit to the smartphone, enabling charging.

Each function is correctly stated, such as A: Solar Panels - These generate electricity from sunlight = 2 marks.

## MARKING SCHEME FOR THE CHECKLIST ASSESSMENT TASK

Tick for the appropriate learner behaviour.

criteria	Comment	Yes	Partial	No
Circuit Setup	Is the circuit correctly assembled with all components, such as a battery, diode, resistor, and LED, in the correct position?			
	Is there a correct orientation of the diode, such as a resistor to the anode (positive side) of the diode.?			
Understanding of Diode Function:	Is the anode of the diode connected to the positive terminal of the battery?			
	Is the cathode of the diode connected to the negative terminal?			
Observation and Analysis:	Did the student accurately observe and explain the behaviour of the diode when it is forward and reverse-biased?			
Use of Proper Tools	Did the student use tools (e.g., multimeter, breadboard) correctly to test and analyse the circuit?			
Safety Practices:	Did the student follow all safety protocols during the demonstration such as correct voltage and avoiding short circuits)?			
Communication and Presentation:	Did the student clearly explain the setup and results using correct terminology, such as Forward and reverse Bias?			



## APPENDIX F: MID OF SEMESTER EXAMINATION

**The nature of the mid-semester examination:** The mid-semester examination will cover weeks 1-5 and consist of two sections: A and B. Section A consists of 20 objective tests, and Section B consists of tests of four essay types, two of which will be selected.

**Resource:** Printer, A4 sheets, answer booklets, stationery, timers; for e-Assessment, consider a stable internet connection, computer, or tablet, etc.

**Duration:** 60 minutes

### Sample Task

#### Section A: objective tests

In an experiment to produce a local beverage, why is it important to control the temperature during fermentation?

- a) To accelerate the boiling process
- b) To ensure the beverage has the correct acidity
- c) To maintain the growth of beneficial microorganisms
- d) To dissolve sugars faster

#### Section B: Essay type

Explain why early detection of symptoms is crucial in managing cholera outbreaks.

### Rubric

#### Section A: objective tests

Answer to sample multiple choice question = C

#### Section B: Essay type

- a) Correctly identifies key symptoms such as severe diarrhoea dehydration = 1 mark  
Specifies the importance of rehydration therapy and antibiotics in reducing severe complications and death = 2 marks.
- b) Mentions specific measures such as improving water sanitation and hygiene practices = 1 mark

Table of Specifications for Weeks 13- 17

Weeks	Focal Area(s)	Types of Questions	DoK Levels				TOTAL
			1	2	3	4	
13	Explain the concept of electrical energy and power	Objective test		1	1	-	2
		Essay	-	2	-	1	3
						-	
14	Explain the concept of electrical energy and power	Objective test	2	1	-	1	4
		Essay	-	2	1	-	3
15	Explain the principle of the transformer and its function.	Objective test	1	2	-	-	3
		Essay	-	2	1	-	3
			-	-			
16	Discuss the relationship between upthrust and the law of floatation.	Objective test	2	1	1	-	4
		Essay	1	2	-	1	4
			-			-	
17	Explain the principle of 'doping' behaviour in relation to semiconductors	Objective test	1	-	1	-	2
		Essay	1	3	-	1	4
			-	-			
		Total	8	16	4	4	30

# SECTION 7: PATHOGENIC DISEASES

## Strand: Relationships with the environment

### Sub-Strand: The human body and health

**Content Standard:** Demonstrate knowledge and understanding of pathogenic diseases of humans.

**Learning Outcome:** Analyse pathogenic diseases, their symptoms, causes, effects and preventions.

## INTRODUCTION AND SUMMARY

This section addresses the characteristics, causes, symptoms, and prevention of pathogenic diseases, particularly those most prevalent in the community. Through selected diseases, learners will be aware of the different micro-organisms and environmental causative factors. They investigate symptoms' early signs and progressions and identify the most affected demographic groups. This section also covers practical strategies for the prevention of diseases, such as hygiene practices, vaccination, and public health intervention. This strong overview enables learners to identify and fight pathogenic diseases.

*The weeks covered by the section are:*

*Week 20: Examine the characteristics, causes, symptoms and preventions of pathogenic diseases.*

*Week 21: Examine specific pathogenic diseases within the community and describe their causes, symptoms and prevention.*

## SUMMARY OF PEDAGOGICAL EXEMPLARS

This pedagogical approach emphasises research-based, collaborative, and experiential learning to deepen learners' understanding of pathogenic diseases. Learners work in diverse groups to research specific diseases using various resources, investigating causes, symptoms, and demographics. They present their findings through multimedia formats and engage in discussions to propose preventive strategies. Role-playing and empathy-building exercises address myths and promote understanding. Through visual aids and presentations, learners explore disease transmission and prevention, while guided research activities enhance their knowledge of symptoms, clinical manifestations, and

public health measures. This method ensures comprehensive learning while fostering collaboration and critical thinking.

## **ASSESSMENT SUMMARY**

The assessment evaluates learners' understanding and application of knowledge about pathogenic diseases through diverse methods. Key components include group research projects, multimedia presentations, and disease causes, symptoms, and prevention discussions. Role-playing and empathy-building exercises assess learners' ability to debunk myths and understand diverse perspectives. Visual aids and interactive presentations help gauge learners' grasp of transmission modes and hygiene practices. Collaborative activities encourage critical thinking and teamwork, while scaffolding support ensures inclusivity and effective participation. Overall, the assessment integrates theoretical knowledge with practical application and critical analysis.

Teachers can consult the Teacher Assessment Manual and Toolkits (TAMT) (NaCCA, MoE, 2003) for guidance on effectively utilising various assessment strategies.

## WEEK 20

**Learning Indicator:** *Examine the characteristics, causes, symptoms and preventions of pathogenic diseases.*

### FOCAL AREA: PATHOGENIC DISEASES

Teachers should take care to ensure that learners are not overly distressed by the delivery of this content e.g. if there is a student who has lost parents to HIV they should be warned beforehand that this topic is going to be delivered as it may be triggering for them.

#### Overview

A healthy organism is one in which all life's physical and chemical processes work harmoniously. An enormous variety of organisms exist, including some that can survive and even develop in the bodies of people or animals. If an organism can cause infection, it is an infectious agent.

Pathogens are the organism that causes the infection. Specific pathogens cause specific infections. A pathogen is an infectious agent that causes infection and illness. Diseases caused by pathogens or their toxins can be communicable or infectious. Pathogenic diseases are illnesses caused by pathogens, micro-organisms such as bacteria, viruses, fungi, or parasites that can cause disease. These pathogens invade the body, multiply, and disrupt normal bodily functions, leading to various symptoms and health issues.

A disease is defined as any deviation from health or state when the body is not at ease. It may be a sickness of the body or the mind. A disease can be as mild as a sore throat, common cold, and stomach upset or as serious as cancer. It can strike almost any body part and anybody at some stage. It can also affect a person's mental and emotional health. In this section, we will discuss diseases of the body.

#### Characteristics of Pathogenic Diseases

- 1. Causative Agents:** Pathogenic diseases are caused by micro-organisms such as bacteria, viruses, fungi, or parasites.
- 2. Transmission:** Pathogens can be transmitted in various ways, including direct contact (e.g., touching, sexual contact), indirect contact (e.g., through contaminated surfaces or objects), airborne transmission (e.g., coughing, sneezing), vector-borne transmission (e.g., through insects like mosquitoes), and through contaminated food or water.

- 3. Invasion and Multiplication:** Pathogens invade the host's body and multiply, often causing damage to tissues and organs. The extent of damage and the symptoms experienced depend on the type of pathogen and the host's immune response.
- 4. Incubation Period:** This is the time between exposure to the pathogen and the onset of symptoms. The pathogen multiplies and spreads within the host's body during this period.
- 5. Clinical Symptoms:** Pathogenic diseases often present with specific symptoms, varying widely depending on the pathogen and affected body part. Symptoms can range from mild (e.g., fever, cough) to severe (e.g., organ failure, neurological impairment).
- 6. Host Response:** The immune system's response to the pathogen can result in inflammation and other immune reactions aimed at fighting off the infection. The immune response's effectiveness can influence the disease's severity and duration.
- 7. Contagiousness:** Some pathogenic diseases are highly contagious and can easily spread from person to person, while others are less so. Contagiousness depends on the transmission mode and the pathogen's ability to survive outside the host.
- 8. Prevention and Control:** Measures to prevent and control pathogenic diseases include vaccination, proper hygiene practices (e.g., handwashing), safe food and water practices, vector control (e.g., mosquito nets), and use of personal protective equipment (e.g., masks, gloves).
- 9. Treatment:** Treatment options depend on the type of pathogen. Bacterial infections can often be treated with antibiotics, while antiviral drugs may be used for certain viral infections. Fungal and parasitic infections have their specific treatments. Supportive care (e.g., fluids, rest) is often important in managing symptoms.
- 10. Epidemiology:** The study of how pathogenic diseases spread, their impact on populations, and strategies for control and prevention is known as epidemiology. Understanding the epidemiology of pathogenic diseases helps devise public health strategies to mitigate their impact.

## Causes of Pathogenic Diseases

Pathogenic diseases are caused by various micro-organisms that can invade the body and cause illness. The main causes of pathogenic diseases include:

- 1. Bacteria:** Single-celled micro-organisms that can cause many diseases.
- 2. Viruses:** Tiny infectious agents that replicate only inside the living cells of an organism.
- 3. Fungi:** Organisms that include yeasts and moulds.

4. **Parasites:** Organisms that live on or in a host and get their food at the expense of their host.
5. **Animal Contact:** Zoonotic diseases are transmitted from animals to humans.
6. **Food and Water:** Consumption of contaminated food and water.

## Symptoms of Pathogenic Diseases

Different pathogens, including bacteria, viruses, fungi, and parasites, cause pathogenic diseases. Each type of pathogen can cause a range of symptoms depending on the specific disease and the body systems affected. Here are some common symptoms associated with each type of pathogenic disease:

Type of Infection	General Symptoms	Specific Diseases
<b>Bacterial</b>	<ol style="list-style-type: none"> <li>a. Fever</li> <li>b. Fatigue</li> <li>c. Swelling and redness at the infection site</li> <li>d. Pain (e.g., sore throat, ear pain, abdominal pain)</li> <li>e. Pus formation</li> </ol>	<ul style="list-style-type: none"> <li>- <b>Strep Throat:</b> Severe sore throat, swollen lymph nodes, fever, white patches on the tonsils.</li> <li>- <b>Urinary Tract Infection (UTI):</b> Frequent urination, burning sensation during urination, cloudy or strong-smelling urine, pelvic pain.</li> </ul>
<b>Viral</b>	<ol style="list-style-type: none"> <li>a. Fever</li> <li>b. Chills</li> <li>c. Fatigue</li> <li>d. Muscle aches</li> <li>e. Headache</li> <li>f. Cough</li> <li>g. Runny or stuffy nose.</li> </ol>	<ul style="list-style-type: none"> <li>- <b>Influenza (Flu):</b> High fever, severe body aches, fatigue, cough, sore throat, runny nose.</li> <li>- <b>COVID-19:</b> Fever, cough, shortness of breath, loss of taste or smell, fatigue, body aches.</li> </ul>
<b>Fungal</b>	<ol style="list-style-type: none"> <li>a. Itching</li> <li>b. Redness</li> <li>c. Swelling</li> <li>d. Skin lesions</li> <li>e. Scaling or peeling skin</li> </ol>	<ul style="list-style-type: none"> <li>- <b>Athlete's Foot:</b> Itching, burning, cracked, and peeling skin between the toes or on the feet.</li> <li>- <b>Ringworm:</b> Ring-shaped, red, itchy rash with a clear centre.</li> </ul>

Type of Infection	General Symptoms	Specific Diseases
<b>Parasitic</b>	<ul style="list-style-type: none"> <li>a. Diarrhoea</li> <li>b. Abdominal pain</li> <li>c. Weight loss</li> <li>d. Fatigue</li> <li>e. Itching</li> </ul>	<ul style="list-style-type: none"> <li>- <b>Giardiasis:</b> Diarrhoea, gas, greasy stools, abdominal cramps, dehydration.</li> <li>- <b>Toxoplasmosis:</b> Flu-like symptoms (in healthy individuals), severe symptoms in immunocompromised individuals (e.g., eye infections, neurological issues).</li> </ul>

## Preventing pathogenic diseases

Preventing pathogenic diseases involves a combination of personal hygiene practices, public health measures, and medical interventions. Some key strategies to prevent infections caused by bacteria, viruses, fungi, and parasites:

Strategy	Specific Measures
<b>Personal Hygiene Practices</b>	<ul style="list-style-type: none"> <li><b>a. Hand Hygiene</b> <ul style="list-style-type: none"> <li>· Wash hands frequently with soap and water, especially before eating, after using the restroom, and after coughing or sneezing.</li> <li>· Use hand sanitiser with at least 60% alcohol if soap and water are unavailable.</li> </ul> </li> <li><b>b. Respiratory Hygiene</b> <ul style="list-style-type: none"> <li>· Cover your mouth and nose with a tissue or elbow when coughing or sneezing.</li> <li>· Dispose of tissues immediately and wash hands afterwards.</li> </ul> </li> <li><b>c. Personal Cleanliness</b> <ul style="list-style-type: none"> <li>· Bathe regularly to keep skin clean and free from pathogens.</li> <li>· Maintain good oral hygiene by brushing teeth at least twice a day and flossing regularly.</li> </ul> </li> </ul>

Strategy	Specific Measures
<b>Environmental Measures</b>	<p><b>a. Sanitation</b></p> <ul style="list-style-type: none"> <li>· Ensure access to clean water and proper sewage disposal.</li> <li>· Maintain clean living environments by regularly cleaning and disinfecting surfaces, especially in kitchens and bathrooms.</li> </ul> <p><b>b. Food Safety</b></p> <ul style="list-style-type: none"> <li>· Wash fruits and vegetables thoroughly before consumption.</li> <li>· Cook meat, poultry, and seafood to safe temperatures.</li> <li>· Avoid cross-contamination by using separate cutting boards for raw meat and vegetables.</li> </ul>
<b>Vaccination</b>	<p><b>a. Routine Immunisations</b></p> <ul style="list-style-type: none"> <li>· Follow recommended vaccination schedules for children and adults to protect against diseases like measles, mumps, rubella, influenza, and human papillomavirus (HPV).</li> </ul> <p><b>b. Travel Vaccinations</b></p> <ul style="list-style-type: none"> <li>· Get vaccinated against diseases that are prevalent in travel destinations, such as yellow fever, typhoid, and hepatitis A.</li> </ul>
<b>Preventive Medications</b>	<p><b>a. Prophylactic Antibiotics</b></p> <ul style="list-style-type: none"> <li>· Use preventive antibiotics in certain situations, such as before surgery or for people exposed to certain bacterial infections like meningitis.</li> </ul> <p><b>b. Antimalarial Drugs</b></p> <ul style="list-style-type: none"> <li>· Take antimalarial medications when traveling to areas where malaria is common.</li> </ul>

Strategy	Specific Measures
<b>Healthy Lifestyle</b>	<p><b>a. Balanced Diet</b></p> <ul style="list-style-type: none"> <li>· Eat a nutritious diet to support a strong immune system.</li> </ul> <p><b>b. Regular Exercise</b></p> <ul style="list-style-type: none"> <li>· Engage in regular physical activity to maintain overall health and immune function.</li> </ul> <p><b>c. Adequate Sleep</b></p> <ul style="list-style-type: none"> <li>· Ensure sufficient sleep to help the body recover and fight off infections.</li> </ul>
<b>Public Health Measures</b>	<p><b>a. Surveillance and Monitoring</b></p> <ul style="list-style-type: none"> <li>· Monitor and track disease outbreaks to implement timely interventions.</li> </ul> <p><b>b. Quarantine and Isolation</b></p> <ul style="list-style-type: none"> <li>· Isolate infected individuals and quarantine those exposed to contagious diseases to prevent the spread.</li> </ul> <p><b>c. Education and Awareness</b></p> <ul style="list-style-type: none"> <li>· Educate the public about infection prevention and control measures through campaigns and community programs.</li> </ul>
<b>Avoiding Risky Behaviours</b>	<p><b>a. Safe Sex Practices</b></p> <ul style="list-style-type: none"> <li>· Use condoms to reduce the risk of sexually transmitted infections (STIs).</li> </ul> <p><b>b. Avoiding Sharing Personal Items</b></p> <ul style="list-style-type: none"> <li>· Do not share toothbrushes, razors, or needles that can transmit infections.</li> </ul> <p><b>c. Insect Precautions</b></p> <ul style="list-style-type: none"> <li>· Use insect repellent, wear long sleeves and pants, and use bed nets to protect against insect-borne diseases like malaria and dengue fever.</li> </ul>
<b>Animal and Insect Control</b>	<p><b>a. Vector Control</b></p> <ul style="list-style-type: none"> <li>· Implement measures to control vectors like mosquitoes and ticks, such as eliminating standing water and using insecticides.</li> </ul> <p><b>b. Pet Care</b></p> <ul style="list-style-type: none"> <li>· Keep pets healthy and vaccinated to prevent zoonotic diseases (diseases transmitted from animals to humans).</li> </ul>

**Table 20.1:** Symptoms of some common virus diseases, the causative organism, mode of transmission and preventive measures against the disease

Disease	Causative Organism	Mode of transmission	Symptoms	Prevention/ Cure
HIV	Virus	Bloodborne through blood & body fluids	<ol style="list-style-type: none"> <li>1. Flu-like symptoms during initial infection</li> <li>2. Persistent fatigue</li> <li>3. Weight loss</li> <li>4. Frequent infections</li> </ol>	<ol style="list-style-type: none"> <li>1. Safe sex practices.</li> <li>2. Community education.</li> <li>3. Robust needle and sharps procedures in medical settings.</li> <li>4. Awareness campaigns for needle users.</li> </ol>
Chicken pox	virus	Through inhalation of airborne droplets & direct contact of weeping lesions & contaminated linens	Fluid-filled vesicles rupture & scab over within one week.	<ol style="list-style-type: none"> <li>1. Provider should avoid contact if they've never had chicken pox.</li> <li>2. Vaccination now available and part of childhood immunisations. Patient isolated until all lesions crusted over and dry.</li> </ol>
Hepatitis (Jaundice)	Virus	Contaminated water	<ol style="list-style-type: none"> <li>1. Weakness</li> <li>2. Rise in body temperature</li> <li>3. Yellowing of urine, eyes and nails Loss of appetite, nausea and vomiting</li> </ol>	<ol style="list-style-type: none"> <li>1. Intake of treated water</li> <li>2. Vaccination</li> <li>3. Avoiding contact with an infected person and their articles</li> </ol>

**Table 20.2:** Symptoms of some common bacterial diseases, the causative organism, mode of transmission and preventive measures against the disease.

Disease	Causative organism	Mode of transmission	Symptoms	Prevention
Tuberculosis	Bacteria	1. Direct contact with infected person Coughing 2. Contaminated food and drinks	Difficulty in breathing, chest pain; low-grade fever, especially in the evenings over a long period; loss of weight; blood in sputum; night sweating	BCG vaccination at birth
Cholera	Bacteria	Contaminated food and water From germs present in the faeces of patients	Acute diarrhoea; vomiting; dehydration; muscle cramps	Use of clean, treated water. Vaccination. Prevention of contamination.

**Table 20.3:** Symptoms of some common protozoan (phylum or grouping of phyla which comprises the single-celled microscopic animals, which include amoebas, flagellates, ciliates, sporozoans, and many other forms) diseases, the causative organism, mode of transmission and preventive measures against the disease.

Disease	Causative organism	Mode of transmission	Symptoms	Prevention
Amoebiasis (amoebic dysentery)	Protozoa	Contaminated water and food Unwashed vegetables House flies	Abdominal pain: five to six blood and mucus-containing stools per day	Proper disposal of human excreta; Preventing food and vegetables from contamination; Drinking safe water

**Table 20.4:** Symptoms of some common Helminthic worm diseases, the causative organism, mode of transmission and preventive measures against the disease

Disease	Causative organism	Mode of transmission	Symptoms	Prevention
Filariasis (Elephantiasis)	Helminthic worm	Female <i>Culex</i> mosquito	Fever, swelling of lymph nodes, permanent swelling of feet, legs, and thighs, and accumulation of a large number of worms causing elephant leg-like swelling in the feet.	Prevention from mosquito bites: Taking preventive medicines in disease-prone areas.

### Learning Task

1. Define pathogenic diseases.
2. Explain two common characteristics of pathogenic diseases
3. Discuss how symptoms vary depending on the type of pathogen and the affected organs/systems

## PEDAGOGIES EXEMPLAR

### 1. Talk-for learning

- a. Put learners in mixed-ability groups to discuss pathogenic diseases.
- b. Task learners in their groups to discuss and present the transmission modes of pathogens (airborne, waterborne, foodborne, etc.) and the importance of hygiene and sanitation in preventing infections to the class.
- c. Guide groups to research and discuss the common characteristics of pathogenic diseases, including modes of transmission, incubation periods, infectious agents, and affected body systems.
- d. Task learners in their groups to create visual aids like posters, diagrams, or digital presentations to illustrate key concepts and findings.

## 2. Research/Collaborative Learning

- a. Put learners in their groups and provide them with resources (books, articles, online databases) to investigate the specific causes of common pathogenic diseases (e.g., influenza, malaria, tuberculosis, COVID-19). Present the findings to the class.
- b. Guide groups in compiling information on the symptoms and clinical manifestations associated with pathogenic diseases. Discuss how symptoms vary depending on the type of pathogen and affected organs/systems.
- c. Task groups will discuss and write the preventive measures such as vaccination, hand hygiene, sanitation practices, vector control, quarantine, and public health interventions for the class discussion.
- d. Allow groups to analyse historical and current disease outbreaks, exploring how public health measures have influenced disease transmission and control using a concept map for a galley walk.

## KEY ASSESSMENT

**Level 1:** Identify the three disease-causing pathogens.

**Level 2:** Explain three transmission modes of pathogenic disease.

**Level 3**

1. Discuss two preventive measures for pathogenic disease.
2. Imagine you are a team of epidemiologists tasked with investigating an outbreak of a pathogenic disease in a local community. Your goal is to thoroughly examine the disease, focusing on its characteristics, causes, symptoms, and prevention methods. As a group, you will simulate a meeting where you present your findings to a public health committee. Each member of your team will take on a specific role, such as a microbiologist, a public health official, a clinician, and a community outreach coordinator.

### Hint



The recommended mode of assessment for week 20 is **group simulation**. Use the level 3 question 2 as a sample question.

**WEEK 21**

**Learning Indicator:** *Examine specific pathogenic diseases within the community and describe their causes, symptoms and prevention.*

**FOCAL AREA: PATHOGENIC DISEASES WITHIN THE COMMUNITY**

Teachers should select a few of the diseases from the table below to focus on. The curriculum does not specify which diseases should be the focus of the learning but that learners should be able to discuss symptoms, prevention, myths and misconceptions around them. Linking to the general discussions that have been had in week 20.

This decision should be driven based upon local community need, and care should be taken to ensure that learners are not overly distressed e.g. if there is a student who has lost parents to HIV they should be warned beforehand that this topic is going to be delivered as it may be triggering for them.

Disease	Symptoms	Prevention and Cure
<p><b>Malaria</b></p> <p>A life-threatening disease caused by Plasmodium parasites. Malaria is a serious disease that spreads when a female Anopheles mosquito infected with tiny parasites bites you. When it bites, the mosquito injects malaria parasites into your bloodstream. Malaria can cause severe illness and death if not treated promptly. The parasites infect and destroy red blood cells, leading to cycles of fever and chills. The Incubation period is approximately 12 days.</p>	<ul style="list-style-type: none"> <li>● Headache, nausea and muscular pain.</li> <li>● Feeling of chilliness and shivering followed by fever, which becomes normal, along with sweating after some time.</li> <li>● The patient becomes weak and anaemic.</li> <li>● Body aches</li> <li>● Vomiting or diarrhoea.</li> <li>● Weakness</li> <li>● Abdominal pain</li> <li>● Impaired consciousness</li> <li>● Seizures</li> <li>● Abnormal behaviour</li> <li>● Anaemia</li> <li>● Respiratory distress</li> <li>● Kidney disease</li> <li>● Low blood sugar</li> <li>● Jaundice</li> <li>● Bleeding (nose, gingiva, bowels)</li> </ul>	<ul style="list-style-type: none"> <li>● Fitting the double doors and windows (with “Jali,” i.e., wire mesh) in the house to prevent mosquito entry.</li> <li>● Use of mosquito nets and mosquito repellents.</li> <li>● Water should not be allowed to collect in ditches or other open spaces to prevent mosquito breeding.</li> <li>● Sprinkling kerosene oil in ditches or other open spaces where water gets collected.</li> <li>● Antimalarial drugs to be taken</li> </ul>

Disease	Symptoms	Prevention and Cure
<p><b>Cholera</b></p> <p>It often breaks out among people in crowded areas with poor sanitary conditions. The pathogen is a comma-shaped bacterium (<i>Vibrio cholerae</i>). The disease is most common in places with poor sanitation, crowding, war, and famine. The Mode of transmission is contaminated food and water. The carrier is a housefly. The incubation period is 6 hours to 2-3 days.</p>	<ul style="list-style-type: none"> <li>● Acute diarrhoea and watery stool</li> <li>● Muscular cramps</li> <li>● Loss of minerals through urine</li> <li>● Dehydration leads to death</li> </ul>	<ul style="list-style-type: none"> <li>● Cholera vaccination should be given.</li> <li>● Electrolytes (Na, K, sugar) dissolved in water should be given to the patient to check dehydration (In the market, it is available as an ORS–oral rehydration solution).</li> <li>● Proper washing and cooking of food</li> <li>● Proper disposal of vomit and human excrement.</li> <li>● Flies should not sit on eatables and utensils.</li> </ul>

Disease	Symptoms	Prevention and Cure
<p><b>Tuberculosis (TB)</b> is a serious infectious disease caused by <i>Mycobacterium tuberculosis</i>. It mainly affects the lungs but can also spread to other body parts, such as the kidneys, spine, and brain. Tuberculosis is a major global health problem and is one of the top 10 causes of death worldwide. The bacteria spread through the air when an infected person coughs, sneezes, or speaks. Tuberculosis can be latent (inactive and not contagious) or active (symptomatic and contagious). Active Tuberculosis requires immediate medical treatment with a long course of antibiotics. The incubation period is 2-10 weeks, during which the bacteria produce a toxin, tuberculin.</p>	<ul style="list-style-type: none"> <li>● Persistent cough (lasting three weeks or longer).</li> <li>● Coughing up blood or sputum</li> <li>● Chest pain</li> <li>● Unintentional weight loss</li> <li>● Night sweats</li> <li>● Fever</li> <li>● Fatigue</li> <li>● Loss of appetite</li> </ul>	<ul style="list-style-type: none"> <li>● Vaccination: The Bacille Calmette-Guérin (BCG) vaccine provides protection against TB, especially in children.</li> <li>● Screening and Treatment: Early detection through TB screening, particularly in high-risk populations, and completing the full course of prescribed antibiotics can prevent the spread.</li> <li>● Hygiene: Wearing masks, ensuring good ventilation in living spaces, and practicing respiratory hygiene can reduce transmission.</li> <li>● Public Health Measures: Isolating infectious patients and conducting contact tracing to identify and test individuals who may have been exposed.</li> <li>● Living rooms should be airy, neat, and have clean surroundings.</li> </ul>

Disease	Symptoms	Prevention and Cure
<p><b>Hepatitis</b> is a liver inflammation most commonly caused by viral infections. Still, it can also result from other factors such as alcohol use, toxins, certain medications, and autoimmune diseases. There are several types of viral hepatitis, the most common being hepatitis A, B, C, D, and E. Each type has different modes of transmission, causes, and impacts on health.</p> <p>A. Hepatitis A (HAV) is caused by the hepatitis A virus and is transmitted through ingesting contaminated food and water.</p> <p>B. Hepatitis B (HBV) is caused by the hepatitis B virus. Transmitted through contact with infectious body fluids, such as blood, semen, and vaginal fluids. Common transmission routes include unprotected sexual contact, sharing needles, and from mother to baby during childbirth.</p>	<ul style="list-style-type: none"> <li>● Fatigue</li> <li>● Flu-like symptoms (fever, muscle or joint aches)</li> <li>● Jaundice (yellowing of the skin and eyes)</li> <li>● Dark urine</li> <li>● Pale stool</li> <li>● Abdominal pain, particularly near the liver (right upper quadrant)</li> <li>● Loss of appetite</li> <li>● Nausea and vomiting</li> </ul>	<ul style="list-style-type: none"> <li>● Vaccination</li> <li>● Effective vaccines can prevent Hepatitis A and B, and Hepatitis B vaccination can also help prevent hepatitis D.</li> <li>● There are currently no vaccines for hepatitis C and E.</li> <li>● Good Hygiene Practices</li> <li>● To prevent hepatitis A and E, ensure safe drinking water, proper sanitation, and good personal hygiene practices, such as handwashing.</li> <li>● Avoid sharing needles or personal items like razors and toothbrushes that can be contaminated with blood.</li> <li>● Ensure safe sex practices by using condoms to reduce the risk of hepatitis B and C.</li> <li>● Ensure blood products are screened for hepatitis B and C viruses.</li> <li>● Safe Food and Water: Ensure food is cooked properly and drinking water is safe, especially in areas where hepatitis A and E are common.</li> </ul>

Disease	Symptoms	Prevention and Cure
<p>C. Hepatitis C (HCV): Caused by the hepatitis C virus. Transmitted through blood-to-blood contact. Common ways include sharing needles, unsterilized blood transfusions, and, less commonly, sexual contact.</p> <p>D. Hepatitis D (HDV): This virus causes hepatitis D through contact with infectious body fluids. It occurs only in those infected with HBV, as it requires the hepatitis B virus to replicate.</p> <p>E. Hepatitis E (HEV): Transmitted through ingestion of contaminated water. Caused by the hepatitis E virus.</p>		<p>Avoid Excessive Alcohol: Limit alcohol consumption to reduce the risk of liver damage and non-viral hepatitis.</p>

Disease	Symptoms	Prevention and Cure
<p><b>Candidiasis</b> is a fungal infection caused by yeasts from the genus <b>Candida</b>, most commonly <b>Candida albicans</b>. These yeasts normally live on the skin and inside the body, in places such as the mouth, throat, gut, and vagina, without causing any problems. However, when there is an overgrowth of <b>Candida</b>, it can lead to an infection known as candidiasis. Candidiasis can occur in various body parts and is commonly known as a yeast infection. Depending on the area affected, it can have different names, such as oral thrush, vaginal yeast infection, or invasive candidiasis.</p>	<ul style="list-style-type: none"> <li>● White patches on the tongue, inner cheeks, gums, and tonsils</li> <li>● Redness or soreness in the mouth and throat</li> <li>● Difficulty swallowing or a feeling of something caught in the throat</li> <li>● Itching, burning, and irritation in the vaginal area</li> <li>● Thick, white, odourless vaginal discharge resembling cottage cheese</li> <li>● Pain during intercourse or urination</li> <li>● Fever and chills that do not improve with antibiotics</li> <li>● Can affect the blood, heart, brain, eyes, bones, and other parts of the body, leading to severe and potentially life-threatening conditions</li> </ul>	<ul style="list-style-type: none"> <li>● <b>Good Hygiene:</b> Maintain proper hygiene, especially in warm and moist body areas.</li> <li>● <b>Balanced Diet:</b> Eat a balanced diet to maintain overall health and support the immune system.</li> <li>● <b>Manage Diabetes:</b> Keep blood sugar levels under control if you have diabetes.</li> <li>● <b>Probiotics:</b> Consume probiotics to maintain a healthy balance of bacteria.</li> <li>● <b>Avoid Unnecessary Antibiotics:</b> Use antibiotics only when necessary and as prescribed by a healthcare provider.</li> <li>● <b>Wear Loose Clothing:</b> Avoid tight-fitting clothes and underwear made of synthetic materials to reduce moisture and heat buildup.</li> </ul>

Disease	Symptoms	Prevention and Cure
<p><b>Typhoid fever</b> is a serious and potentially life-threatening bacterial infection caused by <i>Salmonella typhi</i> bacteria. It is mostly transmitted through contaminated food or water and is prevalent in areas with poor sanitation and hygiene practices. This can occur due to improper handling, cooking, food storage, and inadequate sanitation facilities. Contact with an infected person can also spread the bacteria. This includes direct person-to-person transmission through faecal-oral routes or by handling objects contaminated with the bacteria.</p>	<ul style="list-style-type: none"> <li>● Fever: A high, sustained fever reaching up to 104°F (40°C).</li> <li>● Headache: Severe headache is a common symptom.</li> <li>● Weakness and Fatigue: General malaise, weakness, and fatigue are typical.</li> <li>● Abdominal Pain: Pain and discomfort in the abdomen.</li> <li>● Gastrointestinal Symptoms: Nausea, vomiting, loss of appetite, and diarrhoea or constipation. Sometimes, “rose spots” (small, red, flat spots) may appear on the abdomen and chest.</li> <li>● Enlarged Spleen and Liver: Enlargement of the spleen and liver may occur.</li> <li>● Mental Confusion: In severe cases, confusion, delirium, or a decrease in mental alertness can occur.</li> </ul>	<ul style="list-style-type: none"> <li>● Vaccination: Typhoid vaccines are available and recommended for travellers to high-risk areas or those in close contact with infected individuals. Two types of vaccines are available: an injectable polysaccharide vaccine and an oral live attenuated vaccine.</li> <li>● Safe Drinking Water: Drink only bottled or boiled water. Avoid ice cubes, as they may be made from contaminated water</li> <li>● Good Hygiene Practices: Wash hands thoroughly with soap and water, especially before eating or preparing food and after using the toilet.</li> <li>● Food Safety: Eat only thoroughly cooked food served hot. Avoid raw fruits and vegetables unless you can peel them yourself. Be cautious with street food.</li> <li>● Sanitation: Ensure proper sanitation and waste disposal practices to reduce contamination risks.</li> </ul>

Disease	Symptoms	Prevention and Cure
<p>The <b>common cold</b> is a viral infection of the upper respiratory tract, primarily affecting the nose and throat. It is caused by several viruses, with rhinoviruses being the most common culprits. It is highly contagious and spreads easily from person to person.</p> <p>The common cold is spread through respiratory droplets when an infected person coughs, sneezes, or talks. It can also be contracted by touching contaminated surfaces and then touching the nose or mouth.</p>	<ol style="list-style-type: none"> <li>1 Sneezing</li> <li>2 Runny or Stuffy Nose</li> <li>3 Sore Throat</li> <li>4 Cough</li> <li>5 Congestion</li> <li>6 Mild Headaches</li> <li>7 Mild Body Aches</li> <li>8 Low-grade Fever (rare in adults, more common in children)</li> <li>9 Fatigue</li> <li>10. Watery Eyes</li> </ol> <p>The common cold usually resolves within 7 to 10 days, but it can lead to complications, especially in vulnerable individuals.</p> <p>Complications may include:</p> <ul style="list-style-type: none"> <li>● <b>Secondary Bacterial Infections:</b> These include sinusitis, ear infections, and bronchitis, which may require antibiotics.</li> </ul>	<ul style="list-style-type: none"> <li>● <b>Hand Hygiene:</b> Wash your hands regularly with soap and water for at least 20 seconds, especially after blowing your nose, coughing, or sneezing.</li> <li>● <b>Avoid Close Contact:</b> Stay away from infected individuals and avoid sharing personal items like utensils, towels, or cups.</li> <li>● <b>Disinfect Surfaces:</b> Regularly clean and disinfect frequently touched objects and surfaces, such as doorknobs, light switches, and remote controls.</li> <li>● <b>Use Tissues:</b> When you cough or sneeze, cover your nose and mouth with a tissue or your elbow, and dispose of tissues properly.</li> <li>● <b>Healthy Lifestyle:</b> Maintain a healthy immune system by eating a balanced diet, regular exercise, adequate sleep, and managing stress.</li> </ul>

Disease	Symptoms	Prevention and Cure
<p><b>Measles</b> is a highly contagious viral infection caused by the measles virus. It primarily affects children but can occur at any age. Measles has a distinctive red rash and flu-like symptoms and can lead to serious complications. The disease is caused by the virus, which is transmitted through respiratory droplets when an infected person coughs or sneezes. It is highly contagious and can be spread from person to person through direct contact with infectious droplets or by touching surfaces contaminated with the virus and then touching the face.</p>	<ul style="list-style-type: none"> <li>● Asthma Exacerbations: Colds can trigger asthma attacks or worsen asthma symptoms.</li> <li>● Chronic Conditions: Individuals with chronic conditions like chronic obstructive pulmonary disease (COPD) or heart disease may experience worsened symptoms</li> <li>● Fever: A high fever, often over 104°F (40°C), appears about 10-12 days after exposure to the virus and lasts for 4-7 days</li> <li>● Cough: Persistent cough.</li> <li>● Runny Nose: Nasal congestion.</li> <li>● Red, Watery Eyes: Conjunctivitis.</li> <li>● Koplik's Spots: Small white spots with bluish-white centres on a red background are found inside the mouth on the inner cheek lining.</li> </ul>	
		<p>Vaccination: The MMR (measles, mumps, rubella) vaccine effectively prevents measles. It is usually given in two doses, with the first at 12-15 months of age and the second at 4-6 years of age.</p> <p>Hygiene Practices: Regular hand washing, covering the mouth and nose when coughing or sneezing, and avoiding close contact with infected individuals can help prevent the spread of the virus.</p>

Disease	Symptoms	Prevention and Cure
	<p>● <b>Rash:</b> A red, blotchy rash that usually starts on the face and behind the ears and then spreads to the rest of the body. The rash typically appears 3-5 days after the initial symptoms.</p> <p><b>Complications</b></p> <ul style="list-style-type: none"> <li>● <b>Pneumonia:</b> A common and serious complication, especially in young children and individuals with weakened immune systems</li> <li>● <b>Encephalitis:</b> Brain inflammation that can cause convulsions, hearing loss, or intellectual disability.</li> </ul> <p><b>Ear Infections:</b> Bacterial ear infections are common in children with measles.</p> <p><b>Diarrhoea:</b> Severe diarrhoea can lead to dehydration, especially in young children.</p> <p><b>Death:</b> Measles can be fatal, particularly in young children and those with compromised immune systems</p>	

## Myth and misconceptions about pathogenic diseases

### Myths and Misconceptions About Viral Pathogenic Diseases

Viral pathogenic diseases are often surrounded by myths and misconceptions, which can hinder effective prevention and treatment efforts. Some common myths and misconceptions about viral diseases and the realities behind them:

**1. Myth: All Viruses Are Highly Contagious**

**Reality:** Not all viruses spread easily from person to person. While some, like the flu or COVID-19, are highly contagious, others, such as certain strains of hepatitis, require specific conditions for transmission.

**2. Myth: Antibiotics Can Treat Viral Infections**

**Reality:** Antibiotics are effective against bacterial infections, not viral ones. Antiviral medications and vaccines treat and prevent viral infections.

**3. Myth: You Can Only Get a Virus Once**

**Reality:** Some viruses can infect a person more than once because they mutate quickly, leading to different strains. The common cold and flu are examples of such viruses.

**4. Myth: Vaccines Cause the Diseases They Are Meant to Prevent**

**Reality:** Vaccines contain weakened or inactivated parts of the virus, which cannot cause the disease. They stimulate the immune system to protect against future infections.

**5. Myth: Natural Remedies Can Cure Viral Infections**

**Reality:** While natural remedies may alleviate some symptoms, they do not cure viral infections. Proper medical treatment and antiviral medications are necessary for managing viral diseases.

**6. Myth: Viral Infections Are Always Severe**

**Reality:** The severity of viral infections varies widely. Some, like the common cold, are mild, while others, such as Ebola or HIV, can be severe or life-threatening.

**7. Myth: Only Dirty Environments Cause Viral Infections**

**Reality:** While poor hygiene and sanitation can contribute to the spread of some viruses, people can contract viral infections in various settings, including clean environments.

**8. Myth: You Can't Spread a Virus if You Don't Have Symptoms**

**Reality:** Some viruses can be transmitted by asymptomatic carriers—people who do not show symptoms but can still spread the virus to others.

### 9. **Myth: Flu Is Just a Bad Cold**

**Reality:** The flu (influenza) is a more serious disease than the common cold. It can lead to severe complications, particularly in vulnerable populations such as the elderly, young children, and those with compromised immune systems.

### 10. **Myth: Herd Immunity Can Be Achieved Without Vaccination**

**Reality:** Relying on natural infection to achieve herd immunity can result in widespread illness and death. Vaccination is a safer and more effective way to achieve herd immunity and protect the population.

### 11. **Myth: Viruses Can Only Be Transmitted During Outbreaks**

**Reality:** Viruses can be transmitted anytime, not just during outbreaks. Outbreaks increase awareness, but viruses can circulate in the community even when there is no outbreak.

## **Myths and Misconceptions About Bacterial Pathogenic Diseases**

Bacterial pathogenic diseases are often surrounded by myths and misconceptions that can lead to misunderstandings about their nature, prevention, and treatment. Some common myths and misconceptions, along with clarifications:

### 1. **Myth: All bacteria are harmful**

**Reality:** Not all bacteria are pathogenic. Many bacteria are beneficial and essential for digestion, nutrient cycling, and protecting against harmful microbes. For example, gut flora helps in digestion and synthesising certain vitamins.

### 2. **Myth: Antibiotics are effective against all types of infections**

**Reality:** Antibiotics are effective against bacterial infections, not viral infections like the common cold or influenza. Using antibiotics for viral infections can contribute to antibiotic resistance.

### 3. **Myth: Antibiotics always cure infections**

**Reality:** While antibiotics can effectively treat bacterial infections, they are not always a cure-all. Inappropriate use, incomplete courses, or resistance can lead to treatment failure.

### 4. **Myth: Bacteria can become resistant to antibiotics overnight**

**Reality:** Antibiotic resistance develops over time through genetic mutations and horizontal gene transfer. It is a gradual process influenced by overuse and misuse of antibiotics.

**5. Myth: Antibiotic resistance is solely due to overprescription**

**Reality:** While overprescribing antibiotics contributes to resistance, other factors include misuse (e.g., not completing the full course), agricultural use of antibiotics, and poor infection control practices.

**6. Myth: Vaccines are only for viral diseases**

**Reality:** Vaccines are available for some bacterial diseases as well. For example, vaccines for diphtheria, tetanus, and whooping cough are bacterial vaccines that help prevent serious diseases caused by specific bacteria.

**7. Myth: Once you have had a bacterial infection, you are immune for life**

**Reality:** Immunity to bacterial infections can be specific and may wane over time. Some bacterial diseases can reoccur or vary in their strains, potentially leading to new infections.

**8. Myth: Poor hygiene is the only cause of bacterial infections**

**Reality:** While poor hygiene can increase the risk of bacterial infections, other factors such as genetic susceptibility, underlying health conditions, and exposure to pathogens also play significant roles.

**9. Myth: Bacterial infections are always contagious**

**Reality:** Not all bacterial infections are easily transmissible. Some require close contact, while others may be transmitted through contaminated food or water.

**10. Myth: Bacterial diseases are rare and not a significant threat**

**Reality:** Bacterial diseases are still a major health concern globally. Diseases such as tuberculosis, pneumonia, and bacterial meningitis continue to impact millions of people each year.

**11. Myth: Natural remedies are as effective as antibiotics**

**Reality:** While some natural remedies may have supportive effects, they are not substitutes for antibiotics when treating serious bacterial infections. Consulting a healthcare provider for appropriate treatment is essential.

**12. Myth: Bacteria can be eliminated from the environment**

**Reality:** Bacteria are ubiquitous and cannot be entirely eradicated from the environment. The goal is to control and manage bacterial populations, especially pathogenic ones, rather than attempting complete elimination.

**13. Myth: Hand sanitisers eliminate all bacteria**

**Reality:** Hand sanitisers can reduce the number of bacteria but may not eliminate all types, especially if hands are visibly dirty or sanitiser is not used correctly. Washing with soap and water is often more effective.

**14. Myth: Antibiotics are safe to use without medical supervision**

**Reality:** Misuse or incorrect use of antibiotics can have serious consequences, including adverse effects and resistance development. It's important to use antibiotics as prescribed by a healthcare professional.

**15. Myth: A higher dose of antibiotics will always be more effective**

**Reality:** Higher doses of antibiotics do not necessarily improve efficacy and can increase the risk of side effects and resistance. Dosage should be according to medical guidance.

**Myths and misconceptions often surround fungal pathogenic diseases. Some common ones, along with clarifications****1. Myth: Fungal infections are rare and only affect immunocompromised individuals**

**Reality:** While fungal infections are more common in immunocompromised individuals, they can also affect healthy people. For example, athlete's foot and ringworm are common fungal infections that can affect anyone.

**2. Myth: Fungal infections are just like bacterial infections**

**Reality:** Fungal infections are fundamentally different from bacterial infections. They require different treatment approaches, as antifungal medications target fungi specifically, unlike antibiotics, which target bacteria.

**3. Myth: Fungal infections are always visible on the skin**

**Reality:** Fungal infections can be systemic (affecting internal organs) and not always visible on the skin. For example, invasive fungal infections like candidiasis can affect the bloodstream and organs without any external signs.

**4. Myth: You can get a fungal infection from direct contact with soil**

**Reality:** While some fungal infections, like those caused by *Histoplasma* or *Coccidioides*, can be contracted from inhaling spores in soil, direct contact is not always necessary. Many fungi are present in the environment and can infect through other means.

**5. Myth: Fungal infections are easily treated with over-the-counter medications**

**Reality:** Some fungal infections can be treated with over-the-counter antifungal creams (e.g., athlete's foot), but more severe or systemic fungal infections often require prescription medications and medical supervision.

**6. Myth: Fungal infections are contagious like viral or bacterial infections**

**Reality:** Many fungal infections are not highly contagious and require direct or prolonged exposure. For instance, athlete's foot and ringworm can be spread through

direct contact or shared surfaces, but systemic fungal infections are usually not spread person-to-person.

**7. Myth: You can get a fungal infection from wearing shoes or socks**

**Reality:** Fungal infections like athlete's foot are associated with wearing shoes or socks, particularly if damp and not breathable. However, fungal infections are not caused by wearing shoes per se but by the fungi that thrive in moist environments.

**8. Myth: Natural remedies are always effective for treating fungal infections**

**Reality:** While some natural remedies might provide relief or support, they are ineffective for treating fungal infections. Antifungal medications are often necessary, particularly for more serious or persistent infections.

**9. Myth: Fungi only cause diseases in the skin and nails**

**Reality:** Fungi can cause many infections, including systemic infections that affect internal organs and the bloodstream. For example, *Aspergillus* can cause severe lung infections and *Cryptococcus* can cause meningitis.

**10. Myth: Fungal infections are always serious and life-threatening**

**Reality:** Many fungal infections are mild and easily treatable, especially those affecting the skin and nails. Serious infections generally occur in individuals with compromised immune systems or underlying health conditions.

**11. Myth: Fungi cannot develop resistance to antifungal medications**

**Reality:** Fungi can develop resistance to antifungal medications, just as bacteria **develop** resistance to antibiotics. This is a growing concern in the treatment of certain fungal infections.

**12. Myth: Fungal infections can be prevented with good hygiene alone**

**Reality:** Good hygiene can reduce the risk of some fungal infections, particularly those affecting the skin. However, systemic fungal infections often require additional preventive measures, such as managing underlying health conditions and avoiding exposure to certain environments.

**13. Myth: If you have a fungal infection, it will always show symptoms**

**Reality:** Some fungal infections, particularly systemic ones, can be asymptomatic or have subtle symptoms, making them harder to detect without medical evaluation.

**14. Myth: All fungal infections require long-term treatment**

**Reality:** The duration of treatment for fungal infections depends on the type and severity of the infection. While some infections may require long-term treatment, many can be resolved with a shorter course of antifungal therapy.

**15. Myth: You can only get fungal infections from outdoors**

**Reality:** Fungal infections can originate from various sources, including indoor environments. Mold and yeast infections can be contracted from damp or poorly ventilated indoor areas.

**Learning task**

1. State three ways of preventing the following pathogenic disease.
  - a. Cholera (or another disease chosen by the local teacher)
  - b. Measles (or another disease chosen by the local teacher).
2. Explain any three myths and misconceptions of fungal pathogenic disease.
3. Describe the causes and symptoms of malaria (or another disease chosen by the local teacher).

**PEDAGOGICAL EXEMPLARS****1. Research/Problem-based Learning**

- a. Considering GESI, SEL, National values, and other cross-cutting issues, put learners into mixed groups and assign each group a specific pathogenic disease.
- b. Provide each group with resources such as textbooks, scientific journals, reliable websites, and local health department reports to gather information about their assigned pathogenic disease (e.g., malaria, typhoid, cholera, etc.).
- c. Encourage learners to work in groups to investigate the causes of the disease (microorganisms, environmental factors), its symptoms (early signs, progression), and the demographics of the affected population.
- d. Schedule presentation sessions where groups share their research findings with the class. Presentations can include slides, posters, videos, or interactive demonstrations.
- e. Facilitate discussions following each presentation to explore preventive measures for the disease discussed. Encourage learners to propose practical strategies applicable at individual, community, and public health levels.
- f. Provide scaffolding support for learners who may face challenges and assign roles such as group leader and secretary to group members.

**2. Collaborative Learning/Role-play**

- a. Considering GESI, SEL, National values and other cross-cutting issues, pair learners and guide them to identify common myths, misconceptions, and stereotypes associated with the assigned pathogenic disease. Encourage critical analysis and evidence-based debunking of myths.

- b. Organise debates or panel discussions on myths of the assigned pathogenic disease
- c. Facilitate activities such as role-playing scenarios or empathy-building exercises to help learners appreciate diverse perspectives and promote empathy towards affected individuals.
- d. Provide scaffolding support for learners who may face challenges and assign roles such as group leader and secretary to group members.

## KEY ASSESSMENT

**Level 1:** Identify two pathogenic diseases with their causes and symptoms.

**Level 2:** Describe preventive measures of malaria (or another disease chosen by the local teacher).

**Level 3**

1. Describe how you would clarify misconceptions about pathogenic diseases.
2. Create and present a detailed and informative poster examining specific pathogenic diseases in your community.

### Hint



The recommended mode of assessment for week 21 is **poster assessment**. Use the level 3 question 2 as a sample question.

## Section 7 Review

This section provided an in-depth exploration of pathogenic diseases, focusing on their characteristics, causes, symptoms, and prevention strategies. By examining diseases prevalent within the community, learners gained insights into the various microorganisms and environmental factors that contribute to these conditions. The progression of symptoms and the demographics most affected were thoroughly analysed. Practical prevention strategies, including hygiene practices, vaccination, and public health interventions, were discussed to equip learners with the tools to combat these diseases. Overall, this section offered a comprehensive understanding of pathogenic diseases, integrating theoretical knowledge with practical applications for effective disease management.

## ADDITIONAL REVIEW

Scan the QR code to watch video on life cycle of malaria parasite in the human body.



## MARKING SCHEME FOR THE GROUP SIMULATION ASSESSMENT TASK

Criteria	Excellent 4	Proficient (3)	Basic (2)	Needs Improvement (1)
Content Knowledge and Accuracy	<p>Stating any 4 of these:</p> <ol style="list-style-type: none"> <li>Describe the disease, including pathogen type, transmission methods, and incubation period.</li> <li>Explain the causes, including environmental, social, or biological factors.</li> <li>Accurately identifies key symptoms of the disease.</li> <li>Recommends effective prevention and control measures.</li> <li>Supports findings with credible data, research, or case studies.</li> </ol>	<p>Stating any 3 of these:</p> <ol style="list-style-type: none"> <li>Describe the disease, including pathogen type, transmission methods, and incubation period.</li> <li>Explain the causes, including environmental, social, or biological factors.</li> <li>Accurately identifies key symptoms of the disease.</li> <li>Recommends effective prevention and control measures.</li> <li>Supports findings with credible data, research, or case studies.</li> </ol>	<p>Stating any 2 of these:</p> <ol style="list-style-type: none"> <li>Describe the disease, including pathogen type, transmission methods, and incubation period.</li> <li>Explain the causes, including environmental, social, or biological factors.</li> <li>Accurately identifies key symptoms of the disease.</li> <li>Recommends effective prevention and control measures.</li> <li>Supports findings with credible data, research, or case studies.</li> </ol>	<p>Stating any 1 of these:</p> <ol style="list-style-type: none"> <li>Describe the disease, including pathogen type, transmission methods, and incubation period.</li> <li>Explain the causes, including environmental, social, or biological factors.</li> <li>Accurately identifies key symptoms of the disease.</li> <li>Recommends effective prevention and control measures.</li> <li>Supports findings with credible data, research, or case studies.</li> </ol>

Criteria	Excellent 4	Proficient (3)	Basic (2)	Needs Improvement (1)
Role-Specific Contribution	<p>Stating any 4 of these:</p> <ul style="list-style-type: none"> <li>a. Explain the pathogen's biology and laboratory findings.</li> <li>b. Discusses policies, regulations, and containment strategies.</li> <li>c. Describe clinical presentation, diagnosis, and treatment options.</li> <li>d. Proposes strategies for educating the public and promoting preventive measures.</li> </ul>	<p>Stating any 3 of these:</p> <ul style="list-style-type: none"> <li>a. Explain the pathogen's biology and laboratory findings.</li> <li>b. Discusses policies, regulations, and containment strategies.</li> <li>c. Describe clinical presentation, diagnosis, and treatment options.</li> <li>d. Proposes strategies for educating the public and promoting preventive measures.</li> </ul>	<p>Stating any 2 of these:</p> <ul style="list-style-type: none"> <li>a. Explain the pathogen's biology and laboratory findings.</li> <li>b. Discusses policies, regulations, and containment strategies.</li> <li>c. Describe clinical presentation, diagnosis, and treatment options.</li> <li>d. Proposes strategies for educating the public and promoting preventive measures.</li> </ul>	<p>Stating any 1 of these:</p> <ul style="list-style-type: none"> <li>a. Explain the pathogen's biology and laboratory findings.</li> <li>b. Discusses policies, regulations, and containment strategies.</li> <li>c. Describe clinical presentation, diagnosis, and treatment options.</li> <li>d. Proposes strategies for educating the public and promoting preventive measures.</li> </ul>
Presentation and Communication Skills	<p>Stating any 4 of these:</p> <ul style="list-style-type: none"> <li>a. Uses visual aids, charts, or demonstrations to engage the audience.</li> </ul>	<p>Stating any 4 of these:</p> <ul style="list-style-type: none"> <li>a. Uses visual aids, charts, or demonstrations to engage the audience.</li> </ul>	<p>Stating any 4 of these:</p> <ul style="list-style-type: none"> <li>a. Uses visual aids, charts, or demonstrations to engage the audience.</li> </ul>	<p>Stating any 4 of these:</p> <ul style="list-style-type: none"> <li>a. Uses visual aids, charts, or demonstrations to engage the audience.</li> </ul>

Criteria	Excellent 4	Proficient (3)	Basic (2)	Needs Improvement (1)
Critical Thinking and Problem-Solving	<p>b. Smooth transitions between speakers; each member knows their role.</p> <p>c. Employs appropriate professional and scientific terminology.</p> <p>d. Addresses questions from the audience confidently and accurately.</p>	<p>b. Smooth transitions between speakers; each member knows their role.</p> <p>c. Employs appropriate professional and scientific terminology.</p> <p>d. Addresses questions from the audience confidently and accurately.</p>	<p>b. Smooth transitions between speakers; each member knows their role.</p> <p>c. Employs appropriate professional and scientific terminology.</p> <p>d. Addresses questions from the audience confidently and accurately.</p>	<p>b. Smooth transitions between speakers; each member knows their role.</p> <p>c. Employs appropriate professional and scientific terminology.</p> <p>d. Addresses questions from the audience confidently and accurately.</p>
	<p>Stating any 4 of these:</p> <p>a. Identifies patterns and potential sources of the outbreak.</p> <p>b. Critically evaluate the effectiveness of proposed interventions.</p> <p>c. Assesses potential risks to different community groups.</p>	<p>Stating any 3 of these:</p> <p>a. Identifies patterns and potential sources of the outbreak.</p> <p>b. Critically evaluate the effectiveness of proposed interventions.</p> <p>c. Assesses potential risks to different community groups.</p>	<p>Stating any 2 of these:</p> <p>a. Identifies patterns and potential sources of the outbreak.</p> <p>b. Critically evaluate the effectiveness of proposed interventions.</p> <p>c. Assesses potential risks to different community groups.</p>	<p>Stating any 1 of these:</p> <p>a. Identifies patterns and potential sources of the outbreak.</p> <p>b. Critically evaluate the effectiveness of proposed interventions.</p> <p>c. Assesses potential risks to different community groups.</p>

Criteria	Excellent 4	Proficient (3)	Basic (2)	Needs Improvement (1)
Teamwork and Professionalism	<p>d. Proposes creative and realistic solutions to minimise future outbreaks.</p> <p>e. Adjusts strategies based on hypothetical scenarios or new information.</p>	<p>d. Proposes creative and realistic solutions to minimise future outbreaks.</p> <p>e. Adjusts strategies based on hypothetical scenarios or new information.</p>	<p>d. Proposes creative and realistic solutions to minimise future outbreaks.</p> <p>e. Adjusts strategies based on hypothetical scenarios or new information.</p>	<p>d. Proposes creative and realistic solutions to minimise future outbreaks.</p> <p>e. Adjusts strategies based on hypothetical scenarios or new information.</p>
	<p>Exhibit 4 of these Contributing to the group:</p> <p>a. equal contribution from all members.</p> <p>b. Shows respect for team members' ideas and feedback.</p> <p>c. Completes the simulation within the allocated time frame.</p> <p>d. Maintains a professional tone and appearance throughout the simulation.</p>	<p>Exhibit 3 of these Contributing to the group:</p> <p>a. equal contribution from all members.</p> <p>b. Shows respect for team members' ideas and feedback.</p> <p>c. Completes the simulation within the allocated time frame.</p> <p>d. Maintains a professional tone and appearance throughout the simulation.</p>	<p>Exhibit 2 of these Contributing to the group:</p> <p>a. equal contribution from all members.</p> <p>b. Shows respect for team members' ideas and feedback.</p> <p>c. Completes the simulation within the allocated time frame.</p> <p>d. Maintains a professional tone and appearance throughout the simulation.</p>	<p>Exhibit 1 of these Contributing to the group:</p> <p>a. equal contribution from all members.</p> <p>b. Shows respect for team members' ideas and feedback.</p> <p>c. Completes the simulation within the allocated time frame.</p> <p>d. Maintains a professional tone and appearance throughout the simulation.</p>

Criteria	Excellent 4	Proficient (3)	Basic (2)	Needs Improvement (1)
	e. Provides thoughtful feedback on group dynamics and individual contributions.	e. Provides thoughtful feedback on group dynamics and individual contributions.	e. Provides thoughtful feedback on group dynamics and individual contributions.	e. Provides thoughtful feedback on group dynamics and individual contributions.

## RUBRICS FOR THE POSTER ASSESSMENT TASK

Criteria	Excellent (4 Marks)	Very Good (3 Marks)	Good (2 Marks)	Fair (1 Mark)
Content and Accuracy	The poster depicts any 4 of these, examining specific pathogenic diseases, a. identifies and names the pathogenic disease(s). b. explains the cause, such as pathogen type and mode of transmission. c. List of symptoms associated with the disease.	The poster depicts any 4 of these, examining specific pathogenic diseases, a. identifies and names the pathogenic disease(s). b. explains the cause, such as pathogen type and mode of transmission. c. List of symptoms associated with the disease.	The poster depicts any 4 of these, examining specific pathogenic diseases, a. identifies and names the pathogenic disease(s). b. explains the cause, such as pathogen type and mode of transmission. c. List of symptoms associated with the disease.	The poster depicts any 4 of these, examining specific pathogenic diseases, a. identifies and names the pathogenic disease(s). b. explains the cause, such as pathogen type and mode of transmission. c. List of symptoms associated with the disease.

Criteria	Excellent (4 Marks)	Very Good (3 Marks)	Good (2 Marks)	Fair (1 Mark)
<b>Organization and Structure</b>	<p>d. Recommends appropriate prevention and control measures.</p> <p>The poster depicts any 4 of these;</p> <ol style="list-style-type: none"> <li>Presents information in a logical and coherent sequence.</li> <li>Uses clear headings, subheadings, and labels for sections.</li> <li>Maintains a balance between text and visual elements (charts, diagrams, images).</li> <li>Includes a firm conclusion or call to action for the community.</li> </ol>	<p>d. Recommends appropriate prevention and control measures.</p> <p>The poster depicts any 3 of these;</p> <ol style="list-style-type: none"> <li>Presents information in a logical and coherent sequence.</li> <li>Uses clear headings, subheadings, and labels for sections.</li> <li>Maintains a balance between text and visual elements (charts, diagrams, images).</li> <li>Includes a firm conclusion or call to action for the community.</li> </ol>	<p>d. Recommends appropriate prevention and control measures</p> <p>The poster depicts any 2 of these;</p> <ol style="list-style-type: none"> <li>Presents information in a logical and coherent sequence.</li> <li>Uses clear headings, subheadings, and labels for sections.</li> <li>Maintains a balance between text and visual elements (charts, diagrams, images).</li> <li>Includes a firm conclusion or call to action for the community.</li> </ol>	<p>d. Recommends appropriate prevention and control measures</p> <p>The poster depicts any 1 of these;</p> <ol style="list-style-type: none"> <li>Presents information in a logical and coherent sequence.</li> <li>Uses clear headings, subheadings, and labels for sections.</li> <li>Maintains a balance between text and visual elements (charts, diagrams, images).</li> <li>Includes a firm conclusion or call to action for the community.</li> </ol>

Criteria	Excellent (4 Marks)	Very Good (3 Marks)	Good (2 Marks)	Fair (1 Mark)
<b>Visual Appeal and Design</b>	<p>The poster shows creativity and organisation of any 4 of these:</p> <ul style="list-style-type: none"> <li>a. layout that draws attention to key points.</li> <li>b. Visuals are eye-catching,</li> <li>c. relevant, and enhance understanding of the content.</li> <li>d. Text and images are balanced and easy to follow</li> <li>e. fonts are clear, readable, and consistent</li> <li>f. Uses attractive and professional design elements</li> </ul>	<p>The poster shows creativity and organisation of any 3 of these:</p> <ul style="list-style-type: none"> <li>a. layout that draws attention to key points.</li> <li>b. Visuals are eye-catching,</li> <li>c. relevant, and enhance understanding of the content.</li> <li>d. Text and images are balanced and easy to follow</li> <li>e. fonts are clear, readable, and consistent</li> <li>f. Uses attractive and professional design elements</li> </ul>	<p>The poster shows creativity and organisation of any 2 of these:</p> <ul style="list-style-type: none"> <li>a. layout that draws attention to key points.</li> <li>b. Visuals are eye-catching,</li> <li>c. relevant, and enhance understanding of the content.</li> <li>d. Text and images are balanced and easy to follow</li> <li>e. fonts are clear, readable, and consistent</li> <li>f. Uses attractive and professional design elements</li> </ul>	<p>The poster shows creativity and organisation of any 1 of these:</p> <ul style="list-style-type: none"> <li>a. layout that draws attention to key points.</li> <li>b. Visuals are eye-catching,</li> <li>c. relevant, and enhance understanding of the content.</li> <li>d. Text and images are balanced and easy to follow</li> <li>e. fonts are clear, readable, and consistent</li> <li>f. Uses attractive and professional design elements</li> </ul>

Criteria	Excellent (4 Marks)	Very Good (3 Marks)	Good (2 Marks)	Fair (1 Mark)
<b>Communication and Presentation</b>	<p>Showing 4 of the skills e.g.</p> <ul style="list-style-type: none"> <li>a. Audible voice,</li> <li>b. Keeping eye contact</li> <li>c. Pay attention to audience</li> <li>d. Engaging the audience with interaction</li> <li>e. Use of gesture.</li> <li>f. Captures and maintains the audience's interest.</li> <li>g. Completes the presentation within the allotted time.</li> </ul>	<p>Showing 3 of the skills e.g.</p> <ul style="list-style-type: none"> <li>a. Audible voice,</li> <li>b. Keeping eye contact</li> <li>c. Pay attention to audience</li> <li>d. Engaging the audience with interaction</li> <li>e. Use of gesture.</li> <li>f. Captures and maintains the audience's interest.</li> <li>g. Completes the presentation within the allotted time..</li> </ul>	<p>Showing 2 of the skills e.g.</p> <ul style="list-style-type: none"> <li>a. Audible voice,</li> <li>b. Keeping eye contact</li> <li>c. Pay attention to audience</li> <li>d. Engaging the audience with interaction</li> <li>e. Use of gesture.</li> <li>f. Captures and maintains the audience's interest.</li> <li>g. Completes the presentation within the allotted time..</li> </ul>	<p>Showing 4 of the skills e.g.</p> <ul style="list-style-type: none"> <li>a. Audible voice,</li> <li>b. Keeping eye contact</li> <li>c. Pay attention to audience</li> <li>d. Engaging the audience with interaction</li> <li>e. Use of gesture.</li> <li>f. Captures and maintains the audience's interest.</li> <li>g. Completes the presentation within the allotted time..</li> </ul>

Criteria	Excellent (4 Marks)	Very Good (3 Marks)	Good (2 Marks)	Fair (1 Mark)
<b>Creativity and Innovation</b>	<p>The poster shows creativity and innovation of any 4 of these:</p> <ol style="list-style-type: none"> <li>Demonstrates originality in presenting the topic.</li> <li>Uses creative and innovative visual elements such as interactive charts or infographics.</li> <li>Engaging real-life examples from the community.</li> <li>Ensures the poster leaves a lasting impression on the audience.</li> </ol>	<p>The poster shows creativity and innovation of any 4 of these:</p> <ol style="list-style-type: none"> <li>Demonstrates originality in presenting the topic.</li> <li>Uses creative and innovative visual elements such as interactive charts or infographics.</li> <li>Engaging real-life examples from the community.</li> <li>Ensures the poster leaves a lasting impression on the audience.</li> </ol>	<p>The poster shows creativity and innovation of any 4 of these:</p> <ol style="list-style-type: none"> <li>Demonstrates originality in presenting the topic.</li> <li>Uses creative and innovative visual elements such as interactive charts or infographics.</li> <li>Engaging real-life examples from the community.</li> <li>Ensures the poster leaves a lasting impression on the audience.</li> </ol>	<p>The poster shows creativity and innovation of any 4 of these:</p> <ol style="list-style-type: none"> <li>Demonstrates originality in presenting the topic.</li> <li>Uses creative and innovative visual elements such as interactive charts or infographics.</li> <li>Engaging real-life examples from the community.</li> <li>Ensures the poster leaves a lasting impression on the audience.</li> </ol>

# SECTION 8: INDIGENOUS BEVERAGES

## Strand: Relationships with the environment

### Sub-Strand: Technology in local industries

**Learning outcome:** Describe the production process of indigenous beverages.

**Content standard:** Explore the production of indigenous Beverages.

#### Hint



Remind learners of End of Semester Examination in Week 24. Refer to Appendix G at the end of this section for Table of specification.

## INTRODUCTION AND SECTION SUMMARY

The production of indigenous beverages often involves traditional methods and locally sourced ingredients, reflecting a deep understanding of regional flora and cultural practices. This process typically combines biological and chemical principles, such as fermentation and extraction, to create unique flavors and nutritional profiles. For instance, in many cultures, beverages like kombucha or tepache are produced through the fermentation of sugars by specific micro-organisms, resulting in complex flavor compounds and health benefits. Understanding the science behind these processes not only highlights the ingenuity of traditional practices but also offers insights into optimizing and replicating these beverages. This experiment aims to explore the production of a local beverage, examining the roles of various ingredients and environmental factors in its creation. By integrating scientific principles with traditional techniques, this study seeks to bridge cultural heritage and modern science.

*The weeks covered by the section are:*

*Week 22: Explain the science in the production of indigenous beverage*

*Week 23: Design an experiment to produce a local beverage.*

*Week 24: Design an experiment to produce a local beverage*

## SUMMARY OF PEDAGOGICAL EXEMPLARS

This pedagogical approach integrates various learning methods to teach about indigenous beverages. It begins with learners discussing the cultural significance and scientific

principles of fermentation and distillation, creating visual aids to illustrate their findings. They then conduct laboratory experiments on distillation, receiving scaffolding support and assuming specific roles within mixed groups. A field trip to a local brewery allows them to observe and document production processes, guided by pre-prepared questions and worksheets. Back in the classroom, learners analyse their observations, present findings, and incorporate insights from expert talks on beverages like Pito and Sobolo. In project-based learning, learners design flow charts for beverage preparation, detailing ingredients and methods. Finally, they prepare their chosen beverages, following their flow charts, documenting the scientific processes involved, and receiving support as needed. This comprehensive approach fosters both theoretical understanding and practical application.

## ASSESSMENT SUMMARY

Assessment is conducted through various methods to ensure a thorough understanding of indigenous beverages. Learners are evaluated on their discussions and visual aids, which reflect their grasp of cultural significance and scientific principles. Practical skills are assessed through their laboratory experiments on distillation. During the field trip, learners' observational skills and ability to formulate questions and hypotheses are reviewed. Collaborative analysis of group presentations and observations helps gauge teamwork and understanding. In project-based learning, the accuracy of flow charts for beverage preparation and the application of scientific principles during actual beverage preparation are assessed. This multifaceted approach ensures that learners' theoretical knowledge and practical skills are both thoroughly evaluated.

Teachers can consult the Teacher Assessment Manual and Toolkits (TAMT) (NaCCA, MoE, 2003) for guidance on effectively utilising various assessment strategies.

## WEEK 22

**Learning indicator:** *Explain the science in the production of indigenous beverage*

### FOCAL AREA: THE SCIENCE INVOLVED IN THE PRODUCTION OF INDIGENOUS BEVERAGES

#### Meaning of Indigenous beverages

Indigenous beverages are traditional drinks rooted in the cultural and historical practices of local communities. These beverages are often made using locally sourced ingredients and methods passed down through generations, reflecting the unique heritage and identity of a region.

#### Characteristics of indigenous beverages

1. **Locally Sourced Ingredients:** Indigenous beverages are made from ingredients that are naturally available in the region. This can include fruits, grains, roots, herbs, and other plant materials.
2. **Traditional Preparation Methods:** The methods used to prepare these beverages are traditional and often involve fermentation, brewing, distillation, or simple extraction techniques.
3. **Cultural Significance:** These drinks often hold cultural, religious, or social importance. They are typically consumed during festivals, rituals, or communal gatherings.
4. **Nutritional and Medicinal Benefits:** Many indigenous beverages are known for their health benefits, providing essential nutrients, probiotics, or medicinal properties.

#### Indigenous beverages

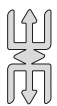

##### Note

Teachers need not learn or cover all of these, they should focus on one or two that are pertinent to the local area).

1. **Sobolo:** Sobolo is made from hibiscus leaves and infused with ginger and pineapple juices, giving it a sharp, unique taste. It is typically served chilled and pairs well with spicy meals. Some bars have created cocktails using Sobolo, making it a popular and favourite drink among Ghanaians.
2. **Brukina:** Brukina, also known as ‘deger’ or ‘nunu’ in parts of West Africa, is a fermented beverage made from cow milk and millet. A touch of sugar and salt is

added for a distinctive taste, and peanuts can be included for extra flavour. Burkina is rich in nutrients like magnesium, calcium, manganese, tryptophan, phosphorus, fibre, vitamin B, and antioxidants.

3. **Asaana:** Asaana, often called the “African Coca-Cola,” is a popular non-alcoholic caramelised corn drink made from fermented corn and caramelised sugar, with a taste like malt. Large ice cubes are added to keep it chilled.
4. **Pito:** Pito is a fermented African beverage like beer made from millet or sorghum, or a combination of both. The grains are soaked, dried, milled, mixed with water, boiled, and left to ferment. Before serving, Pito is strained and has a subtly sweet and slightly sour taste, ranging from amber to dark brown. Traditionally served in a calabash, it is often drunk from regular cups. Pito is usually bought directly from the households where it is brewed and is an important income source for rural households. It is mainly enjoyed at gatherings like marriages, naming ceremonies, and burials.
5. **Palm Wine:** Palm wine is an alcoholic drink made from the sap of various palm tree species. Tappers climb the trees to extract the sap, which is then left to ferment with airborne yeast. The extraction involves inserting a small fire into a fallen palm tree’s trunk to release the sap, which is collected in jars. The sap ferments quickly, developing an alcohol content similar to regular beer within two hours.
6. **Ginger Drink:** The ginger drink is a pure, spicy ginger beverage. Various flavourings can be added for a unique twist. It is particularly good for colds and sore throats.
7. **Lamugin:** Although like the ginger drink, Lamugin is different as it is prepared by blending ginger with other ingredients such as lemon, soaked cloves, and water.
8. **Akpeteshie:** Akpeteshie is a stronger alcoholic beverage than whiskey and is often considered Ghana’s national spirit. It is made by distilling palm wine or sugar cane and has a rich history.
9. **Mahewu:** Mahewu is a fermented maize drink that is slightly sour and non-alcoholic. It is made by fermenting maize porridge and is often consumed as a refreshing and nutritious beverage.
- 10 **Nmedaa:** Nmedaa, also known as “tiger nut milk,” is made from tiger nuts (*Cyperus esculentus*). The nuts are soaked, blended, and strained to produce a creamy, sweet milk that is sometimes flavoured with vanilla or ginger.

## Scientific processes Involved in the Production of Indigenous beverages

### 1. Fermentation

Fermentation is a key process in creating many traditional beverages. This biological mechanism converts sugars into alcohol and Carbon dioxide using micro-organisms like yeast and bacteria.

**Ethanol Fermentation:** This method is widely used to produce alcoholic beverages such as palm wine, traditional beers, and fruit-based fermented drinks. Yeasts like *Saccharomyces cerevisiae* transform glucose into ethanol and CO<sub>2</sub>.

**Lactic Acid Fermentation:** This process is utilised in making non-alcoholic fermented beverages, including traditional fermented milk drinks (such as kefir) and certain vegetable-based drinks. Lactic acid bacteria (like *Lactobacillus* species) convert sugars into lactic acid, which acts as a preservative and gives the beverage a tangy flavour.

### 2. Distillation

Distillation creates spirits from fermented beverages by heating the liquid to separate alcohol from water and other components based on their differing boiling points.

#### Experiment 1

**Aim:** To show the distillation process

**Apparatus:** Heat source (such as a hot plate), heat-resistant flask (Erlenmeyer or round-bottom), a distillation apparatus (condenser and collection flask), thermometer, rubber tubing, Ice and water, alcohol-water mixture (e.g., a small amount of rubbing alcohol diluted with water), clamps and stands, Safety goggles and gloves

#### Procedure

- i. Secure the heat-resistant flask on a stand using a clamp.
- ii. Attach the distillation condenser to the flask. Ensure the condenser is properly connected to allow the vapour to pass through and condense into the collection flask.
- iii. Connect rubber tubing to the condenser's water inlet and outlet. Place the inlet tube into a container of cold water with ice to keep the condenser cool. The outlet tube should lead to a drain or another container.
- iv. Place the thermometer in the flask, ensuring that its bulb is immersed in the liquid but not touching the bottom.

- v. Pour the alcohol-water mixture into the heat-resistant flask and note its initial temperature.
- vi. Turn on the heat source and gradually heat the mixture. Observe the temperature rise.
- vii. As the mixture heats up, the alcohol (which has a lower boiling point than water) will start to evaporate first.
- viii. The vapour will travel up into the condenser, which will cool down and condense into liquid form.
- ix. Collect the condensed liquid (distillate) in the collection flask.

### Observation

- i. Monitor the temperature closely. When the alcohol is boiling, the temperature will remain relatively steady and then start to rise again as the water begins to boil.
- ii. Collect the distillate at different temperature intervals to observe the separation of alcohol and water.

### Explanation

This hands-on activity demonstrates the principle of distillation, where a mixture is separated based on the different boiling points of its components. As the mixture heats up, the component with the lower boiling point (alcohol) evaporates first. The vapour then travels through the condenser, which cools and returns to a liquid state, separating it from the component with a higher boiling point (water).

### Safety Precautions

1. Always wear safety goggles and gloves to avoid splashes or spills.
2. Ensure the heat source is stable and does not come into direct contact with flammable materials.
3. To avoid inhaling vapours, Experiment in a well-ventilated area or under a fume hood.
4. Be cautious with the glassware and heat sources to prevent burns or breakages.

## 3. Pasteurisation

Pasteurisation involves heating beverages to a specific temperature to eliminate harmful micro-organisms without significantly altering the taste. This technique is used to prolong the shelf life of both alcoholic and non-alcoholic drinks.

## 4. Filtration

Filtration processes are used to remove solid particles, yeast, and other impurities to enhance the clarity and stability of the beverage. This can involve physical filters, and clarification might use substances like bentonite or egg whites.

## 5. Carbonation

Carbonation adds Carbon dioxide to a beverage, either naturally during fermentation or artificially. This process is commonly used to produce sparkling wines and traditional sodas.

## 6. Brewing

Brewing indigenous beverages combines traditional techniques with scientific principles, involving the transformation of raw ingredients into flavourful drinks through fermentation and other biochemical processes

### Learning Task

1. Identify some examples of indigenous beverages in Ghana
2. Explain the scientific processes involved in production of indigenous beverages.
3. Explain the distillation process using hands-on experiments in the laboratory.

## PEDAGOGICAL EXEMPLARS

### 1. Talk-for learning

- a. Guide learners in pairs to discuss some indigenous beverages and highlight their cultural significance, traditional methods, and scientific principles involved in fermentation and distillation processes.
- b. Considering GESI, SEL, National values and other cross-cutting issues, put learners in mixed groups
- c. Task learners in their group to create visual aids, such as posters, diagrams, or digital presentations, to illustrate key concepts and findings.

### 2. Experiential learning

- a. Considering GESI, SEL, National values and other cross-cutting issues, put learners in mixed groups.
- b. Guide learners in their groups to conduct laboratory experiments on the distillation process to deepen their understanding.
- c. Provide scaffolding support for learners who may face challenges and assign roles such as group leader and secretary to group members.

### 3. Field trip

- a. Plan a visit to a local industry or brewery where indigenous beverages are produced. Ensure necessary permissions, safety measures, and arrangements for observation and documentation.
- b. Encourage groups to come up with questions and hypotheses about the processes they expect to observe during the industry visit.
- c. During the visit, give learners a worksheet on what they expected to observe and question.

### 4. Collaborative Learning

- a. In the classroom, consider GESI, SEL, national values, and other cross-cutting issues, and put learners in mixed groups.
- b. Let learners in their groups review their observations, photographs, and notes during the visit and analyse the scientific principles they observed.
- c. Organise a session in which each group presents its findings, observations, and analyses to the rest of the class. Encourage multimedia presentations, diagrams, and tangible examples to enhance understanding.

## KEY ASSESSMENT

**Level 1:** Identify some examples of indigenous beverages in Ghana

**Level 2:** Explain the scientific processes involved in the production of indigenous beverages.

**Level 3**

1. Explain the distillation process using a hands-on experiment in the laboratory.
2. Plan a visit to a local industry or brewery where indigenous beverages are produced and write a field report detailing their observations.

#### Hint



The recommended mode of assessment for week 22 is **field trip**. Use the level 3 question 2 as a sample question.

**WEEK 23**

**Learning Indicator:** *Design an experiment to produce a local beverage*

## **FOCAL AREA: PRODUCTION OF INDIGENOUS BEVERAGES SUCH AS ASAANA**

**This week should be adapted by the teacher to suit the local area and most appropriate beverage.**

### **Asaana/elewonyo/liha/ekuleme drink production**

Asaana, often called the “African Coca-Cola,” is a popular non-alcoholic caramelised corn drink made from fermented corn and caramelised sugar, with a taste like malt. Large ice cubes are added to keep it chilled.

**Ingredients:** 200 grams dry corn kernels, 100 grams sugar for caramel, sugar to taste, milk (optional)

#### **Procedure**

- a. Soak corn kernels in 2 litres of water for 2 days, making sure to change the water on the second morning.
- b. Place corn kernels on a kitchen towel and then on a flat wide sieve (similar to a winnower) or a flat surface and leave covered in a dark dry place to germinate. This could take between 2-4 days.
- c. Dry the sprouted kernels in the sun for about 6 hours and then sprinkle with water and wrap tightly in old newspapers. Store in a dark, dry, and cool place for one day.
- d. Break up the kernels into smaller pieces by pulsing in a blender or a food processor. Sieve into a bowl and keep both flour and larger chunks of corn.
- e. Boil the larger, broken chunks of corn in about 1 litre of water for about 30 minutes, strain and leave to cool.
- f. Roast the flour in a pan over low to medium heat until flour is dark brown in colour.
- g. Mix strained liquid and roasted cornflour and leave overnight to slightly ferment.
- h. In a pan, make the caramel by melting sugar until pale brown to dark brown.
- i. Mix the caramel with the slightly fermented liquid and add more sugar if needed.
- j. Bottle and keep in the fridge or freezer.

## Scientific Processes Involved in Asaana/elewonyo/liha/ekuleme drink production

1. **Cleaning and soaking:** Thoroughly wash the grains to remove debris and stones and soak them in water for 48-72 hours. This causes hydration and activation of enzymes within the grains, initiating the germination process.
2. **Germination (Malting):** Covering and maintaining moisture allows the grains to sprout. This causes the enzymatic breakdown of starches into simpler sugars, which are essential for fermentation.
3. **Drying:** Drying the sprouted grains to halt the germination process. It also preserves the enzymatic activity while making the grains suitable for storage and milling.
4. **Caramelisation:** Melting and browning sugar in a pot. This thermal decomposition of sugar molecules results in complex flavours and colour changes.
5. **Dissolution:** Adding hot water to caramelised sugar creates a syrup without crystallisation.
6. **Mashing:** Mixing powdered grains with water and boiling.
7. **Boiling:** Heat the mixture for one hour. This sterilises the mixture and extracts flavours and sugars from the malted grains.
8. **Filtration:** Strain the boiled mixture through metal mesh and cheesecloth. This removes solid particles, resulting in a clear liquid.

### Learning Task

1. Identify ingredients for the preparation of asaana/elewonyo/liha/ekuleme.
2. Explain the scientific processes involved in asaana/elewonyo/liha/ekuleme. production
3. Demonstrate how asaana/elewonyo/liha/ekuleme. is produced using the necessary ingredients.

## PEDAGOGICAL EXEMPLARS

### 1. Talk-for learning

- a. Invite a resource person to give a talk on any traditional local beverages, such as asaana/elewonyo/liha/ekuleme.
- b. Encourage learners to take notes while listening or let them watch a video that highlights asaana/elewonyo/liha/ekuleme preparation.
- c. Considering GESI, SEL, National values, and other cross-cutting issues, put learners in mixed groups to discuss their documented notes and present.

## 2. Project-based learning

- a. Task learners in their groups to design a flow chart or process diagram outlining the sequential steps involved in preparing the asaana/elewonyo/liha/ekuleme. Encourage learners to include ingredient quantities, preparation methods and safety precautions in the flow chart.
- b. Schedule presentation sessions where groups showcase their flow charts, describe their experimentation process, share results, and discuss lessons learned.

## 3. Experiential Learning

- a. Considering GESI, SEL, National values and other cross-cutting issues, put learners in mixed groups.
- b. Provide learners in their groups with the necessary materials, ingredients, equipment (vessels, strainers, measuring tools), and a safe workspace to guide them to prepare their indigenous beverage.
- c. Guide learners in groups to follow their designed flow chart and prepare their chosen beverages. Encourage learners to document and discuss the scientific processes involved during the process.
- d. Provide scaffolding support for learners who may face challenges and assign roles such as group leader and secretary to group members.

## KEY ASSESSMENT

**Level 1:** Identify ingredients for the preparation of asaana/elewonyo/liha/ekuleme.

**Level 2:** Explain three scientific processes involved in asaana/elewonyo/liha/ekuleme.

**Level 3:** Demonstrate how asaana/elewonyo/liha/ekuleme is produced using the necessary ingredients and materials

### Hint



The recommended mode of assessment for week 23 is **homework**. Use the level 2 question as a sample question.

**WEEK 24**

**Learning Indicator:** *Design an experiment to produce a local beverage*

## **FOCAL AREA: PRODUCTION OF INDIGENOUS BEVERAGES SUCH AS SOBOLO**

**This week should be adapted by the teacher to suit the local area and most appropriate beverage.**

### **Sobolo (Hibiscus Tea)**

Sobolo is made from hibiscus leaves and infused with ginger and pineapple juices, giving it a sharp, unique taste. It is typically served chilled and pairs well with spicy meals. Some bars have created cocktails using Sobolo, making it a popular and favourite drink among Ghanaians.

### **Preparation of Sobolo (Hibiscus tea)**

#### **Ingredients**

1. One pineapple, one cup of dates, two cups of hibiscus, water, and sugar to taste
2. Spices of your choice: two large thumbs of ginger (peeled), fifteen grains of Selim, seven African nutmeg, two tablespoons of cloves, two dried chillies, one tablespoon of black peppercorn, one tablespoon of grains of paradise

#### **Procedure**

1. Prepping Ingredients
  - i. Clean the pineapple by soaking it in a water and vinegar for 2-3 minutes.
  - ii. While the pineapple is soaking, soak the dates in warm water until they are soft, then drain.
  - iii. Remove a few leaves from the pineapple crown and peel the pineapple.
  - iv. Cut the pineapple into chunks, removing the core.
2. Making the Drink
  - i. Blend the pineapple chunks with ginger, spices, and dates until smooth.
  - ii. In a pot, combine the pineapple leaves, skin, blended mixture, and spices with 10 cups of water. Bring to a boil without covering the pot to prevent splashing.
  - iii. Once the water reaches a boil, add the hibiscus leaves and reduce the heat to maintain a rolling boil, allowing the mixture to steep.
  - iv. Steep the mixture for at least 30 minutes, then turn off the stove.

- v. Add sugar to taste.
- vi. Allow the drink to cool to room temperature.
- vii. Strain the drink using a fine mesh strainer.
- viii. Bottle the drink and store it in the fridge.

## Scientific Processes Involved in Sobolo Production

1. **Cleaning:** Clean the pineapple by soaking it in a water and vinegar solution for 2-3 minutes. The vinegar's acetic acid kills bacteria and removes pesticides from the surface of the pineapple.
2. **Soaking:** This hydrates and softens the dates, making them easier to blend.
3. **Blending:** This process mechanically breaks the fruit and spices into a homogenous mixture, facilitating flavour extraction and nutrient release.
4. **Boiling:** The heat facilitates the extraction of flavours and beneficial compounds from the ingredients.

### Learning Task

1. Identify ingredients for the preparation of Sobolo
2. Explain the scientific processes involved in Sobo production
3. Demonstrate how Pito is produced using the necessary ingredients.

## PEDAGOGICAL EXEMPLARS

### 1. Talk-for learning

- a. Invite a resource person to give a talk on any traditional local beverages, such as Pito. Encourage learners to take notes while listening or let them watch a video that highlights Sobolo preparation.
- b. Considering GESI, SEL, National values, and other cross-cutting issues, put learners in mixed groups to discuss their documented notes and present.

### 2. Project-based learning

- a. Considering GESI, SEL, National values and other cross-cutting issues, put learners in mixed groups.
- b. Task learners in their groups to design a flow chart or process diagram outlining the sequential steps involved in preparing the Sobolo. Encourage learners to include ingredient quantities, preparation methods and safety precautions in the flow chart.

- c. Schedule presentation sessions where groups showcase their flow charts, describe their experimentation process, share results, and discuss lessons learned.

### 3. Experiential Learning

- a. Considering GESI, SEL, National values and other cross-cutting issues, put learners in mixed groups.
- b. Provide learners with the necessary materials, ingredients, equipment (vessels, strainers, measuring tools), and a safe workspace to guide them in preparing their indigenous beverage.
- c. Group learners follow their designed flow chart and prepare their chosen beverages. Encourage learners to document and discuss the scientific processes involved during the process.
- d. Provide scaffolding support for learners who may face challenges and assign roles such as group leader and secretary to group members.

## KEY ASSESSMENT

**Level 1:** Identify the ingredients for the preparation of Sobolo

**Level 2:** Explain the scientific processes involved in Sobolo production

**Level 3:** Demonstrate how Sobolo is produced using the necessary ingredients and materials.

### Hint





*The recommended mode of assessment for week 24 is **end of semester examination**. Refer to Appendix G at the end of this section for Table of specification.*

## Section 8 Review

This section provided a well-rounded approach to teaching and assessing indigenous beverage production. It effectively integrated theoretical knowledge with practical experience, fostering a deep understanding of both cultural and scientific aspects. The blend of discussion, visual aids, and laboratory experiments offered a comprehensive learning experience, while the field trip enriched learners' observations and real-world connections. Collaborative and project-based learning further enhanced understanding by encouraging teamwork and application of concepts. The assessment methods were robust, evaluating both theoretical knowledge and practical skills through diverse activities. Overall, this approach ensured that learners gained a holistic grasp of indigenous beverages, their production processes, and the underlying scientific principles, preparing them for both academic and practical applications.

## ADDITIONAL REVIEW

Scan the QR code or follow the link to watch videos on the lessons

1. Video on sobolo preparation <a href="https://www.youtube.com/watch?v=dyQzqIxdeOQ">https://www.youtube.com/watch?v=dyQzqIxdeOQ</a>	
2. Video on Pito preparation. <a href="https://www.youtube.com/watch?v=Y7jFwLx_Lpg">https://www.youtube.com/watch?v=Y7jFwLx_Lpg</a>	
3. Video on Asaana/elewonyo/liha/ekuleme drink production. <a href="https://www.youtube.com/watch?v=KQMZ1zIwC5w">https://www.youtube.com/watch?v=KQMZ1zIwC5w</a>	

## MARKING SCHEME FOR THE FIELD TRIP ASSESSMENT TASK

- a. Provide an overview of the industry/brewery visited. (2 marks)
- b. Brief industry history and its role in producing indigenous beverages. (2 marks)
- c. Purpose of the visit and objectives of the report. (2 marks)
- d. Detailed description of the primary ingredients used in the beverages (e.g., grains, fruits, herbs). (2 marks)
- e. Explanation of any traditional methods employed in the production process, such as fermentation or distillation. (2 marks)
- f. Observation of modern technology or methods integrated into production. (2 marks)
- g. Description of the measures taken to ensure the quality and safety of the beverages (2 marks).
- h. Exploration of the cultural importance of beverages in the local community. (2 marks)
- i. Discuss the industry's economic impact on the region, including employment and contribution to local markets. (2 marks)
- j. Overview of the challenges faced by the industry, such as competition with mass-produced beverages, regulatory hurdles, and sustainability concerns. (2 marks)
- k. Discussion on how the industry is addressing these challenges. (2 marks)

- l.** Examination of the sustainability practices employed by the industry, such as sourcing raw materials, waste management, and energy use. (2 marks)
- m.** Consider the environmental impact of the production process. (2 marks)
- n.** Recap of the key observations and learnings from the visit. (2 marks)
- o.** Final thoughts on supporting and preserving indigenous beverage production. (2 marks)
- p.** Photographs of the visit (2 marks)

## MARKING SCHEME FOR THE HOMEWORK ASSESSMENT TASK

- a.** Identification of processes such as Fermentation, Enzymatic Breakdown, Pasteurization, pH Adjustment and Acidity, etc. = Any 3 for 3 marks
- b.** Clear explanation of the process, such as

**Fermentation:** involves the breakdown of carbohydrates (usually sugars) into alcohol or acids using microorganisms such as yeast or bacteria under anaerobic conditions. = 2 marks

**Enzymatic Breakdown:** involves enzymatic actions that break down complex carbohydrates into simpler sugars that can be fermented



## APPENDIX G: END OF SEMESTER EXAMINATION

**The nature of the end of semester examination:** The end of semester examination will cover weeks 13- 24 and consist of three papers: 1, 2, and 3. Paper 1 consists of 50 objective tests, paper 2 consists of five essay types, three of which will be selected, and paper 3 consists of four compulsory practical tests, all of which learners are to answer.

**Resource:** Printer, A4 sheets, answer booklets, stationery, timers; for e-Assessment, consider a stable internet connection, computer, tablet, etc.

**Duration:** 120 minutes

### Sample task

**Paper 1:** This section consists of 50 objective test items. Answer all questions. Each question carries 1 mark, for a total score of 50 marks.

What role does LED play when constructing a phone charger?

- A) To increase the brightness of the display.
- B) To prevent the charger from overheating.
- C) To regulate the voltage supplied to the phone.
- D) To indicate that the charger is receiving power and functioning correctly.

**Paper 2:** This paper consists of five (5) questions, answer only three (3). Each question carries fifteen (15) marks making the total score 45 marks.

Explain the principle of ‘doping’ behaviour about semiconductors.

**Paper 3:** This paper consists of two (2) compulsory tests of practical questions, all of which must be answered for a total of forty (40) marks.

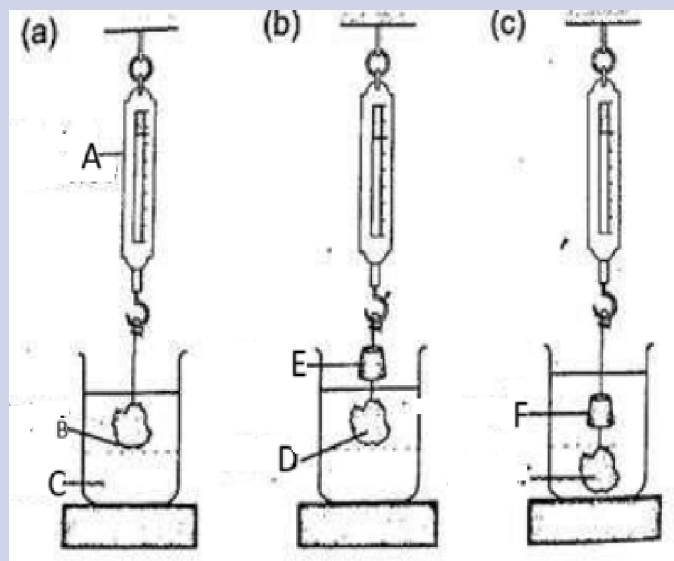

- i. What is the reading of the spring balance in air (A)?

- ii. What is the spring balance reading when the solid is partially submerged in water (E)?
- iii. What is the spring balance reading when the solid is fully submerged in water (F)?
- iv. Calculate the apparent loss in weight of the solid when it is fully submerged.
- v. Determining the solid object's density using the apparent weight loss.
- vi. Explain why the solid loses weight when submerged in water.

### Rubric/marking scheme

#### Paper 1: Objective test

Answer to sample objective question = C

Award 1 mark for each correct objective answer

#### Paper 2: Essay test

- i) stating the definition: Intrinsic semiconductors are pure semiconductors without any significant impurities, and doping involves intentionally introducing impurities, known as dopants, into the intrinsic semiconductor to increase its conductivity. = 4 marks
- ii) stating the types of Doping such as N-Type Doping 1 mark

Stating the effect on Conductivity, such as the introduction of dopants increases the number of free charge carriers (electrons in N-type and holes in P-type) =2 marks

#### Paper 3: Test of practical

- a) What is the reading of the spring balance in air (A)?

The reading of the spring balance in air represents the weight of the solid object (B) when it is not submerged in water. Let's denote this reading as  $W(\text{air})$ .

- b) What is the spring balance reading when the solid is partially submerged in water (E)?

The reading of the spring balance when the solid is partially submerged will be less than  $W_{\text{air}}$ . Let's denote this as  $W(\text{partial})$ . This value is not typically used to calculate density but helps understand buoyancy effects.

**Table of Specification for Week 13–24**

Weeks	Focal Area(s)	Type of Questions	DoK Levels				Total
			1	2	3	4	
13	Explain the concept of electrical energy and power	Objective test	1		-	-	2
		Essay	-	-	-	-	1
		Test of Practical	1	1	-	-	1
14	Explain the concept of electrical energy and power	Objective test	1	3		-	6
		Essay	1	-		-	1
		Test of Practical	1	1	1	-	1
15	Explain the principle of the transformer and its function.	Objective test	1	1	1		3
		Essay	1	1	-	-	1
		Test of Practical	1	-	1		2
16	Discuss the relationship between upthrust and the law of floatation.	Objective test	1	1	1		5
		Essay	1	1		-	1
		Test of Practical	1	1	1		2
17	Explain the principle of ‘doping’ behaviour in relation to semiconductors	Objective test	1	1	-		4
		Essay	-	-	-	-	-
		Practical	-	1	-	-	1
18	Perform experiments using circuits containing LEDs and diodes to build phone chargers.	Objective test	-	-	-		2
		Essay	-	1	-	1	2
		Practical test	1	1	1		3
19	Perform experiments using circuits containing LEDs and diodes to build phone chargers.	Objective test	1	3			6
		Essay		1	1		2
		Practical test	-	-		-	1
20	Examine the characteristics, causes, symptoms and preventions of pathogenic diseases	Objective test		1			1
		Essay	-	2	-	-	2
		Test of Practical		1			1
21	Examine specific pathogenic diseases within the community and describe their causes, symptoms and prevention	Objective test		2		1	5
		Essay	-	1	1	-	2
		Test of Practical		1			1

Weeks	Focal Area(s)	Type of Questions	DoK Levels				Total
			1	2	3	4	
22	Explain the science in the production of indigenous beverage	Objective test			1	1	2
		Essay	-	1	-	-	1
		Test of Practical	-	-	-	1	1
23	Design an experiment to produce a local beverage.	Objective test	-	1	-	-	1
		Essay	-	1	1	-	
		Test of Practical	1	1	-	1	4
		Total	15	20	10	5	50

# Bibliography

1. Amoeba Sisters. (2019, March 28). Buoyant force & Archimedes' principle [Video]. YouTube. <https://www.youtube.com/watch?v=AWEdpTOtL6M>
2. Asthma and Allergy Foundation of America. (n.d.). What happens in your airways when you have asthma? Retrieved July 11, 2024, from <https://community.aafa.org/blog/what-happens-in-your-airways-when-you-have-asthma>
3. Bing. (n.d.). Image of [mechanism of inhalation and exhalation]. Retrieved July 10, 2024, from [https://th.bing.com/th/id/OIP.MVo2b8D5CuA\\_8rfo-zZZeQHAEo?rs=1&pid=ImgDetMain](https://th.bing.com/th/id/OIP.MVo2b8D5CuA_8rfo-zZZeQHAEo?rs=1&pid=ImgDetMain)
4. Bing. (n.d.). Image of [structure of the lungs]. Retrieved July 10, 2024, from <https://th.bing.com/th/id/OIP.dcyi3rbMLQi054c-weZLNAAAAA?rs=1&pid=ImgDetMain>
5. Brainly. (n.d.). Structure of the lungs. Brainly. Retrieved July 10, 2024, from <https://brainly.in/question/25692142>
6. Britannica. (n.d.). Lungs help blood cells body Oxygen. In Encyclopædia Britannica Online. Retrieved July 10, 2024, from <https://www.britannica.com/video/72993/Lungs-help-blood-cells-body-Oxygen>
7. Britannica. (n.d.). Respiratory tract. In Encyclopædia Britannica Online. Retrieved July 10, 2024, from <https://www.britannica.com/video/72992/respiratory-tract-lungs-mouth-air-nose-gases>
8. Byju's. (n.d.). \*Floatation - definition and principles\*. Byju's. Retrieved July 10, 2024, from <https://byjus.com/physics/floatation/>
9. Center for Disease Control and Prevention. (2023, June 5). Malaria - Plasmodium Life Cycle [Video]. YouTube. <https://www.youtube.com/watch?v=1v55yg0RfoY>
10. CircuitBread. (2019, August 20). Understanding parallel circuits [Video]. YouTube. [https://www.youtube.com/watch?v=BYK\\_UnmGrko](https://www.youtube.com/watch?v=BYK_UnmGrko)
11. Continental Hospitals. (n.d.). Common symptoms of pneumonia: How can I prevent it? Retrieved July 11, 2024, from <https://continentalhospitals.com/blog/common-symptoms-of-pneumonia-how-can-i-prevent-it/>
12. Discover. (n.d.). The respiratory pathway. HubPages. Retrieved July 10, 2024, from <https://discover.hubpages.com/health/The-Respiratory-Pathway>
13. Electronics Basics. (2017, October 12). Parallel circuits - basics, calculations, and demonstrations [Video]. YouTube. <https://www.youtube.com/watch?v=A2YyIo8vSCA>

14. Elprocus. (2023, July 30). Different types of electronic circuit symbols. Elprocus. Retrieved July 31, 2024, from <https://www.elprocus.com/different-types-of-electronic-circuit-symbols/>
13. GeeksforGeeks. (n.d.). \*Real-life applications of Archimedes' principle\*. GeeksforGeeks. Retrieved July 10, 2024, from <https://www.geeksforgeeks.org/real-life-applications-of-archimedes-principle/>
16. GreenViews Residential. (n.d.). Traditional Ghanaian drinks. GreenViews Residential. Retrieved from <https://greenviewsresidential.com/traditional-ghanaian-drinks/>
17. HHMI BioInteractive. (2015, October 15). The Malaria Lifecycle: Human Stages [Video]. YouTube. <https://www.youtube.com/watch?v=7wFz1z30epM>
18. <https://www.quora.com/How-can-I-build-a-step-down-transformer>
19. Instructables. (n.d.). \*Tin Foil Pop Pop Boat\*. Instructables. Retrieved July 10, 2024, from <https://www.instructables.com/Tin-Foil-Pop-Pop-Boat/>
20. Lawrence, S. (2019, May 29). Upthrust - Explained [Video]. YouTube. <https://www.youtube.com/watch?v=zzmHjgOPORY>
21. Lumen Learning. (n.d.). Kidney function and physiology. Retrieved June 20, 2024, from <https://courses.lumenlearning.com/wmbiology2/chapter/kidney-function-and-physiology/>
22. Lung Cancer Center. (n.d.). What is smoker's lung? Retrieved July 11, 2024, from <https://www.lungcancercenter.com/news/what-is-smoker-lung/>
23. Melbourne Vascular Surgery Centre. (n.d.). Liver Fibrosis. Retrieved July 10, 2024, from <https://mvscentre.com.au/conditions/liver-fibrosis/>
24. Microbe Notes. (n.d.). Lungs: Structure and diseases. Retrieved July 10, 2024, from <https://microbenotes.com/lungs-structure-diseases/>
25. Ministry of Education, Myanmar. (n.d.). Excretory system. University of Medicine, Magway. Retrieved June 20, 2024, from <https://www.ummg.edu.mm/Media/Documents/ExcretorySystem11.pdf>
26. Nature. (2022). Title of the article. Nature, volume(issue), pages. <https://doi.org/10.1038/s41407-022-0859-1>
27. Nicorette. (n.d.). How to help lungs recover after quitting smoking. Retrieved July 11, 2024, from <https://www.nicorette.com/why-quit-smoking/reasons-to-quit/how-to-help-lungs-recover-after-quitting-smoking/>
28. Ounje Aladun. (2021, May 17). Pito - How to make Pito, Asana (non-alcoholic drink). Ounje Aladun. Retrieved from <https://ounjealadun.com/2021/05/17/pito-how-to-make-pito-asana-non-alcoholic-drink/>
29. Pickering W R. (2000) Complete Biology, Oxford University Press

30. Regency Healthcare. (n.d.). Here's how cigarette smoking can affect your lungs. Retrieved July 11, 2024, from <https://regencyhealthcare.in/blog/heres-how-cigarette-smoking-can-affect-your-lungs/>
31. SmartDraw. (n.d.). Electrical and electronic symbols. SmartDraw. Retrieved July 31, 2024, from <https://www.smartdraw.com/circuit-diagram/electrical-symbols.htm>
32. Standring, S. (2016). Gray's Anatomy: The Anatomical Basis of Clinical Practice (41st ed.). Elsevier.
33. Study Mind. (n.d.). Structure of the lungs. StudyMind. Retrieved July 10, 2024, from <https://studymind.co.uk/notes/structure-of-the-lungs/>
34. TED-Ed. (2019, July 12). The law of floatation - Archimedes' principle explained [Video]. YouTube. [https://www.youtube.com/watch?v=L\\_A0c0w0dMs](https://www.youtube.com/watch?v=L_A0c0w0dMs)
35. The Canadian African. (n.d.). Sobolo (Spiced Hibiscus Drink). The Canadian African. Retrieved from <https://thecanadianafrican.com/sobolo-spiced-hibiscus-drink/>
36. Toppr. (n.d.). The given figure shows a model demonstrating the mechanism of breathing. What is incorrect about the... Toppr. Retrieved July 10, 2024, from <https://www.toppr.com/ask/question/the-given-figure-shows-a-model-demonstrating-the-mechanismof-breathing-what-is-incorrect-about-the/>
37. Tortora, G. J., & Derrickson, B. H. (2017). Principles of Anatomy and Physiology (15th ed.). Wiley.
38. Vecteezy. (n.d.). The process of breathing explained [Image]. Vecteezy. Retrieved July 10, 2024, from [https://static.vecteezy.com/system/resources/previews/001/879/203/non\\_2x/the-process-of-breathing-explained-free-vector.jpg](https://static.vecteezy.com/system/resources/previews/001/879/203/non_2x/the-process-of-breathing-explained-free-vector.jpg)
39. Yaclass. (n.d.). Breathing and gas exchange. Yaclass. Retrieved July 10, 2024, from <https://www.yaclass.in/p/science-cbse/class-7/respiration-in-organisms-23336/breathing-and-gas-exchange-8451/re-f1ff2811-dd4b-4ecf-b3b9-809069d70580>

